

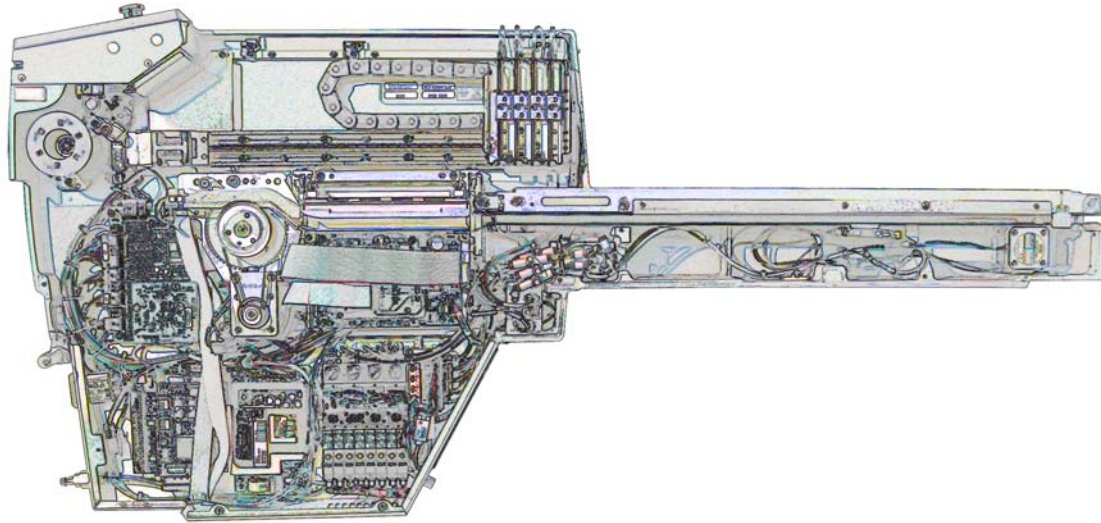

## Service



For installation, operation, maintenance, and troubleshooting, see the ProLINE-RoadRunner Owner's Manual

# ProLINE-RoadRunner™ Service Manual for

- SIPLACE X
- MYDATA
- PANASONIC NPM



PN 096-0262-001B

Data I/O has endeavored to ensure that the information in this document is accurate and complete. Data I/O assumes no liability for errors, or for any incidental, consequential, indirect, or special damages, including, without limitation, loss of use, loss or alteration of data, delays, or lost profits or savings, arising from the use of this document or the product which it accompanies.

No part of this document may be reproduced or transmitted in any form or by any means, electronic or mechanical, for any purpose, without written permission from Data I/O Corporation. Data I/O order forms may be reproduced for immediate customer use only.

Data I/O, TaskLink and ProLINE-RoadRunner are trademarks of Data I/O Corporation.

Data I/O Corporation acknowledges the trademarks of other organizations for their respective products or services mentioned in this document.

Data I/O Corporation also acknowledges the RoadRunner team members for supporting the flow of information into this manual.

We are interested in your comments. Please e-mail: [userdocs@dataio.com](mailto:userdocs@dataio.com)

© 2010-2011 Data I/O Corporation  
All rights reserved

---

# Table of Contents



**096-0262-001B**

For non-service information see the Owner's Manual, 096-0240.

Precautions for Safe Operation	iii
RoadRunner Models Covered	M-1
Replaceable Modules	M-3
Components Overview	M-4
Component List	M-5
SMT to RoadRunner Adapters	M-6
Covers	M-8
Removing the Robotics Cover	M-9
Removing the Lower Cover	M-9
Removing the Conveyor Module Cover	M-10
Tape-In Module	M-12
Removing the Adjustable Tape-In Module	M-13
Pneumatic Module	M-16
Replacing the Vacuum Filters	M-17
Removing the Pneumatic Module	M-18
Reinstalling the Pneumatic Module	M-21
Adjusting the Low Air Pressure Sensor	M-21
Cover Tape Module	M-24
Removing the Cover Tape Module	M-25
Conveyor Module	M-26
Removing the Conveyor Module	M-27
Adjusting the End-of-Belt Sensor	M-28
Reject Bin	M-32
Removing the Reject Bin Sensors	M-33
Control Panel Module	M-34
Removing the Control Panel Module	M-35

---

## Pick and Place Head M-37

- Aligning Pick and Place Points M-37
- Adjusting and Balancing Probe Speed M-37
- Adjusting Probe Raising Speed M-39
- Resetting the Pick Delay and Travel Delay Times M-41
- Adjusting Probe Vacuum Sensors M-42
- Removing the PNP Head M-44

## Programmer Module M-46

- Removing the Programmer Module M-47

## NVRAM Battery M-54

- Removing the NVRAM Battery M-55
- Installing a new NVRAM Battery M-57
- Reinstalling Components M-57
- Reteaching the NVRAM M-58

## Linear Stage Module M-60

- Removing the Linear Stage Module M-61

## Spares Kits M-63

### Basic Spares Kit, Standard RoadRunner M-64

- Replacing the Probe Tips M-65
- Replacing the Air Inlet Tube Assembly M-65

### Self-Service Spares Kit, Standard RoadRunner M-66

### Basic Spares Kit, Large Format RoadRunner M-68

- Replacing the Probe Tips M-69
- Replacing the Air Inlet Tube Assembly M-69

### Self-Service Spares Kit, Large Format RoadRunner M-70

### Socket Adapter, Actuator, and Precisor M-72

## Alphabetical Index Index-1

## Precautions for Safe Operation

The RoadRunner System has been designed for safe and efficient operation. **The system can be dangerous if the RoadRunner safety features and precautions in this manual are ignored.**

To avoid possible personal injury or damage to the equipment, please observe the following practices:

- Only **trained personnel** should install, maintain, repair, or troubleshoot this system.
- Do not operate the ProLINE-RoadRunner unless you have been thoroughly trained, and have **read and understand the instructions** in this manual, particularly those that describe the system's safety features.
- Do not use ProLINE-RoadRunner for any application other than its **intended use**.
- Do not operate the system if the **guards or safety devices** are not in their normal operating positions.
- Do not operate RoadRunner with any of the **outer sheet metal panels** removed.
- Do not operate RoadRunner while servicing, replacing, or adjusting any component unless directed to do so in this manual. Make sure that the RoadRunner is **properly shut down** before performing any of these operations.
- Do not place any part of your body near or in the direct path of **moving parts**.
- **Do not disable** or attempt to defeat any of the protective safety features of this system. Personal injury or equipment damage can occur if any safety systems on RoadRunner are disabled. If you suspect that a safety feature of the RoadRunner is damaged or malfunctioning, stop using the RoadRunner immediately and contact Data I/O Customer Service or a local Data I/O approved service representative.
- Use extra caution when working around the RoadRunner's Output Belt. RoadRunner's safety shields do not cover or fully enclose the **output conveyor**. It is possible that an operator's hands, other body parts, or loose clothing can get caught or pinched in it.
- Wearing **hearing protection** is recommended while operating the RoadRunner. Sound pressure levels may exceed 85 decibels.
- Shut off the **pressurized air** or disconnect the air hose before servicing pneumatic parts.



### Electrostatic Discharge

The circuit boards inside RoadRunner are susceptible to electrostatic discharge (ESD), which can damage the circuitry. Also, devices processed through the RoadRunner are very sensitive to static and can be damaged by accidental electrostatic discharge while being handled.

The easiest way to prevent damage from ESD is to make sure a common static potential (**ground**) exists between static-sensitive devices or components, their environment, and the operator.

Perform all repairs at an ESD-safe workstation.

Blank page.



# Service—M10

---

This model of Data I/O's ProLINE-RoadRunner supports many assembly machines, programming and delivering microchips from the feeder bank.

This service chapter covers only the models listed below.

## RoadRunner Models Covered

This manual covers three Standard models of RoadRunner which support these SMT Placement machines:

- RoadRunner/**SIPLACE X**: X2, X3, X4 and X4i
- RoadRunner/**MYDATA**: MY9, MY12, MY15, and MY19
- RoadRunner/**PANASONIC**: NPM

---

*NOTE: This manual does not cover service instruction for XLF (eXtra Large Format) RoadRunners. If there is an XLF RoadRunner\* for your assembly machine, it has a separate manual.*

*\* Runs devices up to 32 mm Wide x 32 mm Long x 6 mm High.*

---

Many modules and components on the RoadRunner are designed for easy service or replacement by qualified technicians. You may wish to keep backup modules or components for replacements. The replaced module or component may be sent to Data I/O for repair or adjustment.

---

*NOTE: Send RoadRunners under warranty back to Data I/O.*

*If your RoadRunner is NOT under warranty, you have the option of repairing it with instructions in this manual or sending it back to Data I/O. See the inside back cover for contact information.*

---

M10

M10



## Replaceable Modules

Replaceable modules include:

- Tape-In Module
- Conveyor Module
- Control Panel Module
- Linear Stage Module (with PNP Head)
- Pneumatic Module
- Cover Tape Module
- PNP Head (subassembly)
- Programmer Module

Some components can be replaced or adjusted at the customer location. Replacement and adjustment procedures for those components are included in this chapter. Some modules can be removed and sent to Data I/O or a local representative for servicing or exchanging.

**Within each main section of this chapter is an order form with relevant Sales Part Numbers. These names represent the RoadRunner configuration at the time of printing this manual only, and may not be the same as your unit.** However, the Sales Part Numbers usually correspond to the latest interchangeable replacement.



*Tools required for RoadRunner maintenance are listed in the Owner's Manual under "Tools Required" on page 5-1.*

Some of the tools required are • Metric hex keys (Allen wrenches), • a volt meter or multi-meter, • a metric scale or calipers, • a flat blade screw driver, • and a Phillips screw driver.



**CAUTION:** *Electrostatic discharge may damage parts. Before servicing, place the RoadRunner on an ESD-safe workstation.*

# Components Overview

M10

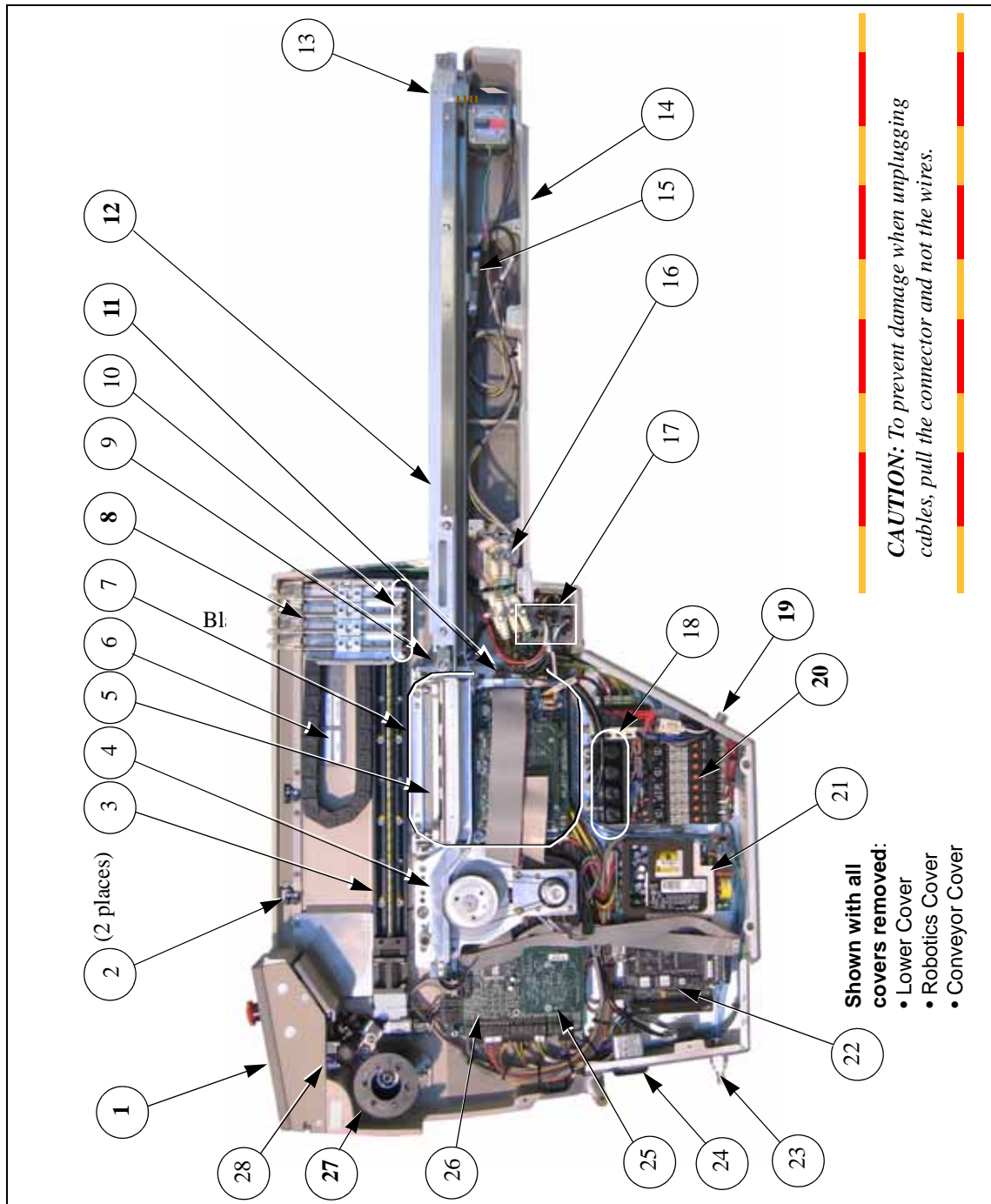

Figure 1—Component Overview. SMT Adapter not shown.



**CAUTION:** Electrostatic discharge may damage parts. Before repair work begins, place the RoadRunner on an ESD-safe workstation.

M10

## Component List



Modules are listed in bold type. (Modules are assemblies installed/replaced as a unit.)

1. **Control Panel Module**, [page M-34](#)
2. Head Limit Cable (2 sensors)
3. Linear Stage
4. **Tape-In Module**, [page M-12](#)
5. Socket Adapter
6. Serial Number Label
7. **Programmer Module**, [page M-46](#)
8. Pick and Place (PNP) Head
9. Reject Bin
10. Rubber Probe Tips
11. Socket Actuator Sensor
12. **Conveyor Module**, [page M-26](#)
13. End-Of-Belt Sensor Optic
14. “Nose”
15. End-Of-Belt Optical Fiber Amplifier
16. Probe Control Manifold
17. Interconnect Panel
18. Vacuum Filters
19. Communication connection
20. **Pneumatic Module**, [page M-16](#)
21. Power Supply
22. Motion Controller PCB
23. Air inlet connection
24. Power Switch
25. SMT Communications PCB
26. Robot I/O PCB
27. **Cover Tape Module**, [page M-24](#)
28. Robotics-Cover-Open Sensor



**CAUTION:** Electrostatic discharge may damage parts. Before repair work begins, place the RoadRunner on an ESD-safe workstation.

## SMT to RoadRunner Adapters

Some RoadRunner models use hardware to adapt to specific Surface Mount Technology feeder tables and carts. In most cases, the SMT Adapter also facilitates the communication connection between the SMT and RoadRunner. Mounting procedures, supplied assemblies and responsibilities vary with each model, therefore attention to these details is important.



**CAUTION:** Feeder carts can become unstable. The RoadRunner can also be mounted on feeder carts and feeder test stands. However, some carts/stands were not designed for the heavy overhang of the RoadRunner and can tip over easily, especially if the wheels encounter bumps. Use caution; don't use (and do label) unsafe carts.

M10

Adapter for Siemens SIPLACE X Machine; mounts to RoadRunner before mounting onto SMT machine.



Adapter for MYDATA SMT Machine; mounts to the feeder table separately.



Adapter for PANASONIC NPM SMT Machine. The Host Feeder Communication attachment is shown in dashed lines.

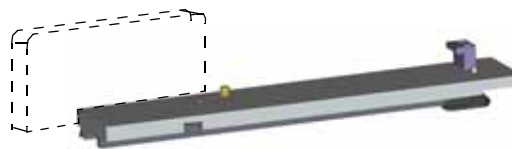

M10

M10

Blank page

M10

# Covers

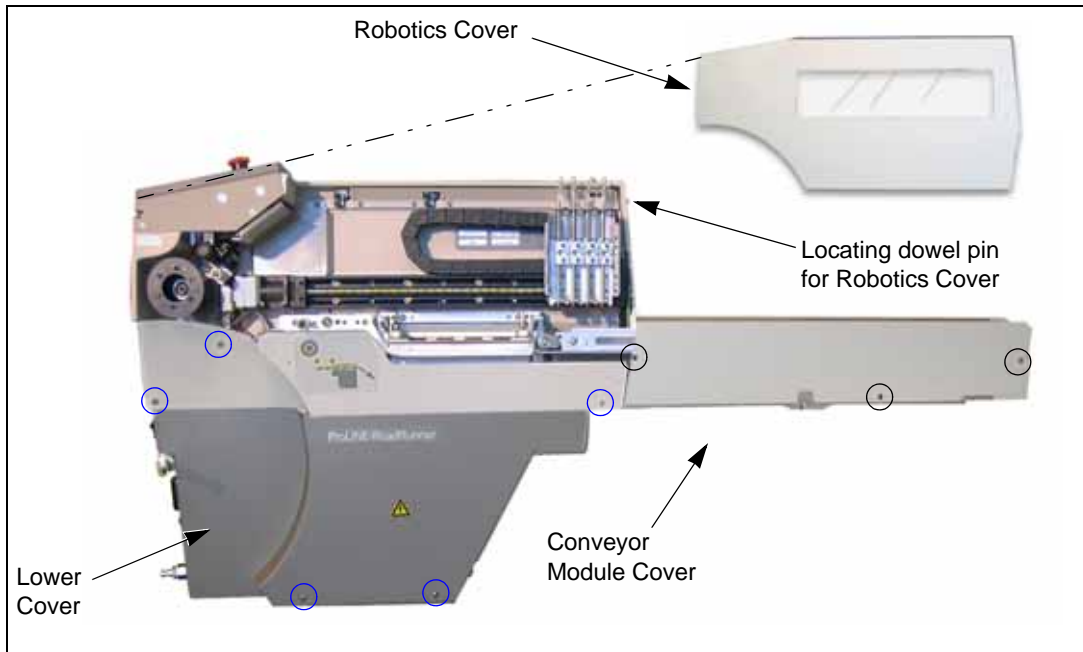

Figure 2—Covers (with Screw Locations Indicated by Circles)

The RoadRunner has three removable covers:

- Robotics Cover
- Lower Cover
- Conveyor Module Cover

The Robotics Cover shields the tape path and the programmer.

## Data I/O Parts Ordering Information

**Instructions:** 1. Copy this page. 2. Fill in your RoadRunner model and serial numbers (see the label on the chassis under the Robotics Cover). 3. Fill in the quantity for the item(s) desired. 4. (Optional) Call your local Data I/O sale representative for part prices or use our Web page for Requesting Quotes. 5. E-mail to OrderAdmin@dataio.com or FAX to 425-867-6972 with your purchase order.

ProLINE-RoadRunner Model No. \_\_\_\_\_ Serial No. \_\_\_\_\_

Sales Part Number	Part Description	Qty	Price Ea.	Totals
RR-ROBOTICS COVER - F,U,A	Robotics Cover		\$	\$
RR-LOWER COVER	Lower Cover		\$	\$
RR-COVER CONVEYOR-U OR A	Conveyor Module Cover		\$	\$

Signature: \_\_\_\_\_ Date: \_\_\_\_\_ Company: \_\_\_\_\_

M10

M10

## Removing the Robotics Cover

Grasp the outer edges of the Robotics Cover and gently pull away from the Control Panel and out.

There is a locating dowel pin on the end opposite the Control Panel Module.

*NOTE: The Robotics Cover can be removed while the RoadRunner is running. However, the robot speed reduces by 50%.*

### ! WARNING

*Shock Warning. Do not remove the Lower Cover while the RoadRunner is plugged in.*

## Removing the Lower Cover

1. Turn the power off.
2. Disconnect the RoadRunner power cord and air supply.

*NOTE: The RoadRunner pressurized air supply tube has a quick disconnect fitting, called a one-touch fitting, with an automatic shut off. The line may be disconnected without shutting off the supply line air pressure.*



For screw locations see [Figure 2](#).

For a detail of the cover clip see [Figure 3](#).

3. Lift off the Robotics Cover.
4. Remove the five screws that hold the Lower Cover to the chassis.
5. Slide the cover up (toward the Control Panel) to unhook a clip in the lower left corner, then lift off.

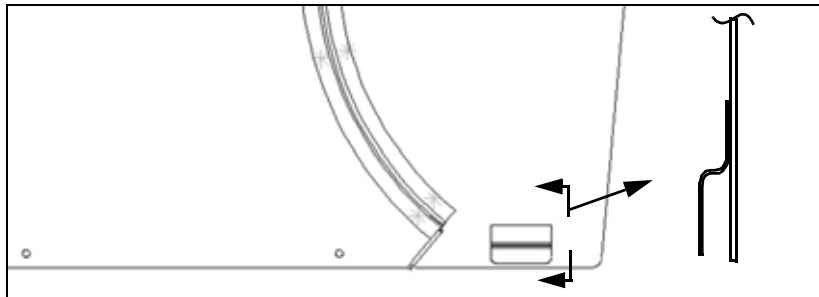

Figure 3—Detail of Clip: View looking at the Inside of the Lower Cover

## Removing the Conveyor Module Cover



For screw locations see  
*Figure 2.*

Remove the three screws that hold the Conveyor Module Cover to the chassis.

### **WARNING**



***Possible electric shock hazard. Ensure that the power is Off before removing or installing covers. Use extreme caution any time this manual instructs you to turn the power On while a cover is off.***



Blank page

M10

M10

# Tape-In Module

Remove the Position Locking Screw to remove the Tape-In Module body, after which the two Base Mounting Screws are accessible.

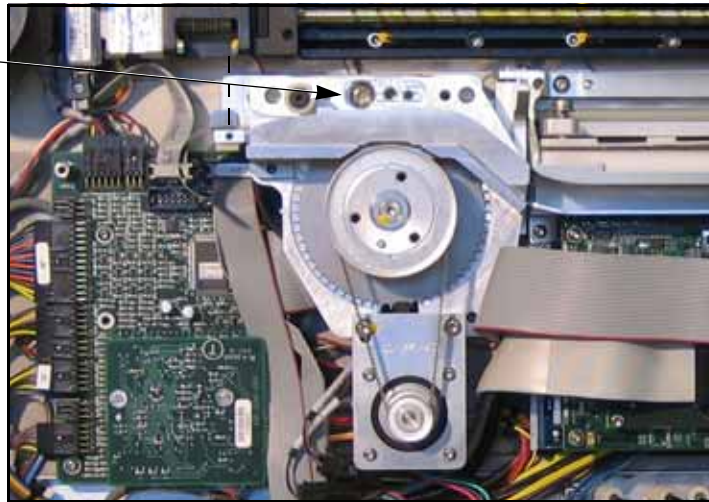

Figure 4—Adjustable Tape-In Module shown. Location of the Position Locking Screw. (Base Mounting Screws are Hidden.)

The Tape-In Module advances the device tape. The Tape-Advance Sensor senses sprocket motion while a second sensor determines if cover tape is broken.

If the device tape is not advancing correctly, there could be a problem with the Tape-In Module. Refer to the Troubleshooting chapter of the RoadRunner Owner’s manual to identify the problem. If the problem is the Tape-In Module, remove it and return it to Data I/O for repair or replacement. If your RoadRunner is past warranty period, you may elect to repair it on-site if you have a certified technician.

Two sensors on the far side of this module can be replaced independently.

## Data I/O Parts Ordering Information

**Instructions:** 1. Copy this page. 2. Fill in your RoadRunner model and serial numbers (see the label on the chassis under the Robotics Cover). 3. Fill in the quantity for the item(s) desired. 4. (Optional) Call your local Data I/O sale representative for part prices or use our Web page for Requesting Quotes. 5. E-mail to OrderAdmin@dataio.com or FAX to 425-867-6972 with your purchase order.

ProLINE-RoadRunner Model No. \_\_\_\_\_ Serial No. \_\_\_\_\_

Sales Part Number	Part Description	Qty	Price Ea.	Totals
RR-TAPE IN,12MM	Tape-In Module, 12mm		\$	\$
RR-TAPE IN,16MM	Tape-In Module, 16mm		\$	\$
RR-TAPE IN,24MM	Tape-In Module, 24mm		\$	\$
RR-TAPE IN,32MM	Tape-In Module, 32mm		\$	\$
7502296001	Tape In, Adjustable		\$	\$
RR-SLOT SENSOR CAB	Tape Advance Sensor (Cable Assy)		\$	\$
RR-SLOT SENSOR CAB	Cover Tape Broken Sensor (Cable Assy)		\$	\$
			\$	\$

Signature: \_\_\_\_\_ Date: \_\_\_\_\_ Company: \_\_\_\_\_

## Removing the Adjustable Tape-In Module

*NOTE: The **Standard** Tape-In Module does not apply to the RoadRunner models covered in this Service Manual.*

1. Turn the power off.
2. Disconnect the RoadRunner power cord and air supply.
3. Remove the Robotics Cover and Lower Cover.
4. Remove the two screws attaching the Tape Guide to the Adjustable Tape-In (ATI) Module (required only if exchanging the module—you will reuse this same guide).

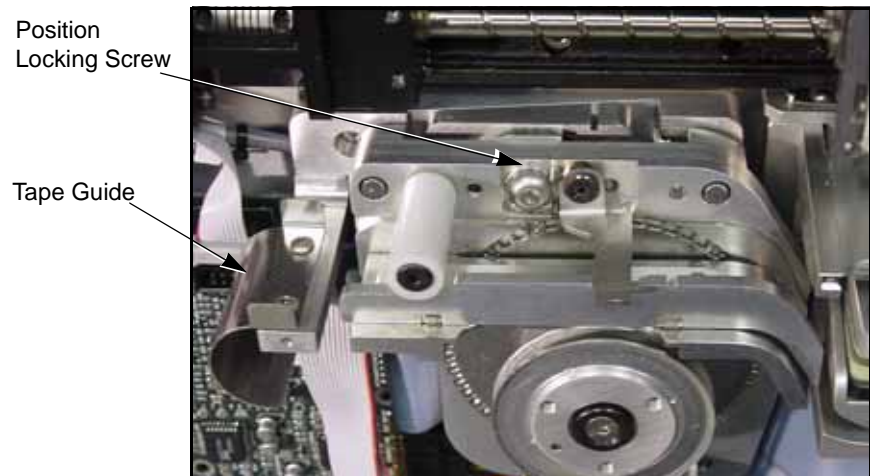

Figure 5—The Adjustable Tape-In Module with Tape Guide noted.

5. Unscrew the Position Locking Screw with a 4 mm hex key and lift the subassembly away from the Base as far as the wires allow.
6. Check that wire labels are clearly marked and unplug the wires for the Tape Advance Sensor, the Cover Tape Broken Sensor, and the Tape-In Motor.

*NOTE: The two sensors are the same—where they plug in determines their function.*

*The sensors may be replaced independently of the module.*

7. Remove the three screws that attach the ATI Base to the chassis. See the figure below.



Figure 6—Adjustable Tape-In Module Base

8. Lift the Base from the chassis.

Replacement is in the reverse order of removal with these precautions:

- Ensure that cable connectors are mated correctly.
- Ensure that no wires or hoses get pinched. Check ribbon cables carefully.
- If you are installing a Tape-In Module other than the one you removed, you need to align it to the PNP Head by performing the alignment procedure. (See next heading.)

### ***Aligning the Adjustable Tape-In Module***

To center the tape path under the PNP probes:

1. Load a piece of empty device tape into the Adjustable Tape-In (ATI) Module or install the Tape-In Alignment Tool (PN 6157047001).
2. Move the PNP Head so that Probe 1 is directly over the pick point.
3. Remove the precisor.
4. Remove the rubber probe tip from Probe 1.
5. Remove the vacuum chamber block (metal torus on probe).
6. Extend Probe 1 fully (by pushing down on the top of the air cylinder shaft) to visually compare the position of the hole in the center of the tape pocket to the probe.

If the probe is centered over the hole, then the tape path is centered. Replace the probe tip, vacuum chamber, and precisor; you are done centering the tape path. Otherwise continue.

7. Loosen the Position Locking Screw with a 4 mm hex key.



*There may be an optional method using a Tape-In Alignment Jig. Contact Data I/O support for more information.*

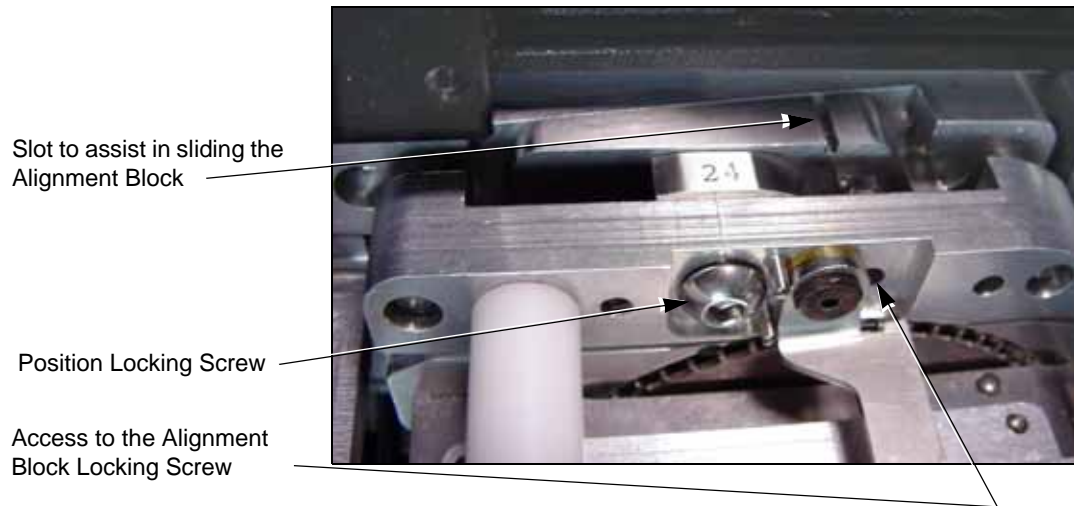

Figure 7—Aligning the Adjustable Tape-In Module

8. Loosen the Alignment Block Locking Screw with a 2 mm hex key. A small access hole is provided.
9. Slide the Alignment Block left (to move the tape out) or right (to move the tape in) as needed to bring the device tape in-line with the probe. A slot in the top of the Alignment Block accommodates a slotted screwdriver to assist in sliding the block.
10. Tighten the Position Locking Screw.
11. Recheck alignment.
12. Tighten the Alignment Block Locking Screw.
13. Reinstall the vacuum chamber.
14. Reinstall the precisor.
15. Reinstall the Probe Tip.

# Pneumatic Module

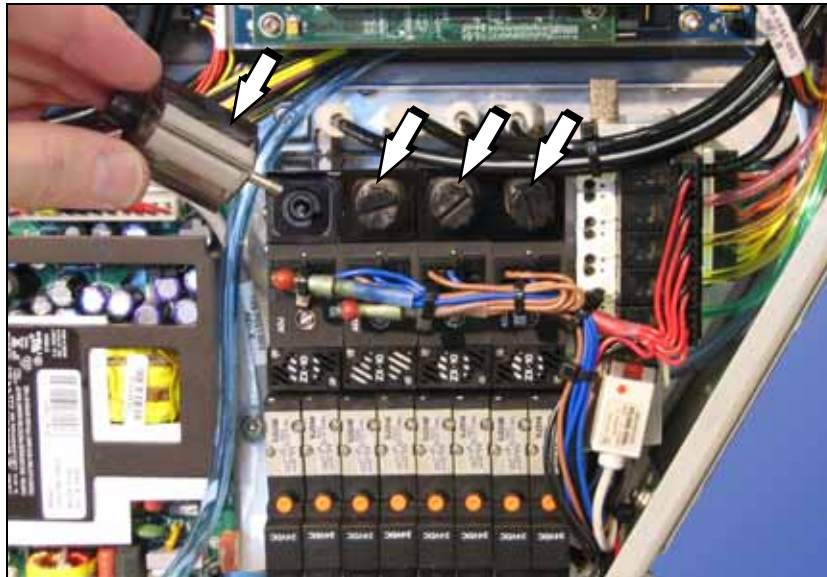

Figure 8—Pneumatic Module and four Vacuum Filter locations.

The Pneumatic Module controls vacuum and blow-off air to the probes, as well as pressurized air to the probe cylinders and programmer socket cylinders.

Pneumatic Module suction is affected by clogged or dirty filters or hoses and by improper connections. If the vacuum filters are clogged or dirty, vacuum sensors have difficulty detecting whether a device is on the probe or not. This can result in error messages such as “Device pick failure at input with probe 1.”

## Data I/O Parts Ordering Information

**Instructions:** 1. Copy this page. 2. Fill in your RoadRunner model and serial numbers (see the label on the chassis under the Robotics Cover). 3. Fill in the quantity for the item(s) desired. 4. (Optional) Call your local Data I/O sale representative for part prices or use our Web page for Requesting Quotes. 5. E-mail to OrderAdmin@dataio.com or FAX to 425-867-6972 with your purchase order.

ProLINE-RoadRunner Model No. \_\_\_\_\_ Serial No. \_\_\_\_\_

Sales Part Number	Part Description	Qty	Price Ea.	Totals
RR-VAC FILTER	Vacuum filter		\$	\$
ASSY,PNEUMATIC,MODULE	Pneumatic Module		\$	\$
			\$	\$
			\$	\$
			\$	\$

Signature: \_\_\_\_\_ Date: \_\_\_\_\_ Company: \_\_\_\_\_

If you experience problems such as dropped devices or pick failures, replace the vacuum filters (below), adjust the vacuum sensor (page M-42), or see the chapter on “Troubleshooting.”

---

*NOTE: In normal low-dust conditions, Vacuum Filters must be replaced every six months. Replacement may need to be done more frequently in dustier environments.*

---

## Replacing the Vacuum Filters



For more information, see  
“Covers” on page M-8.

1. Turn the power off.
2. Disconnect the RoadRunner power cord and air supply.
3. Remove the Robotics and Lower Covers.
4. Remove the square plastic housings with the Vacuum Filters by unscrewing the thumbscrews from the valve block.

---

*NOTE: Ensure that the gasket between the housing and the valve block does not fall out during removal or installation of the housing. If it does, install the gasket into the groove on the valve block.*

---

---

**CAUTION:** The housing has two locating pins. To prevent damage, orient the housing correctly when reinstalling.

---

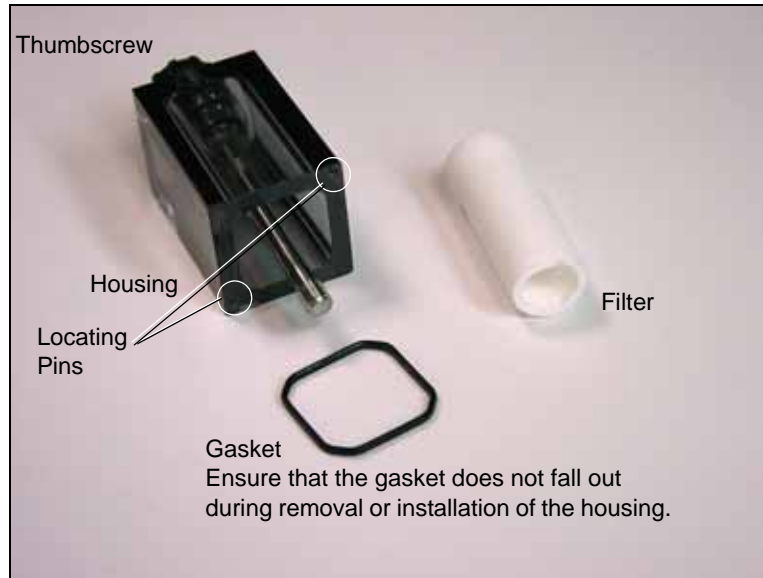

Figure 9—Vacuum Filter Components

5. Remove the filter from the plastic housing.
6. When installing a new filter, make sure the rubber gasket is in place between the housing and the valve block.

## Removing the Pneumatic Module



The RoadRunner pressurized air supply tube has a quick disconnect fitting with an automatic shut off. The line may be disconnected without shutting off the supply line air pressure.



For more information, see “Removing the Lower Cover” on page M-9.



For the location of Probe vacuum lines see Figure 11.

1. Turn the power off.
2. Disconnect the RoadRunner power cord and air supply.
3. Pull off the Robotics Cover.
4. Remove the Lower Cover(s).

*NOTE: The vacuum lines and air pressure lines must be reinstalled to their same locations. Do not reverse them. Ensure that each line has a label before disconnecting.*

5. Disconnect the four vacuum lines on the manifold adjacent to the filters. To release the “One-touch” connector, push the connector sleeve and pull the tube simultaneously. See figure below. (To reconnect, simply insert the tube into the housing sleeve, pushing it all the way in.)



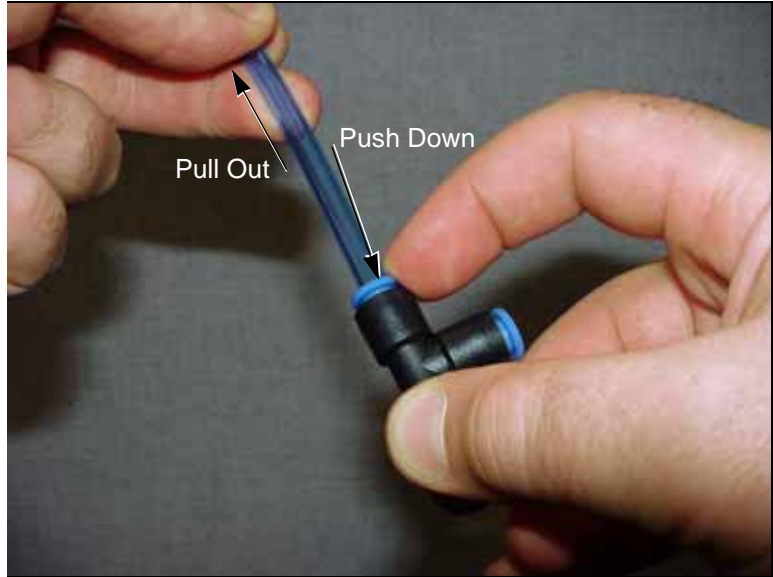

Figure 10—Disconnecting a Pneumatic Tube from the One-touch Connector

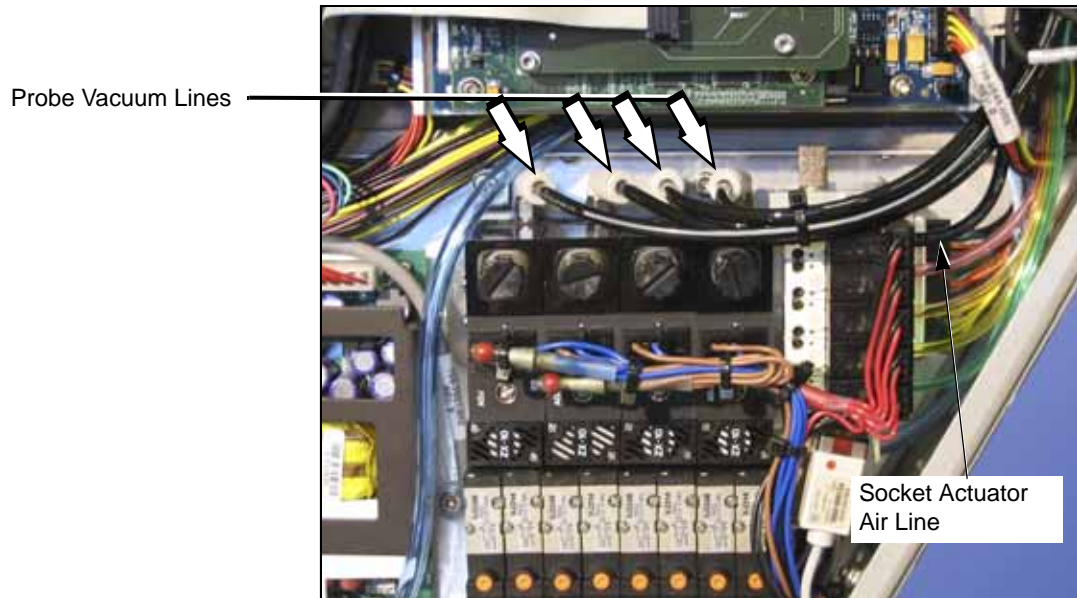

Figure 11—Location of Vacuum and Air Lines

M10

M10



The pneumatic access cover, secured with two screws, is on the back housing flange. See [Figure 12](#).

6. Remove the Pneumatic Access Cover.
7. Disconnect the Pneumatic Manifold Supply Line at the One-touch connector on the manifold.
8. Unscrew the two screws from the 25-pin cable connector and unplug the connector from the manifold bracket.



Figure 12—Location of the Pneumatic Manifold Supply Line and Wiring Connector

9. Remove the three screws securing the Pneumatic Module to the RoadRunner chassis. See figure below.

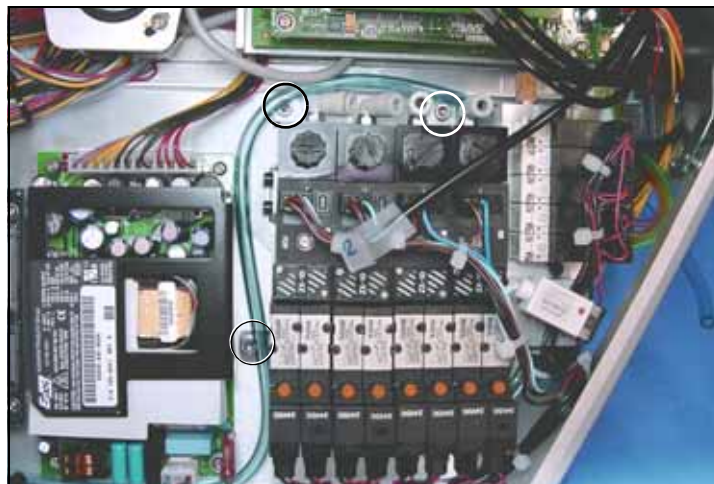

Figure 13—Pneumatic Module fastener locations. The Probe Vacuum Tubes have been disconnected.



To identify tubing lines see [Figure 11](#) and [Figure 12](#).

10. Lift the Pneumatic Module enough to remove the four Probe Air Tubes and the Socket Actuator Air Tube (one-touch fittings).

M10

M10

11. Lift the Pneumatic Module free from the RoadRunner chassis.

## Reinstalling the Pneumatic Module

Installation is done in the reverse order of removal; then the following post-installation adjustments are required:

1. Reconnect the power and pressurized air.
2. Switch the power on and verify that a Supervisor card is in the RoadRunner.
3. At the Control Panel, verify proper electrical and pneumatic connections as follows:
  - 3a. Extend and retract each probe to verify correct plumbing. *Robot Diagnostics » Probe X » Position » Arrow Up/Down.*
  - 3b. Enable vacuum to each probe to verify correct plumbing. *Robot Diagnostics » Probe X » Vac Sense » Arrow Up/Down.*
  - 3c. Enable probe “Puff” and verify correct switching of positive air pressure at the probe tips. *Robot Diagnostics » Probe 1 » Puff » Up/Down Arrow.*
  - 3d. Check the operation of the Socket Actuator. *Robot Diagnostics » Socket » State » Up/Down Arrow.*
4. Adjust the probe vacuum sensors.
5. Adjust probe speed.



For step 4 see “Adjusting Probe Vacuum Sensors” on page M-42.

For step 5 see “Adjusting and Balancing Probe Speed” on page M-37.

## Adjusting the Low Air Pressure Sensor



Chapter 6 of the Owner’s Manual has a Troubleshooting Chart that can direct you to adjustment procedures for specific problems.

The Low Air Pressure Sensor is part of the Pneumatic Module and is set at the factory to stop the robot if the incoming air pressure drops below 4.48 Bars (65 psi). If you are experiencing air pressure problems (for example, sockets don’t open), this sensor can be adjusted as follows.

To adjust the Low Air Pressure Sensor:

1. Pause the RoadRunner
2. When the blue lamp is lit, turn the power off.
3. Disconnect the RoadRunner power cord and air supply.
4. Remove the Lower Cover.

**! WARNING**

*Electric shock hazard. The following procedures require the Electronics Cover(s) to be removed while power is on. Only touch items described in the procedures. Use caution.*

5. Reconnect the RoadRunner power cord and air supply.
6. Turn the power on.
7. With the power and the air on, check that the Low Air Pressure Sensor LED is lit.
8. Reduce the inlet air pressure to 4.48 Bar (65 psi) at the external pneumatic filter/regulator.
9. With a small screwdriver, rotate the sensor adjustment screw counter-clockwise until the LED goes out. Then turn it clockwise just until the LED lights.



*Figure 14—Adjusting the Low Pressure Sensor on the Pneumatic Module. The arrow points to the adjustment screw. The LED is circled.*

10. When the blue lamp is on, turn the power off.
11. Disconnect the RoadRunner power cord and air supply.
12. Replace the Lower Cover.
13. Reconnect the RoadRunner power cord and air supply.
14. Turn the power on.

blank page

M10

M10

# Cover Tape Module



Figure 15—Cover Tape Rollers: Tensioning Roller and Tape-Broken Roller.

If the Cover Tape Module fails to wind tape onto the reel, first check to see if the reel is full. Also, check that there is tension against the Tape-Broken Roller.

If the Take-Up Reel is not full but the module is not winding tape, then the Cover Tape Module is suspect. Check for these:

- loose take-up reel not seated on the pins
- loose or broken drive belt
- malfunctioning motor
- malfunctioning clutch assembly
- a motor connector that is loose or disconnected
- the tape tension roller does not roll freely

If the problem is the motor, clutch assembly, or drive belt, then the Cover Tape Module needs to be replaced. The module can be returned to Data I/O for repair. If your RoadRunner is past warranty period, you may elect to repair it on-site if you have a certified technician.

## Data I/O Parts Ordering Information

**Instructions:** 1. Copy this page. 2. Fill in your RoadRunner model and serial numbers (see the label on the chassis under the Robotics Cover). 3. Fill in the quantity for the item(s) desired. 4. (Optional) Call your local Data I/O sale representative for part prices or use our Web page for Requesting Quotes. 5. E-mail to OrderAdmin@dataio.com or FAX to 425-867-6972 with your purchase order.

ProLINE-RoadRunner Model No. \_\_\_\_\_ Serial No. \_\_\_\_\_

Sales Part Number	Part Description	Qty	Price Ea.	Totals
RR-COVER TAPE MOD	Cover Tape Module		\$	\$
			\$	\$
			\$	\$
			\$	\$

Signature: \_\_\_\_\_ Date: \_\_\_\_\_ Company: \_\_\_\_\_

M10

M10

## Removing the Cover Tape Module

1. Turn the power off.
2. Unplug the RoadRunner power cord.
3. Remove the Robotics Cover.
4. Remove the Take-Up reel from the Cover Tape Module.
5. Remove the three screws that mount the Cover Tape Module to the RoadRunner chassis.

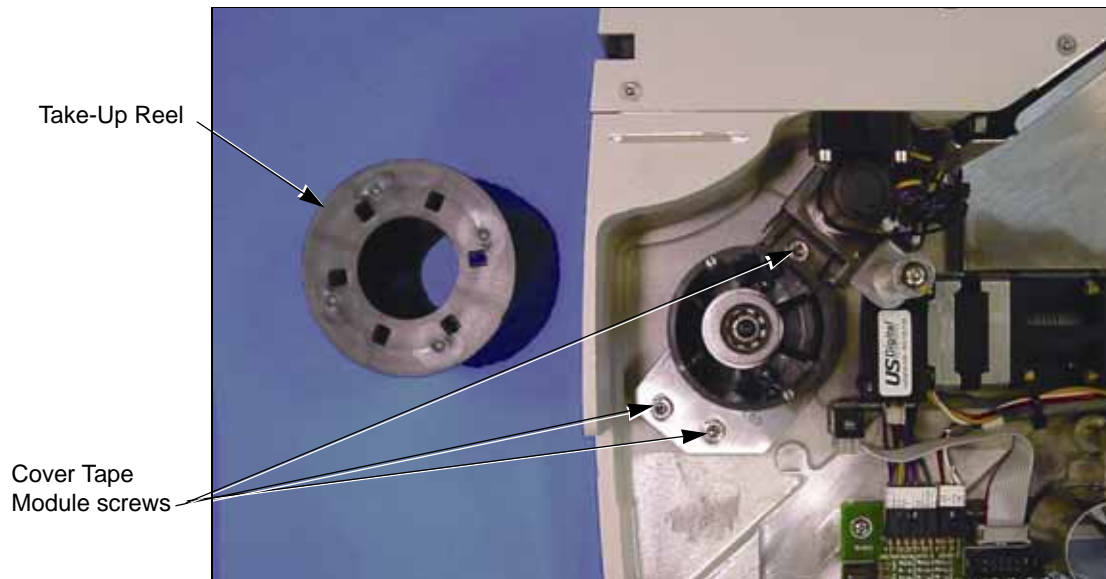

*Figure 16—Location of the Cover Tape Module Mounting Screws (with the Reel Removed)*

6. Disconnect the cable from the Cover Tape Module motor by pinching the clasp and pulling the connector apart.

Replacement of the Cover Tape Module is done in reverse order of removal.

---

*NOTE: There are two styles of Take-Up Reel. One has six holes (shown) and snaps onto the hub; the other has two slots that you fit over pins on the hub and twist into place. Use only the Take-Up Reel appropriate for your hub.*

---

# Conveyor Module

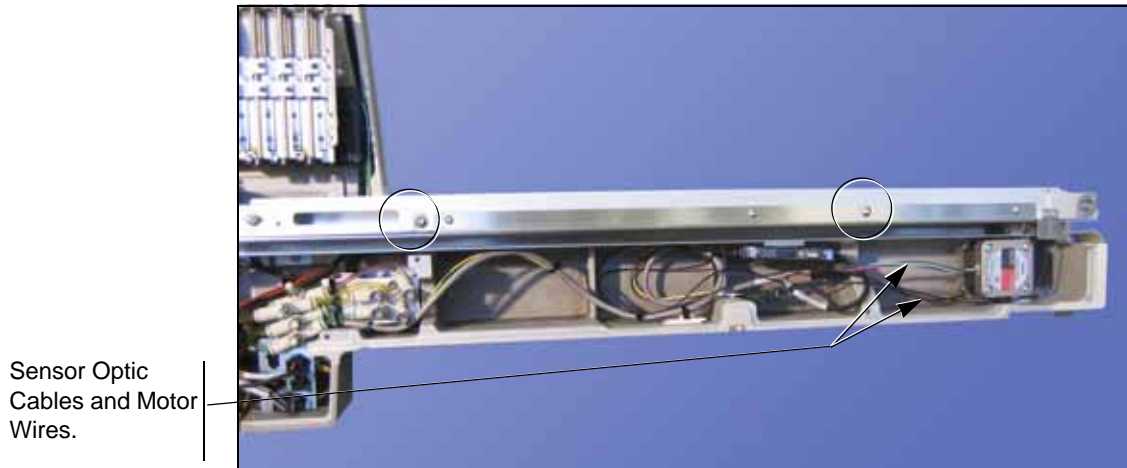

*Figure 17—Location of the Mounting Screws (circled) on the Conveyor Module. Some models have SMT Adapters attached to the chassis nose. It does not need to be removed to remove the Conveyor Module.*

The conveyor belt, the belt motor, and the End-of-Belt Sensor make up the main parts of the Conveyor Module.

If the conveyor belt becomes creased, it will cause devices placed on the crease to be mispositioned. For this reason, a Conveyor Module with a creased or damaged belt should be immediately replaced. However, a belt can become set in the shape it was left in after several days of inactivity. This can be easily remedied by running the RoadRunner in Dry Run mode for two minutes (Robot Diagnostics > Run Mode > Dry Run).

The entire Conveyor Module can be removed and replaced or sent to Data I/O for repair. The End-of-Belt sensor optic can be adjusted and the Optical fiber Amplifier retightened.

## Data I/O Parts Ordering Information

**Instructions:** 1. Copy this page. 2. Fill in your RoadRunner model and serial numbers (see the label on the chassis under the Robotics Cover). 3. Fill in the quantity for the item(s) desired. 4. (Optional) Call your local Data I/O sales representative for part prices or use our Web page for Requesting Quotes. 5. E-mail to OrderAdmin@dataio.com or FAX to 425-867-6972 with your purchase order.

ProLINE-RoadRunner Model No. \_\_\_\_\_ Serial No. \_\_\_\_\_

Sales Part Number	Part Description	Qty	Price Ea.	Totals
7502417001	Conveyor Module, SIPLACE X		\$	\$
7502418001	Conveyor Module, MYDATA		\$	\$
7502331001	Conveyor Module, PANASONIC		\$	\$
			\$	\$

Signature: \_\_\_\_\_ Date: \_\_\_\_\_ Company: \_\_\_\_\_

M10

M10



## Removing the Conveyor Module



For more information, see “Removing the Conveyor Module Cover” on page M-10.

1. Turn the power off.
2. Disconnect the RoadRunner power cord and air supply.
3. Lift off the Robotics Cover.
4. Remove the Conveyor Module Cover.
5. Cut the cable ties securing the wires for the belt motor and sensors.

**CAUTION:** Optic cables are fragile and may break. Use care to bend only gradually and gently, not severely.

6. Disconnect two connectors: belt motor wires and optical fiber amplifier wires by pinching the clasp open and pulling the connector apart.

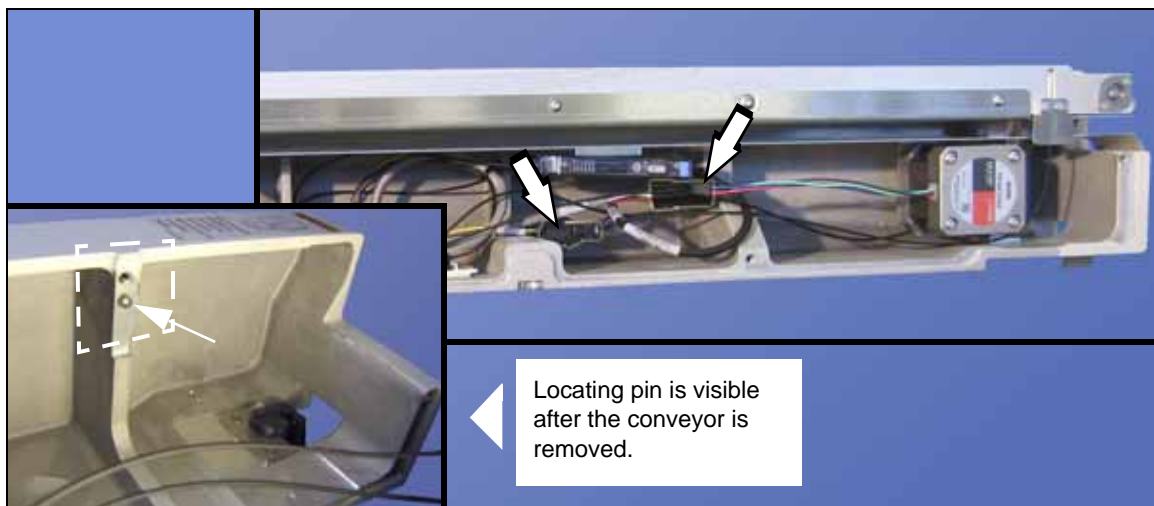

Figure 18—Conveyor Wire Connectors.



For Conveyor screw locations see Figure 17.

7. Remove the two screws attaching the Conveyor Module to the chassis.
8. Lift the Conveyor Module free of the RoadRunner chassis.

### Reinstalling the Conveyor Module

To reinstall the conveyor, reverse the removal steps, plus perform the following:

1. Notice the conveyor locating pin on the chassis. You may need to lift the Conveyor Module slightly to engage the pin.
2. Check that no wires are pinched between the Conveyor and the chassis.



Push probe here with finger.

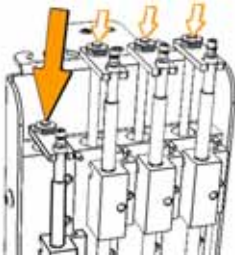

3. Set the conveyor height as follows:
  - 3a. With the RoadRunner in its normal upright position and the conveyor fasteners snug but not tightened, move the PNP Head by hand so it is over the conveyor belt.
  - 3b. Place your thinnest device on the belt below Probe 1.
  - 3c. Lower Probe 1 fully (pushing on the nut directly above the probe stem). With the probe fully extended, adjust the conveyor height so there is approximately a 1 mm gap between the probe tip and the device on the belt. Then tighten the conveyor fasteners.
  - 3d. Recheck the height after tightening the fasteners.

## Adjusting the End-of-Belt Sensor

The End-of-Belt Sensor Optic stops the conveyor belt when devices reach the pick point. The optic operates by sending a beam across the pick point between two fiber optic sensors. When a device breaks the beam, the End-of-Belt Optic stops the belt. The most likely indication that the End-of-Belt Optic is out of adjustment or broken, is that devices fall off the end of the conveyor.

If devices are falling off the end of the conveyor, first test to make sure the optical fiber amplifier is operating (see below). If the sensor is operating, but devices are still passing the pick point, reattach the optical fiber amplifier.

### Testing the End-of-Belt Sensor

1. From the top level menu select *Robot Diagnostics*.
2. Select *Belt*.
3. Select *Pick Sensor*.

---

**CAUTION:** Collision hazard. Make sure that the SMT Machine is stopped and that it is safe to open the safety shield before reaching into the work area.

---

4. With the SMT gantry safely stopped out of the way, put your finger at the SMT pick point to block the sensor optic (see next image below).
5. The Control Panel display will show *Pick Sensor: 1* whenever your finger is blocking the beam, and *Pick Sensor: 0* when not blocked.



Figure 19—Testing the End-of-Belt Sensor. [SIPLACE X model shown.]

6. If *Pick Sensor: 1* is not displayed when the beam is blocked,
  - 6a. check to make sure that all the sensor wires and fiber optics are connected properly.
  - 6b. the Conveyor Module may need to be replaced.
7. If *Pick Sensor: 1* does display, see “Reteaching the End-of-Belt optical fiber amplifier,” below.



For more information, see “Removing the Conveyor Module Cover” on page M-10.



The Optic fiber Amplifier is mounted to the chassis under the Conveyor Module. See Figure 20.

#### **Reteaching the End-of-Belt Optical Fiber Amplifier**

1. Remove the Conveyor Module Cover.
2. Clean the conveyor belt: with isopropyl alcohol on a lint-free cloth, clean the exposed portion of the belt and then dry it.
3. Press the Emergency Stop button—the conveyor belt can now be rotated by hand.
4. Rotate the belt (toward SMT machine) and clean and dry this section. Repeat until the entire belt is clean and dry.
5. Manually rotate the belt so that the optical fiber amplifier displays its highest value.
6. At this spot, place a device on the SMT pick point so it blocks the optic beam.
7. Push *Set* on the optical fiber amplifier.

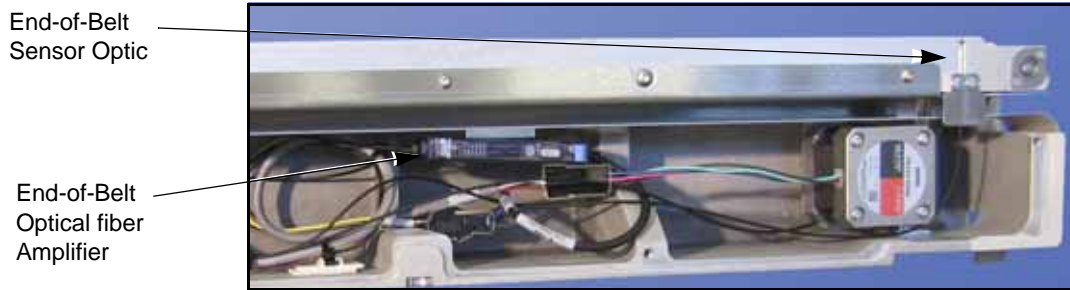

Figure 20—Retaching the End-of-Belt Sensor.

8. Remove the device from the belt and then rotate the belt (toward SMT machine) until the optical fiber amplifier displays its lowest value.
9. Push *Set* on the optical fiber amplifier again.

*NOTE: In general, the End-of-Belt Optical fiber Amplifier should display a number less than 21 when a device is present at the SMT pick point and greater than 90 when no device is present. If it is not possible to achieve numbers less than 21 and greater than 90 by adjusting the optic beam, the conveyor module must be replaced. (The Optical fiber Amplifier must always operate in “Turbo” mode.)*



For details on setting the Optical fiber Amplifier see the label on the inside of the Conveyor Cover shown in Figure 21.

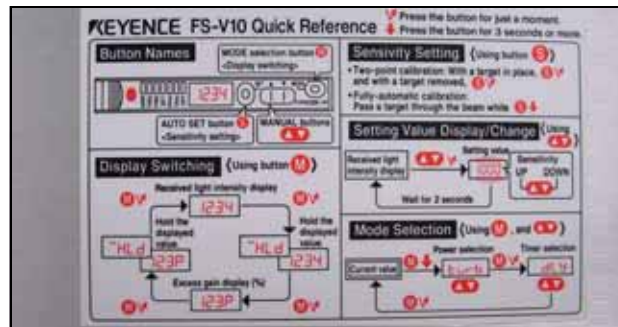

Figure 21—End-of-Belt Optical fiber Amplifier Label on the Conveyor Cover.

M10

M10

Blank page

M10

M10

## Reject Bin

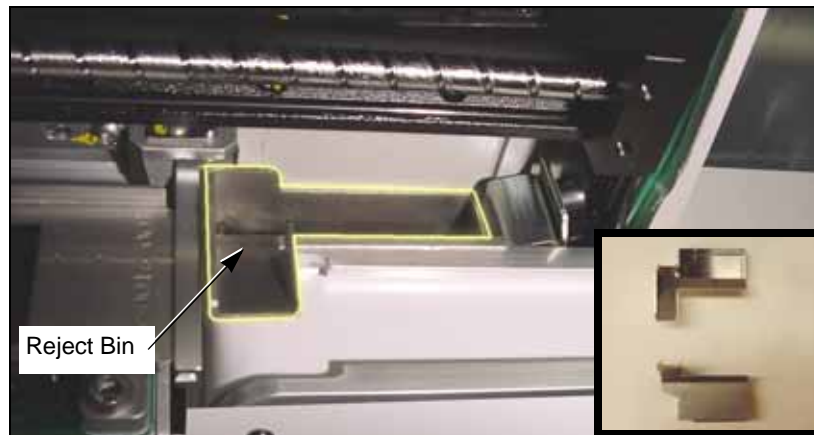

Figure 22—The Reject Bin

The Reject Bin is not fastened in, and therefore is ready to be lifted out of the RoadRunner. Lift up and then out.

The Reject Bin-*Full* Sensor senses when the bin is full and requires emptying. The Reject Bin-*Present* sensor senses the bin's presence. The sensors are attached to the Reject Bin Bracket.

M10

### Data I/O Parts Ordering Information

**Instructions:** 1. Copy this page. 2. Fill in your RoadRunner model and serial numbers (see the label on the chassis under the Robotics Cover). 3. Fill in the quantity for the item(s) desired. 4. (Optional) Call your local Data I/O sale representative for part prices or use our Web page for Requesting Quotes. 5. E-mail to OrderAdmin@dataio.com or FAX to 425-867-6972 with your purchase order. Lighter colored items are for the Large Format models only.

ProLINE-RoadRunner Model No. \_\_\_\_\_ Serial No. \_\_\_\_\_

Sales Part Number	Part Description	Qty	Price Ea.	Totals
RR-ASSY REJECT BIN	Reject Bin		\$	\$
RR-REJECT BIN SENSOR	Reject Bin-Full Sensor		\$	\$
RR-SLOT SENSOR CABLE	Reject Bin-Present Sensor		\$	\$
ASSY,REJECT BIN,RR-uC	Reject Bin, Large Format		\$	\$
			\$	\$

Signature: \_\_\_\_\_ Date: \_\_\_\_\_ Company: \_\_\_\_\_

M10

## Removing the Reject Bin Sensors



For more information, see “Removing the Conveyor Module” on page M-27.

1. Turn the power off.
2. Disconnect the power cord and air supply.
3. Lift off the Robotics Cover.
4. Push the head away from the programmer.
5. Remove the Lower Cover.
6. Remove the Conveyor Module screws (the wires do not need to be unplugged) and lift the module out of the way.
7. Lift out the Reject Bin.
8. Unplug the sensor wire connectors J1C and J1C2 from the Interconnect Panel. Cut wire ties as necessary.
9. Remove three socket head screws securing the Reject Bin Bracket to the chassis and lift it out.

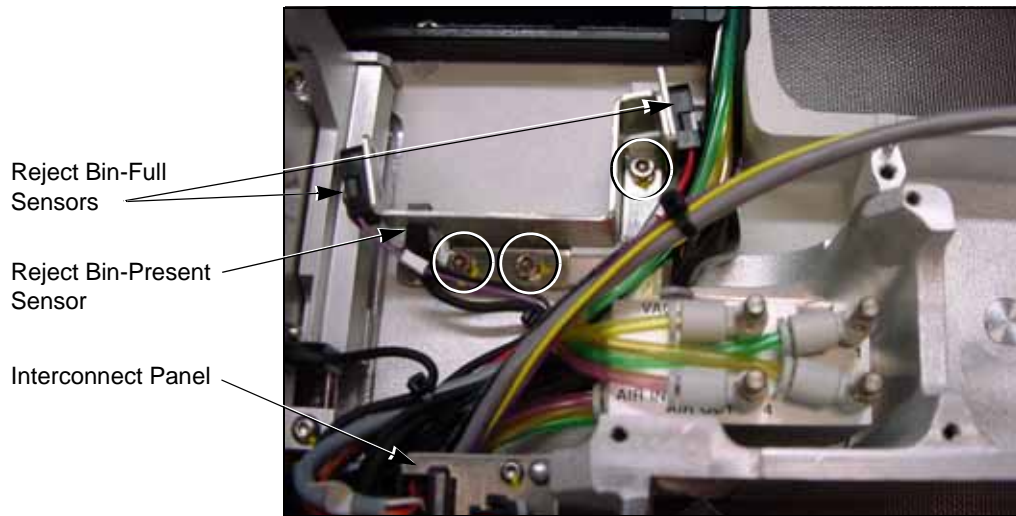

Figure 23—Reject Bin Sensors and Bracket Screw Locations.

10. Unscrew one screw through each sensor to remove the sensor.

*NOTE: The Reject Bin-Full Sensor consists of two sensors. They should be replaced as a set.*



For reinstalling the Conveyor Module see page M-27.

- To install the Reject Bin-Full Sensor, reverse the removal procedures:
- Reinstall the Sensors and the Reject Bin Bracket
  - Reinstall the Conveyor Module. Set the Conveyor height as described in “Reinstalling the Conveyor Module.”
  - Reinstall the Lower Cover.

# Control Panel Module

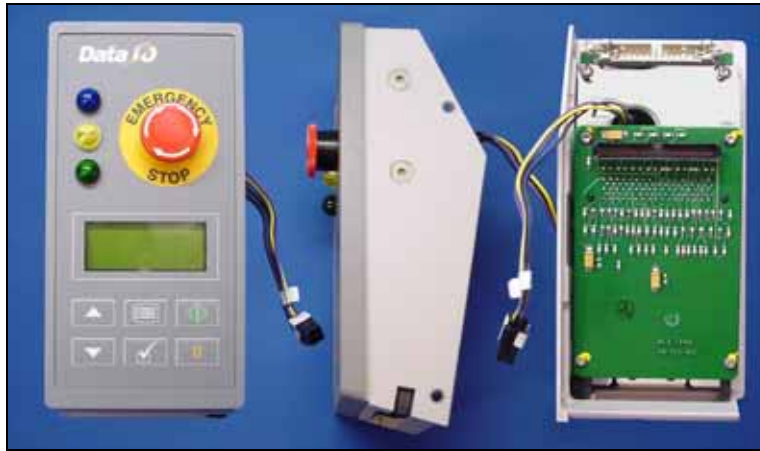

Figure 24—Control Panel Module

The Control Panel Module consists of the PC-Card Drive, the E-Stop button, the Indicator Lamps, Control Panel buttons and LCD screen. If any of the components in the Control Panel Module are not operating correctly, check the wiring connections and the condition of the PC-Card.

Trouble with PC-Cards is often because the card has become corrupt or was incorrectly formatted (must be FAT 16, not FAT 32).

Test the PC-Card Drive with a card that is known to function. If components are still not functioning after connections are tested, return the Control Panel Module to Data I/O for repair.

*NOTE: Do not disassemble the Control Panel Module. If a component is not functioning, send the entire Control Panel Module back to Data I/O.*

## Data I/O Parts Ordering Information

**Instructions:** 1. Copy this page. 2. Fill in your RoadRunner model and serial numbers (see the label on the chassis under the Robotics Cover). 3. Fill in the quantity for the item(s) desired. 4. (Optional) Call your local Data I/O sale representative for part prices or use our Web page for Requesting Quotes. 5. E-mail to OrderAdmin@dataio.com or FAX to 425-867-6972 with your purchase order.

ProLINE-RoadRunner Model No. \_\_\_\_\_ Serial No. \_\_\_\_\_

Sales Part Number	Part Description	Qty	Price Ea.	Totals
RR-CONTROL PANEL M	Control Panel Module		\$	\$
			\$	\$
			\$	\$

Signature: \_\_\_\_\_ Date: \_\_\_\_\_ Company: \_\_\_\_\_



## Removing the Control Panel Module



For more information, see  
“Removing the Robotics  
Cover” on page M-9.

1. Pause the RoadRunner.
2. When the blue lamp is on, turn the power off.
3. Disconnect the RoadRunner power cord and air supply.
4. Remove the Robotics Cover.
5. Remove the PCMCIA Ribbon Cable Guard by unscrewing the two screws securing it.

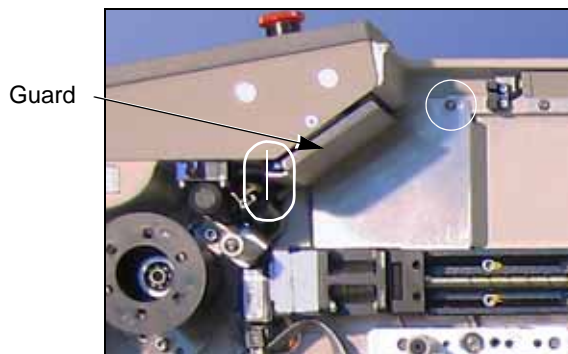

Figure 25—Ribbon Cable Guard with Screw Locations Indicated.

6. Unplug the PC-Card Drive ribbon cable, the Control Panel ribbon cable, and the wires for the Emergency Stop button.

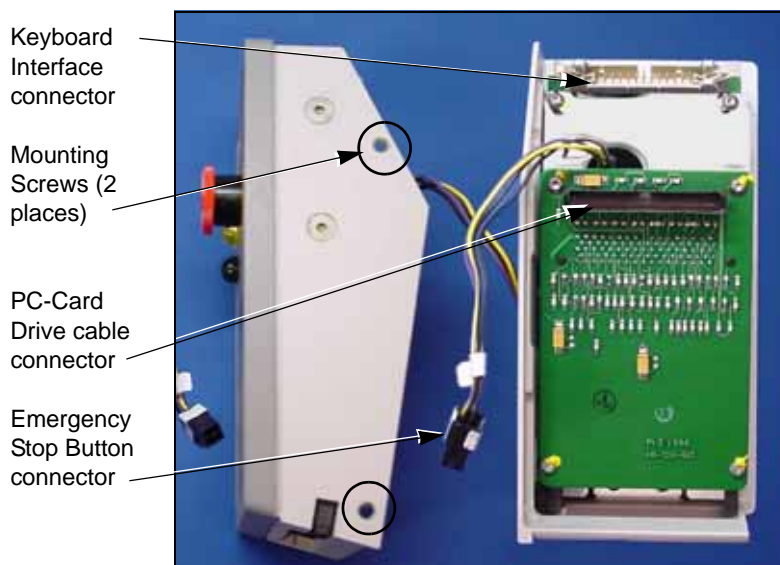

Figure 26—Location of Connectors and Screws on the Control Panel.

7. Remove the two screws securing the Control Panel Module to the RoadRunner chassis.
8. Remove the Control Panel Module.

Replacement is the in the reverse order of removal.

When reassembled, verify the proper operation of the following:

- Card Reader and indicator lamps
- Display
- Keypad
- Emergency Stop

## Pick and Place Head

The head assembly contains four probes, each with Vacuum Tips and Vacuum Chamber Blocks. Some parts can be replaced and some probe functions can be adjusted.

### Aligning Pick and Place Points

Since device placement tolerance is small, the system may need aligning when a module is replaced or repaired. The head may also need aligning if any of the following error messages are displayed:

- Device pick failure at input, with probe *n*.
- Device pick failure on probe *n*.
- Device dropped from probe *n*.

For system alignment procedures see “Setting the *Tape* Parameter” and “Setting the *Skt 1* Parameter” under the heading “Setting Operational Parameters” in Chapter 3 of the Owner’s Manual.

### Adjusting and Balancing Probe Speed

If the probe speed is too fast, devices in the carrier tape become unsettled as a probe strikes a device during the pick routine. If the probe speed is too slow, throughput will suffer and device placement problems may occur.

Adjust the probe speed with power and pressurized air on. Ensure that vacuum to all probes is disabled before starting this procedure. The easiest way to ensure this is to cycle the power.



See “Loading Device Tape” and “Aligning the Device Tape” in Chapter 3 of the Owner’s Manual.

#### Part A

1. Load and align the device tape without peeling off the cover tape. (The Cover Tape Peel Bar and Spool will not be used.)

**WARNING**



**Pinch point:** Moving mechanical parts. Keep hands away from moving parts. The following procedures require the Robotics Cover to be removed while mechanical parts are in motion. Use caution.

2. Scroll to and select *Robot Diagnostics*.
3. Scroll to and select *Probe 1*.
4. Scroll to and select *Speed*. The probe will move to the device pick point and cycle continuously.
5. Read the speed that is now displayed in the screen. The speed should be  $140 \pm 4$ . If it needs adjustment skip to Part B.

If it does not need adjustment:

- 5a. Press *Menu*.
- 5b. Scroll to and select the next probe.
- 5c. Repeat from step 4 for each probe.

End of Part A.

**Part B:**

**! WARNING**

 **Electric shock hazard.** Do not touch any electronics that become exposed when the cover(s) is removed. Use caution and heed the following instructions closely.

6. Remove power from the RoadRunner.
7. Remove the Lower Cover and the Conveyor Module Cover.
8. Locate the Probe Interface Manifold: it is mounted on the chassis below and to the right of the Reject Bin.

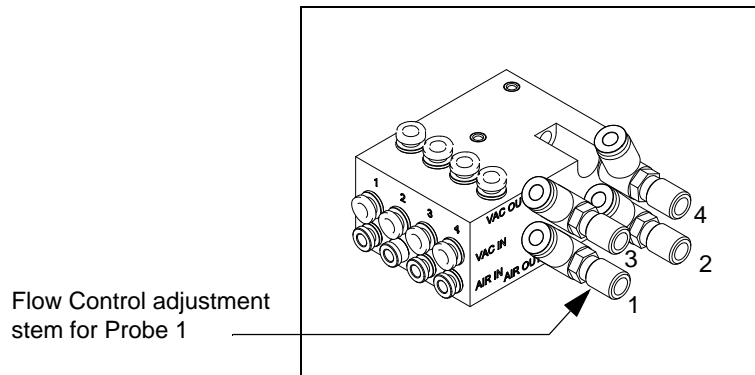

Figure 27—Interface Manifold  
(Adjustment stems have screwdriver slots.)

9. Adjust the Probe Speed flow control for Probe 1 (or current probe) while watching the speed displayed at the keypad screen.
10. When the speed is within the proper range ( $140 \pm 4$ ), press *Menu*—probe motion will stop.
11. Tighten the locknut ring on the Flow Control if applicable to your model.
12. Recheck the speed. If it is outside the proper range then readjust.
13. Scroll to and select the next probe.
14. Repeat steps 4 and on for the next probe.
15. When finished, see Adjusting Probe-Raising Speed (next heading).

M10

M10

## Adjusting Probe Raising Speed

*NOTE: Probe lowering speed should be set first. See “Adjusting and Balancing Probe Speed” on page M-37.*



For more information . . .  
See “Loading Device Tape” and “Aligning the Device Tape” in Chapter 3 of the Owner’s Manual.

If the probe-raising speed is too fast, devices may rotate excessively after a pick operation and cause alignment problems; devices may even fall off the probes. It could also bend the motion limit pin on the PNP Head. To adjust the probe-raising speed:

1. Load and align the device tape without peeling off the cover tape. (The Cover Tape Peel Bar and Spool will not be used.)

 **WARNING**



**Pinch point:** Moving mechanical parts. Keep hands away from moving parts. The following procedures require the Robotics Cover to be removed while mechanical parts are in motion. Use caution.

2. Scroll to and select *Robot Diagnostics*.
3. Scroll to and select *Probe 1*.
4. Scroll to and select *Speed*. The probe will move to the device pick point and cycle continuously.

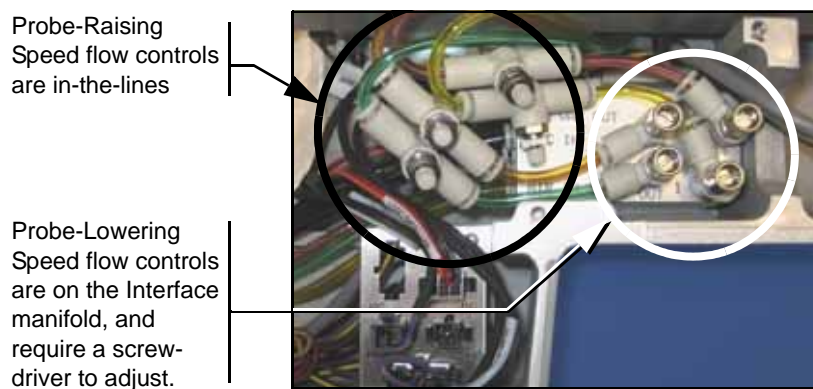

*Figure 28—The in-line flow controls for adjusting the Probe Speed. Probe numbers are stamped on the manifold.*

5. Watch the probe to observe the probe-raising speed. The probe should be fully up the very instant that the head jogs back and forth a couple millimeters.

If the probe is fully up too soon (before the head jogs) or too late (after



For more information see  
“Covers” on page M-8.

the head jogs), remove the Lower Cover and the Conveyor Module Cover.

6. Loosen the locknut ring on the in-line Flow Control for Probe 1 (or current probe).
7. Manually adjust the speed by hand using the knob on the in-line flow control for Probe 1 raising speed (see figure above). Adjust the probe-raising speed until it synchronizes with the head jog.
8. Tighten the locknut ring.
9. Press Menu to deselect the current probe.
10. Scroll to and select the next probe.
11. Repeat these steps (from step 4 and on) for each probe.
12. This procedure affects the probe down speed slightly. See the previous heading “*Adjusting and Balancing Probe Speed*” and recheck the probe speed.
13. When finished, replace both covers and remove the device tape.

## Resetting the *Pick* Delay and *Travel* Delay Times

The delay times do not change and do not usually require adjustment. The factory-set values are indicated in the following flow charts.

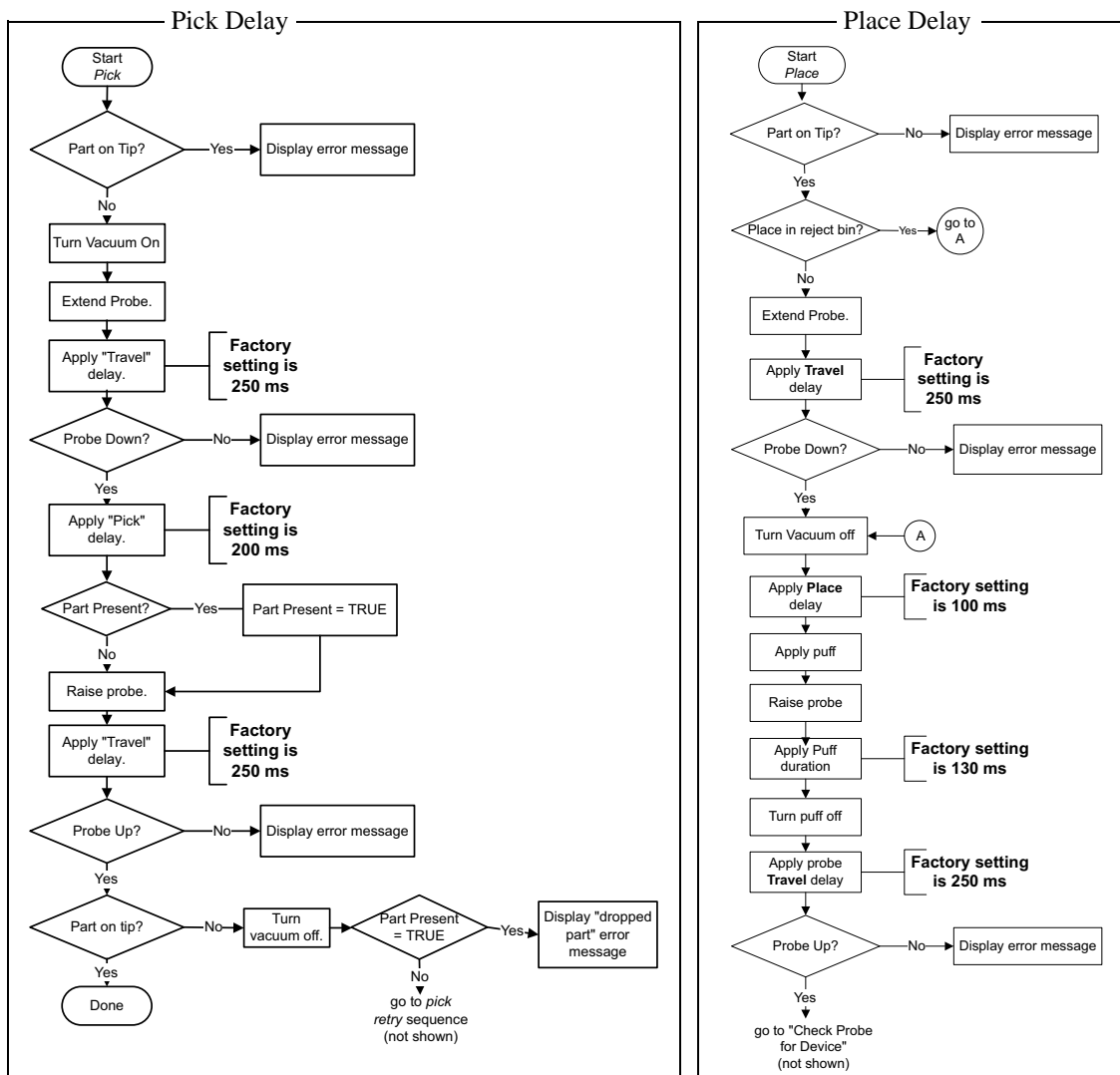

Figure 29—Pick and Place Delay Flow Charts

**NOTE:** Changes to these values are not recommended.

These values only affect the internal verification delay time, as indicated in the flow charts. To reset delay times:

1. From the top level menu on the display, select *Operation*.
2. Scroll to and select *Probes*.
3. Scroll to and select the setting you wish to adjust.

4. Use the *Arrow Up* and *Arrow Down* buttons to change the setting.
5. When finished, select *Menu*.

## Adjusting Probe Vacuum Sensors

1. Turn power off to RoadRunner.
2. Remove the Lower Cover.
3. Turn on shop air to RoadRunner.



4. Turn power on to RoadRunner.
5. Select *Menu* until you reach the top menu level and select *Robot Diagnostics*.
  - 5a. Scroll to and select *Probe 1*.
  - 5b. Scroll to and select *Vacuum*.
  - 5c. Press the *Up Arrow* to enable the probe vacuum.
6. Turn the vacuum sensor adjustment screw for Probe 1 (the first adjustment block) counter-clockwise just until the red LED adjacent to the adjustment screw illuminates.



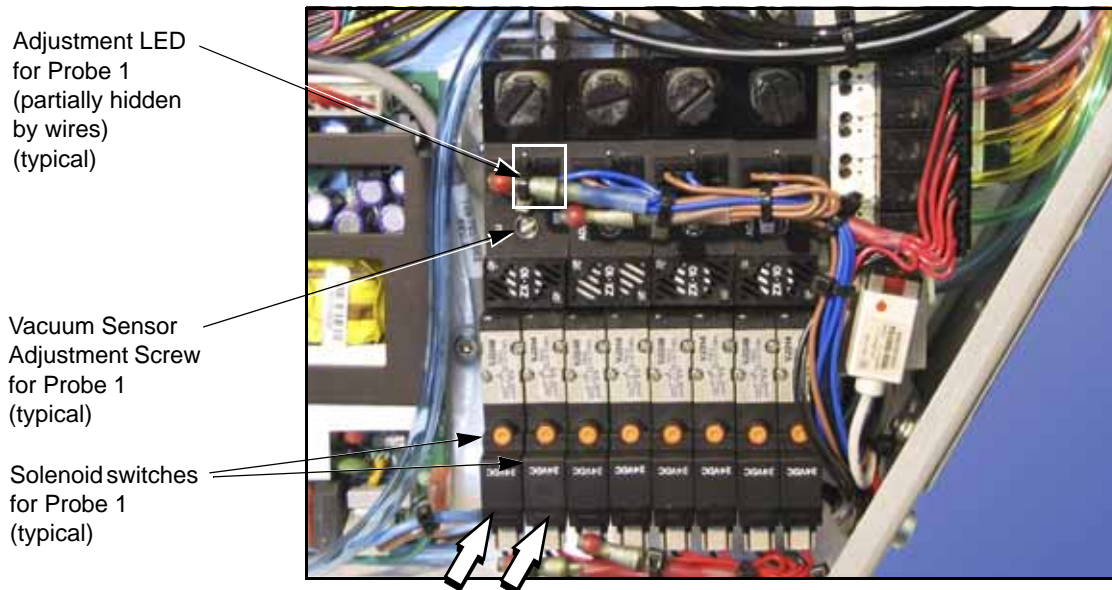

*Figure 30—Pneumatic Valve Block. When the vacuum for Probe 1 is enabled, the small LED on each of the two solenoids (white arrows) for Probe 1 will be unlit.*

- 6a. Then turn the same vacuum sensor adjustment screw 1 revolution clockwise until the red LED goes out. Continue turning the screw 1/2 to 1 more revolution clockwise.
- 6b. Test the setting by blocking air at the probe tip with your finger. The LED should illuminate. Adjust if necessary.
7. Press the down arrow to disable vacuum.
8. Press *Menu* twice to move up to *Probe*.
9. Press the down arrow to select Probe 2.
10. Repeat steps from 5b and on for each probe.
11. Turn the power off to RoadRunner.
12. (Optional) Turn the air off.
13. Re-install the Cover when finished.

## Removing the PNP Head

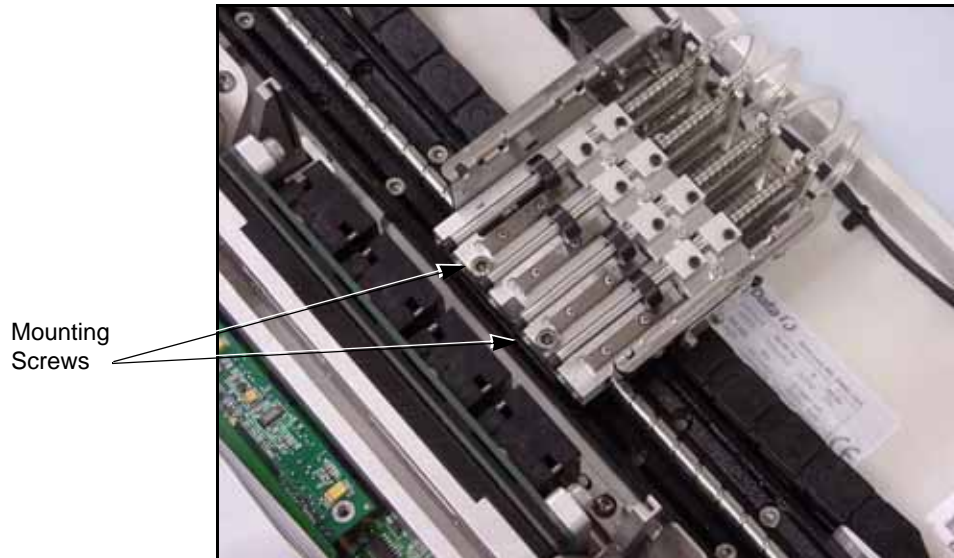

Figure 31—Removing the PNP Head

If you receive error messages relating to the Pick and Place function, refer to the troubleshooting chapter in the Owner's Manual.

If you experience trouble with the Pick and Place Head that is not covered in this manual, remove the head and send it to Data I/O Customer Service for repair or replacement.

Removal procedures are on the following page.

## Data I/O Parts Ordering Information

**Instructions:** 1. Copy this page. 2. Fill in your RoadRunner model and serial numbers (see the label on the chassis under the Robotics Cover). 3. Fill in the quantity for the item(s) desired. 4. (Optional) Call your local Data I/O sale representative for part prices or use our Web page for Requesting Quotes. 5. E-mail to OrderAdmin@dataio.com or FAX to 425-867-6972 with your purchase order.

ProLINE-RoadRunner Model No. \_\_\_\_\_ Serial No. \_\_\_\_\_

Sales Part Number	Part Description	Qty	Price Ea.	Totals
PNP HEAD - 4 PROBE	Pick and Place Head		\$	\$
RR-VAC TIP	Vacuum,tip,4.57 mm OD		\$	\$
6070173006	PNP Head Bracket		\$	\$
RR-CHAMBER FLOATING BLOCK	Vacuum Chamber Block		\$	\$

Signature: \_\_\_\_\_ Date: \_\_\_\_\_ Company: \_\_\_\_\_



For screw locations see [Figure 30 on page M-43](#).

To remove the Pick and Place Head:

1. Turn the power off.
2. Disconnect the RoadRunner power cord and air supply.
3. Remove the Robotics Cover.
4. Label and disconnect the tube from the top of each probe.
5. Remove two socket head cap screws attaching the head to the ball screw carriage [3 mm hex key].
6. Lightly pull the head a couple of centimeters away from the carriage.
7. Label each of the four pneumatic tubes. With a slotted screwdriver, remove the pneumatic tubes with fittings from the back of the head. Note that each has a washer.

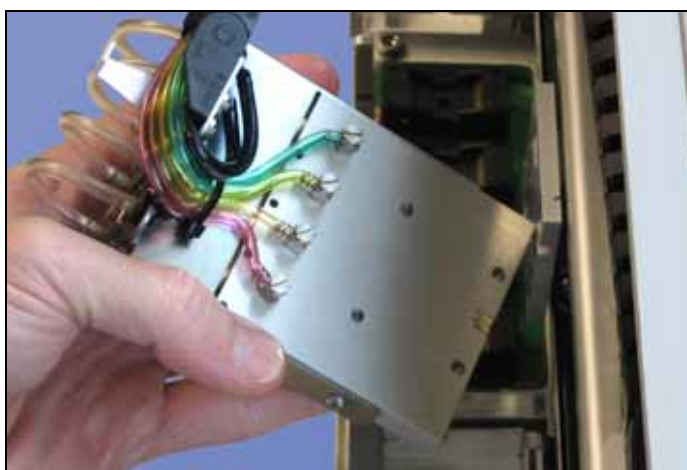
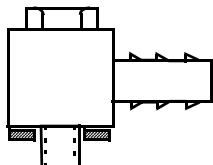

Figure 32—The four fittings on the back of the PNP Head. The PNP Head has been unbolted from the Linear Stage Module.

8. Remove two Head Bracket screws from each side of the head [2 mm hex key].



Tube Fitting and Gasket.



For more information, see the “[Linear Stage Installation Verification](#)” on page [M-62](#).

To reinstall a PNP Head, reverse the steps for removal *and* perform the following:

1. Install the four fittings onto the new head—the tubes are still attached. Ensure that each has a gasket.
2. Install the head Bracket onto the head.
3. Attach the tubes to the probes.
4. Install the head to the Linear Stage with the two socket screws. Use Loctite 222 or equivalent.
5. Perform the “Linear Stage Reinstallation Verification” procedure.

# Programmer Module

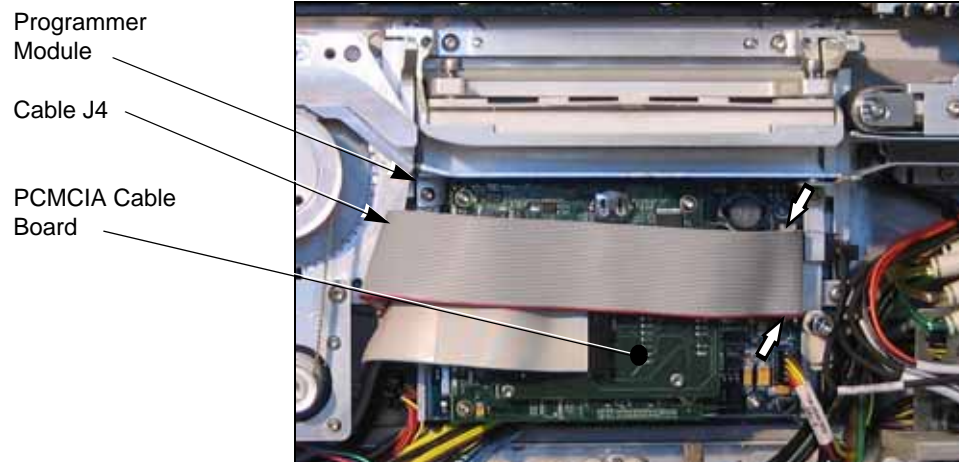

Figure 33—Programmer Module. The ribbon cable connector is indicated with two arrows.

The Programmer Module consists of the WaveForm Board, Main Controller Board, BackPlane Board, the Socket Adapter, and the Socket Actuator that opens and closes the programmer sockets.

If Socket Adapter sockets become worn, the Socket Adapter needs attention. The Socket Adapter needs cleaning when yield drops, and needs replacing when cleaning fails to boost yield. If replacing the Socket Adapter does not solve problems in the Programmer Module, see “Diagnosing with the Adapter Board” in Chapter 5 of the Owner’s Manual, or contact Data I/O for Programmer Module replacement or repair.



For more information, see “Changing the Socket Adapter” in Chapter 3 of the Owner’s Manual.

## Data I/O Parts Ordering Information

**Instructions:** 1. Copy this page. 2. Fill in your RoadRunner model and serial numbers (see the label on the chassis under the Robotics Cover). 3. Fill in the quantity for the item(s) desired. 4. (Optional) Call your local Data I/O sale representative for part prices or use our Web page for Requesting Quotes. 5. E-mail to OrderAdmin@dataio.com or FAX to 425-867-6972 with your purchase order.

ProLINE-RoadRunner Model No. \_\_\_\_\_ Serial No. \_\_\_\_\_

Sales Part Number	Part Description	Qty	Price Ea.	Totals
7502327002	ASSY,PROGRAMMER W/GUIDE,FC2		\$	\$
7502423001	ASSY,PROGRAMMER W/GUIDE,FC3		\$	\$
6950019001	Programmer Alignment Tool		\$	\$

Signature: \_\_\_\_\_ Date: \_\_\_\_\_ Company: \_\_\_\_\_

## Removing the Programmer Module

*NOTE: Only technicians who have taken the ProLINE-RoadRunner Service training course should attempt to remove the Programmer Module.*

*A special tool (Programmer Alignment Tool) is required from Data I/O to reinstall the Programmer Module. See the order form on the previous page. (This tool is also included in the Self-Service Spares Kit.)*



For more information, see “Changing the Socket Adapter” in Chapter 3 of the Owner’s Manual.

For more information, see “Removing the Conveyor Module” on page M-27.

1. Switch the power off.
2. Disconnect the RoadRunner power cord and air supply.
3. Lift off the Robotics Cover.
4. Push the head away from the programmer.
5. Remove the Lower Cover.
6. Remove the Actuator Plate by sliding it out of the bracket.
7. Optional: Remove the Socket Adapter.
8. Remove the Conveyor Module Cover.
9. Lift out the Reject Bin.
10. Remove screws from the Conveyor Module and set the Module aside—wires are still attached.
11. Remove the Reject Bin Bracket. Sensors do not need to be removed. Wires do not need to be unplugged. Move it out of the way.

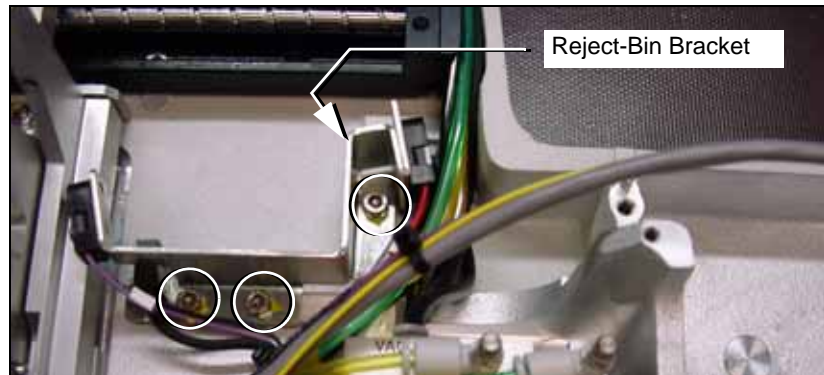

Figure 34—Reject Bin Bracket Screw Locations

**CAUTION:** Ribbon cables can get damaged if pulled or pinched. Cable damage is often not visible. Pull cables by the connector only.



Cables are identified in Figure 35 below.

12. Unplug the ribbon cable J4 from the Programmer Module.
13. Unplug the Cable J3 from the Programmer Module.
14. Remove the PCMCIA-PCB by removing four socket-head cap screws and lifting up on the PCB. Set it aside—the cable is still attached.
15. Unplug the Motion Controller Cable (709-0560) from the left side of the Programmer Module.
16. If equipped, unplug the Ethernet Cable (701-3215) from the left side of the Programmer Module, adjacent to the Motion Controller Cable.

Cable J4 connector

Cable J3 connector

PCMCIA-Cable PCB

Ethernet Cable Connect

Motion Controller Cable Connect

Empty



Figure 35— Cable Connectors and PCMCIA-PCB fasteners on FCIII.



To locate the Flow Control and Cable J5C, see Figure 36.

17. Disconnect the air tube from the Programmer Module at the Flow Control. It is a one-touch fitting.
18. Disconnect the Programmer Module's Actuator Position Sensor Cable, J5C, from the Cable Interconnect Panel. Cut the cable ties.

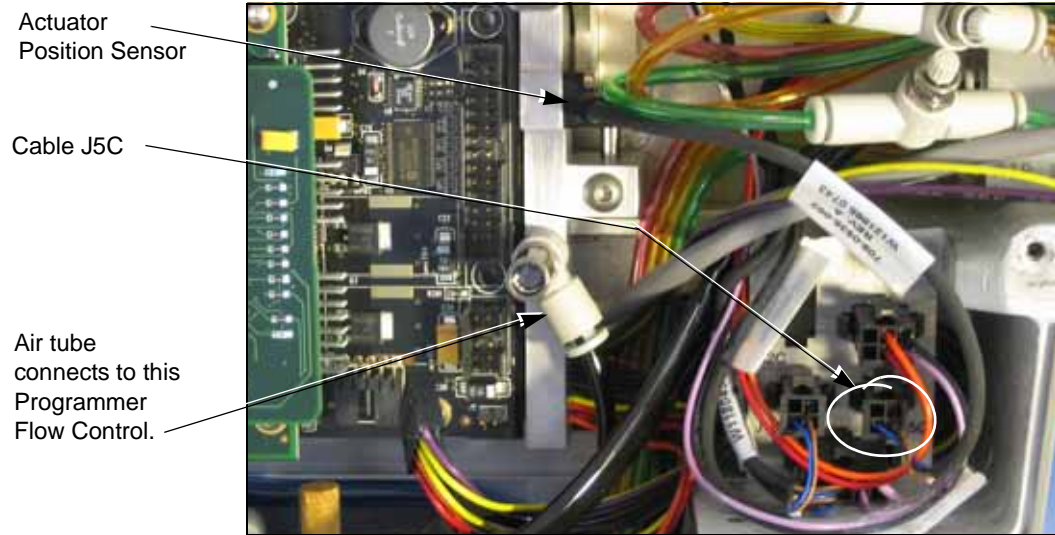

Figure 36—Cable Interconnect Panel. Cables J3 and J4 have been unplugged.

19. Remove four button head socket screws attaching the Programmer Module to the chassis.

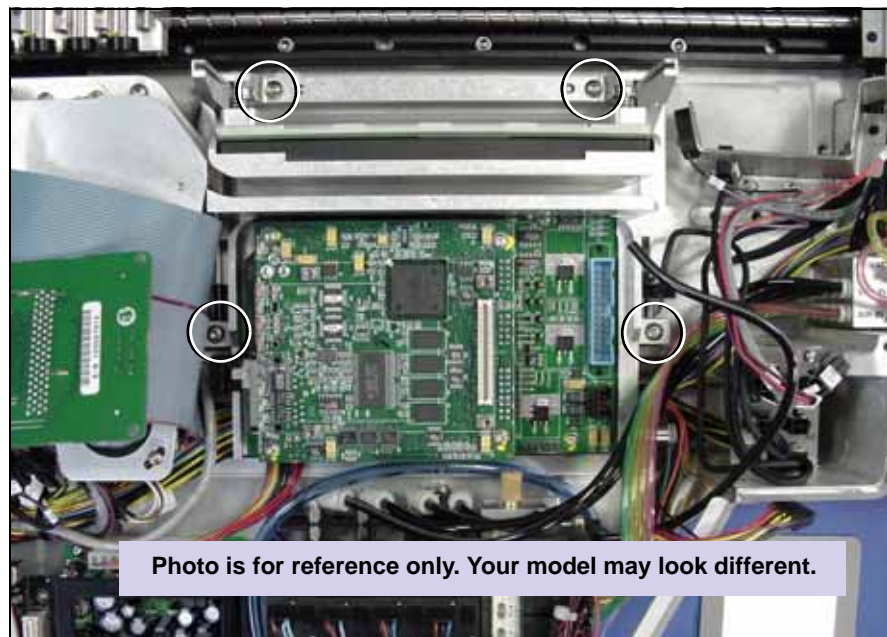

Figure 37—Location of Programmer Screws

20. Lift the Programmer Module out from the chassis.

M10

M10

**Reinstalling the Programmer Module**

To reinstall a Programmer Module, perform the following steps:

1. Plug the Ethernet Cable (if present) and RJ45 Motion Control Cable into the left side of the Module.
2. Reinstall the Programmer Module ensuring that no wires or hoses are pinched, and tighten the four screws.
3. Reconnect the air tube.
4. Reinstall all cable connectors.
5. Plug in the PCMCIA-PCB and install the four screws.
6. Reinstall the Reject Bin.

Align the Programmer Module as described below before completing reinstallation.

**Aligning the Programmer Module**

Align the Programmer Module as follows:

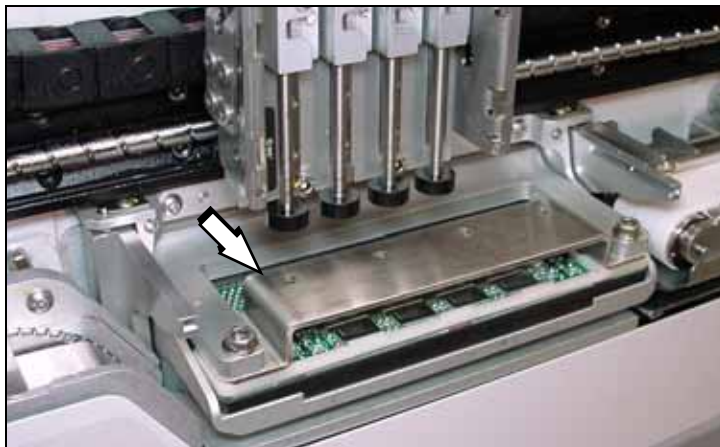

*Figure 38—The Programmer Module Alignment Tool Installed on the Programmer.*

---

**CAUTION:** Chassis can get damaged. Loosen the Programmer Module mounting screws (two upper screws, refer to [Figure 37](#)) before each attempt to adjust the Programmer Alignment Screws (refer to [Figure 39](#)).

---

1. Install the Programmer Alignment Tool (sales part number is PROGRAMMER ALIGNMENT TOOL) onto the Programmer Module in place of a Socket Adapter.
2. Remove the rubber tip and vacuum chamber block from Probe 1 (the far left probe) and extend Probe 1 into the alignment tool hole #1. If the



probe **passes** through the hole easily, then the left side of the programmer is properly aligned—skip to step 3.

- 2a. If Probe 1 **does not pass** through easily, loosen the upper left Programmer Module mounting screw two revolutions. (See figure below.)
- 2b. Adjust the left Position Alignment set screw (adjacent to the mounting screw) with a 2 mm hex key so that the probe does pass through easily. Turn the screw clockwise to move the module away from the chassis.
- 2c. When done, tighten the upper left Programmer Module screw.

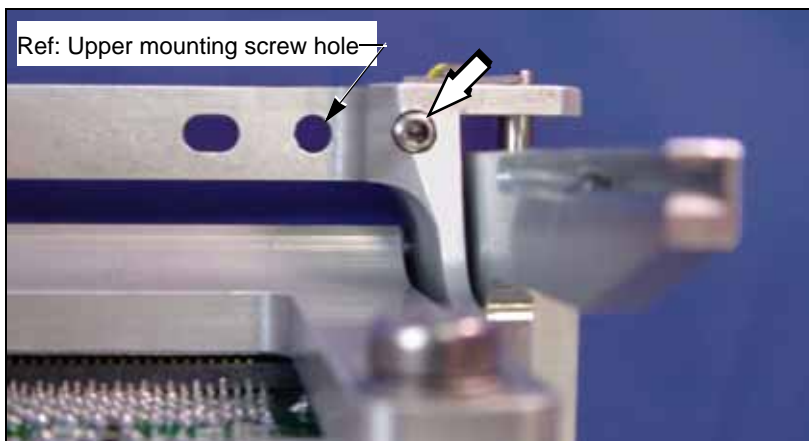

Figure 39—Programmer Module Alignment Screws (the screw on the left side is not shown).

3. Remove the rubber tip and vacuum chamber block from Probe 4 and extend it into the alignment tool hole #4. If the probe **passes** through the hole easily, then the right side of the programmer is properly aligned—skip to step 4.
  - 3a. If probe 4 **does not pass** through easily, loosen the upper right Programmer Module mounting screw two revolutions.
  - 3b. Adjust the right Position Alignment set-screw accordingly.
  - 3c. When done, tighten the upper right programmer mounting screw.
4. **Retest.**  
If the module requires further adjustment, be sure to loosen the left or right mounting screw first.
5. Remove the Alignment Tool.
6. Replace the vacuum chamber blocks and rubber probe tips.

Complete the Programmer Module installation by installing the Reject Bin Bracket, and the Conveyor Module. (Covers should get installed after the next section.)

### **Adjusting the Actuation Speed**

The programmer actuation speed needs to be adjusted so that it doesn't slam the Actuator Plate down onto the sockets. If it is too fast, causing a hard

landing, devices may bounce. For the steps below, refer to [Figure 36 on page M-49](#).

1. Install a Socket Adapter and Actuator Plate.
2. Plug in the AC Power cable.
3. Connect external air source ensuring that it is set to approximately 5.17 Bars (75 PSI).
4. Press the Emergency Stop button to prevent the PNP Head from moving.

---

**CAUTION:** Pinch hazard. Keep hands and fingers away from the PNP Head, Gantry lead screw, and programmer actuator.

The E-Stop does not stop the programmer from actuating—opening and closing the sockets.

**CAUTION:** Shock hazard. The E-Stop does not stop electrical flow to internal electronics.

---

M10



When installing or removing any Electronics cover, remove power from RoadRunner.

5. Insert a job card with Supervisor authority and switch the power on.
6. Pause the RoadRunner.
7. When the blue lamp is lit, turn the power off.
8. Disconnect the RoadRunner power cord and air supply.
9. Remove the Robotics Cover.

**WARNING**



**Electric shock hazard.** The following procedures require the Electronics Cover(s) to be removed while power is on. Only touch items described in the procedures. Use caution.

10. Reattach the RoadRunner power cord and air supply.
11. Turn power and air back on.
12. Locate the Actuation Flow Control and adjust it counter-clockwise to full open, then turn it clockwise 2-1/2 revolutions.
13. At the Control Panel, press *Menu*. Then scroll to and select **Robot Diagnostics > Socket > State**. After selecting the **State** command a dot, or bullet, appears next to it. Then the *Down Arrow* and *Up Arrow* buttons will actuate the programmer. **KEEP FINGERS AWAY FROM THE PROGRAMMER AND ACTUATOR PLATE.**

M10

14. Actuate the programmer and watch the speed. If the actuator appears to hit the sockets too hard, adjust the flow control and then retry. Use the flow control to soften the impact. However, setting speed too slow may cause timing problems as well as reduced throughput.
15. Turn power off.
16. Disconnect RoadRunner power and air supply.
17. Reinstall the Robotics cover.
18. Reinstall the power cable and air supply.
19. Turn RoadRunner power and air supply back on.

# NVRAM Battery

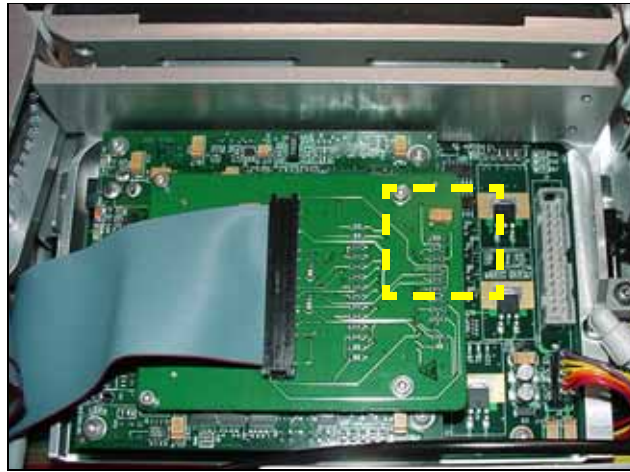

Figure 40—The Programmer: Ribbon cable J4 (not shown) is disconnected. The NVRAM Battery is on the far side of the second board down. If you had X-ray vision, you could see it where the dashed, yellow square is drawn.

RoadRunner uses a lithium battery to power the non-volatile read-only memory (NVRAM). If information stored in NVRAM is lost, RoadRunner will not function correctly. If RoadRunner displays the error message **NVRAM Battery Failed**, NVRAM data will be lost when RoadRunner is switched off, and the battery will need to be replaced.

After a new battery has been installed in RoadRunner, perform the simple procedure (which follows the battery replacement instructions) to reteach the PNP Head positions, the Socket Status, Network Settings, and the time and date.

It takes approximately 40 minutes to replace the battery and an additional 20 minutes to reteach the system.

## Data I/O Parts Ordering Information

**Instructions:** 1. Copy this page. 2. Fill in your RoadRunner model and serial numbers (see the label on the chassis under the Robotics Cover). 3. Fill in the quantity for the item(s) desired. 4. (Optional) Call your local Data I/O sale representative for part prices or use our Web page for Requesting Quotes. 5. E-mail to OrderAdmin@dataio.com or FAX to 425-867-6972 with your purchase order.

ProLINE-RoadRunner Model No. \_\_\_\_\_ Serial No. \_\_\_\_\_

Sales Part Number	Part Description	Qty	Price Ea.	Totals
RR-BATTERY PACK, LITHIUM	NVRAM Battery		\$	\$
			\$	\$
			\$	\$

Signature: \_\_\_\_\_ Date: \_\_\_\_\_ Company: \_\_\_\_\_

## Removing the NVRAM Battery

The battery is an integral part of the PowerCap Module. The entire PowerCap cap must be replaced. The PowerCap Module is located on the back side of the RPX\_LITE circuit board.

1. Switch the RoadRunner power off.
2. Disconnect RoadRunner power cord and air supply.
3. Lift off the Robotics Cover.
4. Remove the Lower Cover.
5. Unplug ribbon cable J4 from the Programmer Module and move it out of the way. See figure.

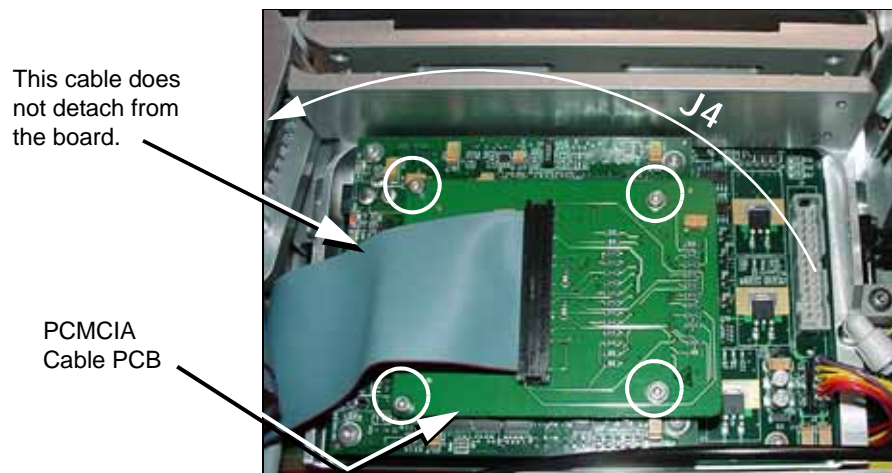

Figure 41—Ribbon cable J4 (not shown) has been disconnected from the programmer. PCMCIA-PCB screws are circled.

6. Remove the PCMCIA-PCB by removing four socket-head cap screws and lifting the PCB up. Lay it aside—the cable is still attached. See figure above.
7. Remove four socket-head screws securing the RPX\_LITE board to the Waveform PCB and lift the board up. See figure below.



Figure 42—The RPX-Lite screws are circled. (The PCMCIA-PCB has been removed.)

8. Turn the board over and locate the PowerCap Module.

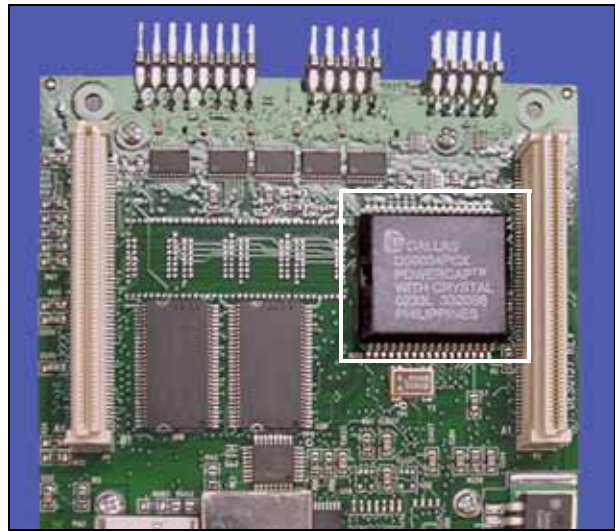

Figure 43—The PowerCap Module on the RPX-Lite PCB.

9. Insert a small slotted screwdriver into the PowerCap cap slot.
10. Gently pull back the screwdriver handle until the side of the cap releases from the module base. See figure below. Remove the cap.

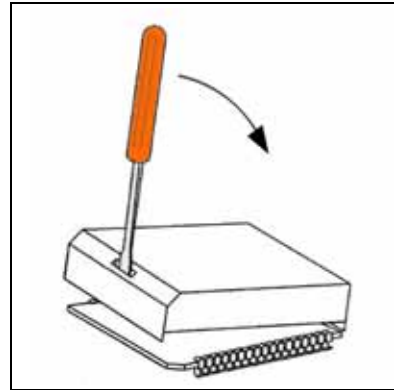

Figure 44—Removing the cap from the base.

## Installing a new NVRAM Battery

1. Align the new PowerCap cap contact springs (tabs) with the base contact lands.
2. Hook the PowerCap cap flange under the module base board. Center the cap on the base. See figure below.
3. Push down on the cap until the side with the slot snaps onto the base.

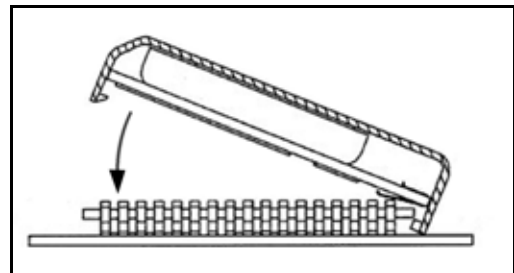

Figure 45—Attaching a new PowerCap cap (NVRAM battery) to the PowerCap Module base.

## Reinstalling Components

Reinstallation of components is in reverse order of removal. Briefly: install the RPX-Lite board, install the PCMCIA-PCB, plug in ribbon cable J4, install the Lower Cover.

## Reteaching the NVRAM

After a new battery has been installed in RoadRunner, you need to teach it the PNP Head positions, the Socket Status, Network Settings, and the time and date so that they can be stored again in NVRAM. The following procedures are covered in more detail in the RoadRunner Owner's Manual as noted in many of the steps below.

To reteach the NVRAM,

1. Connect the air supply and power cord to RoadRunner.
2. Switch the power on.
3. Insert a PC card with Supervisor Authority into RoadRunner. For help on setting Supervisor Authority, open TaskLink and click **Help > Help Topics > Menus > Tools Menu > Set Administrator Privileges > How to Set Administrative Privileges**.
4. Press the Menu button on the RoadRunner Control Panel.

### Head Positions

1. Teach the Tape pocket position—see *Setting the Tape Parameter* in Chapter 3 of the Owner's Manual.
2. Teach the Socket 1 position—see *Setting the Skt 1 Parameter* in Chapter 3 of the Owner's Manual.
3. Teach the Reject Bin position—see *Setting the Reject Parameter* in Chapter 3 of the Owner's Manual.
4. Teach the Belt position—see *Setting the Belt Parameter* in Chapter 3 of the Owner's Manual.

### Network Values

If your RoadRunner is networked to a computer with TaskLink, you need to configure the network settings again.

1. Use the Network Wizard in TaskLink (**Tools > Create Network Configuration Card**) to create a Network Configuration card. (Generally, the previous network values are automatically inserted except a zero or a dummy number will be placed into the IP address field.) Enter data for the IP address, Programmer Port, Subnet Mask and Gateway. When done click **Finish**.
2. Remove the PC card and insert the card into the target RoadRunner.
3. Scroll to and select **System > Network > Network Parm**.
4. Press the *Down Arrow* to change **Network Parm** to **Card**.
5. Cycle the power on the RoadRunner.



*The RoadRunner IP, Programmer Port (**Prog Port**), Subnet Mask (**Sub**), and Gateway (**GTW**) are listed in the RoadRunner menu under **System > Network**.*



***Reteaching the Time settings***

To set the time:

1. Press the *Menu* button.
2. In the top level menu, scroll to and select **System > Time**.
3. Scroll to Hour.  
Set to the correct hour as follows:
  - Press *Select*
  - Adjust number with the *Up Arrow* or *Down Arrow*
  - Press *Menu* to save.
4. Scroll to each remaining parameter (**Minutes, Month, Day, Year**) and set in the same manner.

# Linear Stage Module

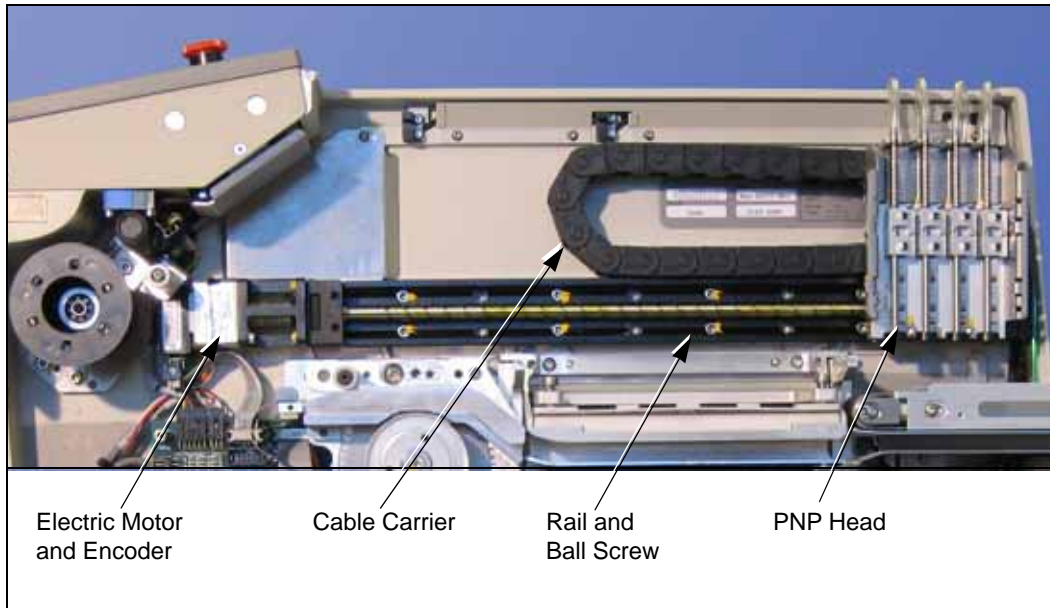

Figure 46—The Linear Stage Module

M10



To remove the PNP Head only, see “Removing the PNP Head” on page M-44.

The Linear Stage, part of the Robotic System, consists of a rail and ball screw, a stepper motor with encoder, and a cable carrier. The Linear Stage is removed as a module with the PNP Head.

## Data I/O Parts Ordering Information

**Instructions:** 1. Copy this page. 2. Fill in your RoadRunner model and serial numbers (see the label on the chassis under the Robotics Cover). 3. Fill in the quantity for the item(s) desired. 4. (Optional) Call your local Data I/O sale representative for part prices or use our Web page for Requesting Quotes. 5. E-mail to OrderAdmin@dataio.com or FAX to 425-867-6972 with your purchase order.

ProLINE-RoadRunner Model No. \_\_\_\_\_ Serial No. \_\_\_\_\_

Sales Part Number	Part Description	Qty	Price Ea.	Totals
RR-LINEAR MODULE	Linear Stage Module		\$	\$
			\$	\$
			\$	\$

Signature: \_\_\_\_\_ Date: \_\_\_\_\_ Company: \_\_\_\_\_

M10

## Removing the Linear Stage Module



See “Removing the Lower Cover” on page M-9.



See “Removing the Conveyor Module Cover” on page M-10.

1. Switch the power off.
2. Disconnect the RoadRunner power cord and air supply.
3. Lift off the Robotics Cover.
4. Remove the Lower Cover.
5. Remove the Conveyor Module Cover.
6. Remove the Conveyor Module screws (the wires do not need to be unplugged) and lift it out of the way.
7. Lift out the Reject Bin.
8. (Label if necessary and) disconnect four *black* Linear Stage air hoses from the Probe Control Manifold’s upper surface. The Probe Control Manifold is located below the Reject Bin Bracket.
9. (Label if necessary and) disconnect four *colored* air hoses from the Probe Control Manifold.
10. Unplug electrical connector J8B from the extension cable connector. It goes to the linear stage motor. The cable is tucked beneath the Tape-In Module and pulls out far enough for connector access. See figure below.

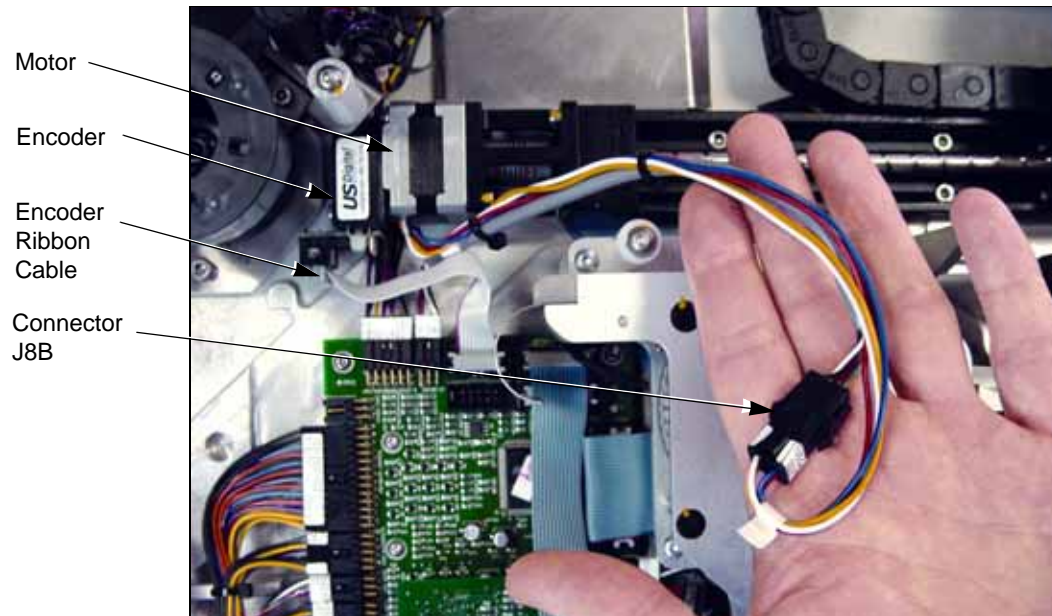

Figure 47—Wires from the Linear Stage Motor terminate at intermediate connector J8B beneath the Tape-In Module.

11. Unplug the ribbon cable at the Linear Stage Encoder.
12. Remove eight screws securing the Linear Stage Module to the chassis. (Slide the head out of the way as necessary.) See the figure below.

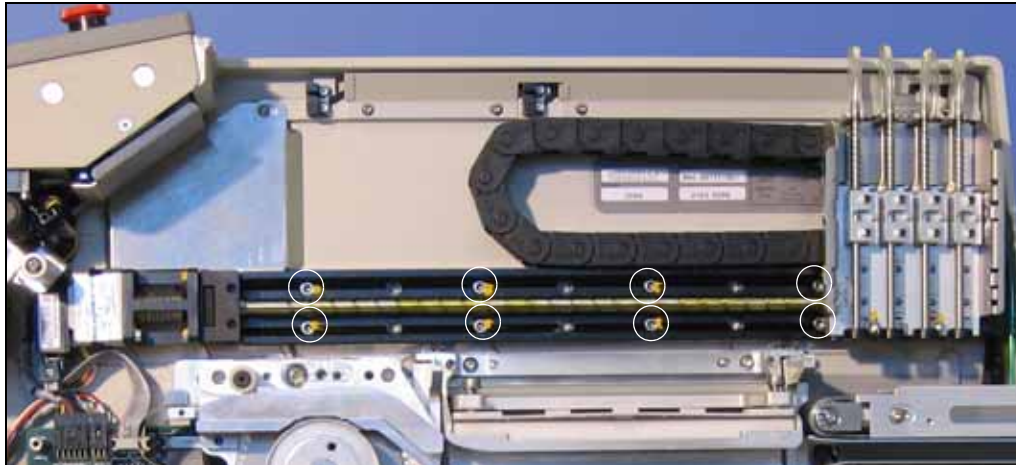

Figure 48—Linear Stage Screw Locations.

### Linear Stage Installation Verification

To replace the Linear Stage Module, reverse the steps for removal *and* perform the following:

1. For Conveyor Module reinstallation, see heading *Reinstalling the Conveyor Module* earlier in this manual.
2. With the power off, slide the PNP Head along the entire length of the Linear Stage. Check that the Head Flag (small bracket on top the head) clears the position sensors.
3. Verify electrical and pneumatic connections as follows:
  - 3a. Connect the air hose and turn the power on.
  - 3b. Verify that the head homes.
  - 3c. Verify that the *Position* field at the keypad display toggles when each probe is lowered by hand. *Robot Diagnostics » Probe X » Position*.
  - 3d. Extend and retract each probe to verify correct plumbing. *Robot Diagnostics » Probe X » Position » Arrow Up/Down*.
  - 3e. Enable vacuum to each probe to verify correct plumbing. *Robot Diagnostics » Probe X » Vac Sense » Arrow Up/Down*.
4. Adjust the Probe Vacuum Sensors.
5. Verify correct Probe Speed.
6. Perform the “Aligning the Programmer Module” procedure.
7. Reteach the robot the four operation parameters: *Tape*, *Socket1*, *Reject* and *Belt*.



For probe vacuum settings see “Adjusting Probe Vacuum Sensors” on page M-42.

For probe speed information see “Adjusting and Balancing Probe Speed” on page M-37.

For Programmer alignment see “Aligning the Programmer Module” on page M-50.

For reteaching the robot see “Setting Operational Parameters” Chapter 3 of the Owner’s Manual.

## Spares Kits

Kits of spare parts prevent long delays if you experience down time due to part wear or failure. There are two types of spares kits: a Basic Spares Kit and a Self-Service Spares Kit. The Self-Service Spares Kit contains more parts and requires technicians who have attended an Advanced RoadRunner Service course to replace the components. Each of these two spares kits is available for several different RoadRunner models. Spares kits for other versions may have become available since the printing of this manual. Use the Sales Numbers below to order your spares kit, or contact Data I/O Sales.

### Spares Kits for Specific Models

Model	Basic Spares Kit Sales Number	Self-Service Spares Kit Sales Number
<b>Standard FC III</b>	RR-SPARES KIT-M10	RR-SELFSV SPARES-FC3-M10
<b>Standard FC II</b>	(same as FC III)	RR-SELFSV SPARES-FC2-M10
<b>Large Format</b>	RR-SPARES KIT-LF-M10	—

Contents of some of the kits are listed on the following pages.

#### **Some Differences Among Specific Models**

FlashCORE III (FC III) is the latest programming architecture for the standard RoadRunner (at time of printing this manual).

Large Format (LF) RoadRunner is for programming devices whose length is larger than 15 mm and/or height (thickness) is larger than 3 mm.

*NOTE: The LF RoadRunner picks and places with only two probes at a time to accommodate the larger devices.*

Model / Maximum device size	Length (mm)	Width (mm)	Height (mm)
Standard	15	21.65	3
Large Format (LF)	24	21.65	6
XLF <sup>1</sup>	32	32	6

<sup>1</sup>The XLF model is not covered in this manual.

On RoadRunner, device width is perpendicular to the direction of device tape travel.

# Basic Spares Kit, Standard RoadRunner

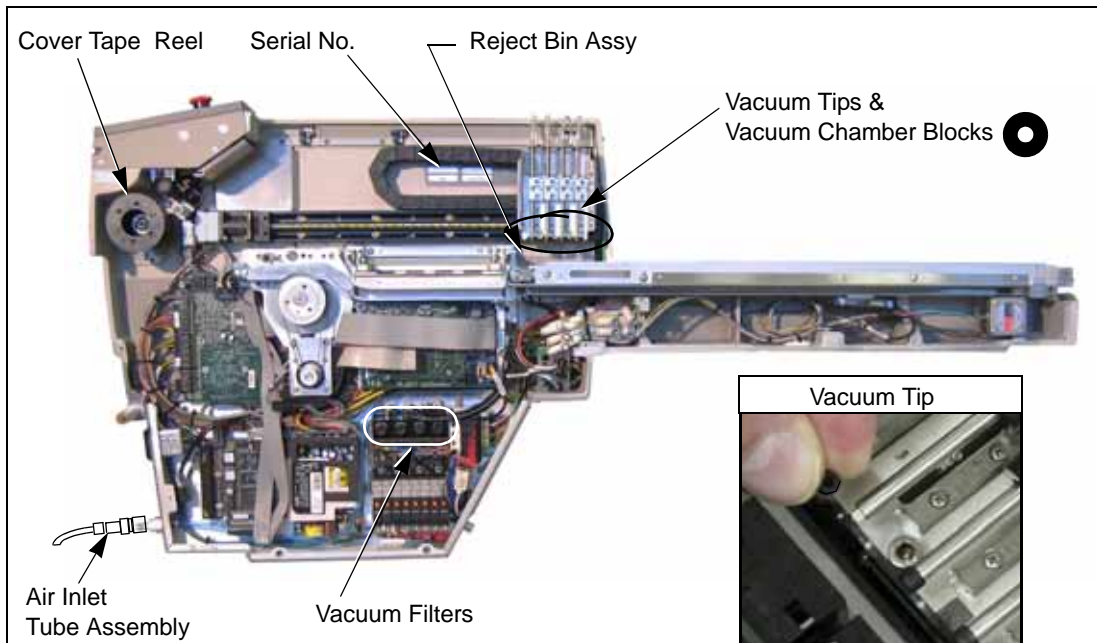

Figure 49—Parts in the Basic Spares Kit; Standard RoadRunner.

Two spare parts kits are available for each Standard RoadRunner. Parts in the Basic Spares Kit are listed below. For the larger kit, “Self-Service Spares Kit,” see [page M-66](#).

## Data I/O Parts Ordering Information

**Instructions:** 1. Copy this page. 2. Fill in your RoadRunner model and serial numbers (see the label on the chassis under the Robotics Cover). 3. Fill in the quantity for the item(s) desired. 4. (Optional) Call your local Data I/O sale representative for part prices or use our Web page for Requesting Quotes. 5. E-mail to [OrderAdmin@dataio.com](mailto:OrderAdmin@dataio.com) or FAX to 425-867-6972 with your purchase order.

ProLINE-RoadRunner Model No. \_\_\_\_\_ Serial No. \_\_\_\_\_

Sales Part Number	Part Description	Qty	Price Ea.	Totals
RR-VAC TIP	Probe Tip		\$	\$
RR-VAC FILTER	Vacuum Filter		\$	\$
RR-ASSY AIR TUBE	Air Inlet Tube Assembly		\$	\$
RR-ASSY REJECT BIN	Reject Bin Assy		\$	\$
RR-SLEEVE TAKEUP WHEEL6HL	Cover Tape Take-Up Reel, 6 Holes		\$	\$
RR-CHAMBER FLOATING BLOCK	Vacuum Chamber Block		\$	\$
RR-FILTER AIR 1/4-3/8	Filter, Air, 1/4 - 3/8		\$	\$
RR-FILTER MIST SEP 1/4-3/8	Filter, Mist separator		\$	\$
RR-SPARES KIT-M10	Spares Kit FCII & FCIII (all above)		\$	\$

Signature: \_\_\_\_\_ Date: \_\_\_\_\_ Company: \_\_\_\_\_

## Replacing the Probe Tips

The rubber tip pulls straight off. To install a rubber tip, hold it with the square hole oriented to the square end of the probe and work it onto the probe.

## Replacing the Air Inlet Tube Assembly

To remove the Air Inlet Tube Assembly at the RoadRunner air connector:

1. Stop or pause the job if one is running.
2. If there are any devices currently on the probes, remove them; they will fall off when air is removed.
3. Pull the collar on the quick release fitting back as you pull the tube assembly off the connector. (The quick release fitting, often called a one-touch fitting, has a safety shut off feature—the compressed air need not be turned off.)

To connect an Air Inlet Tube Assembly, push it onto the RoadRunner connector.

# Self-Service Spares Kit, Standard RoadRunner

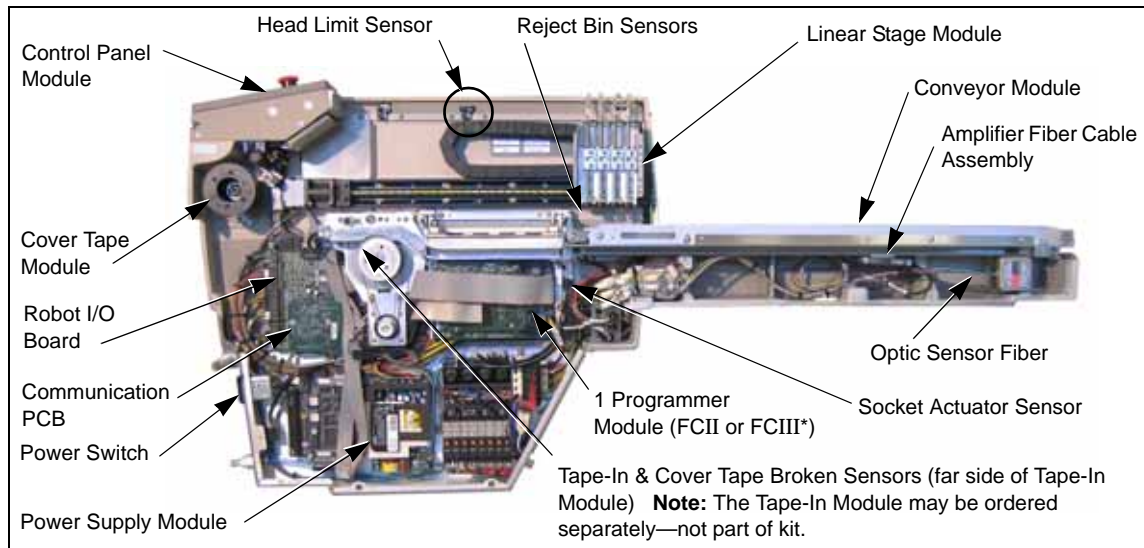

Figure 50—Parts in the Self-Service Spares Kit; Standard RoadRunner

## Data I/O Parts Ordering Information

**Instructions:** 1. Copy this page. 2. Fill in your RoadRunner model and serial numbers (see the label on the chassis under the Robotics Cover). 3. Fill in the quantity for the item(s) desired. 4. (Optional) Call your local Data I/O sale representative for part prices or use our Web page for Requesting Quotes. 5. E-mail to OrderAdmin@dataio.com or FAX to 425-867-6972 with your purchase order.

ProLINE-RoadRunner Model No. \_\_\_\_\_ Serial No. \_\_\_\_\_

Sales Part Number	Part Description	Qty	Price Ea.	Totals
RR-PWR SWITCH	Power Switch, Rocker		\$	\$
RR-PWR SUPPLY	Power Supply Module		\$	\$
RR-REJECT BIN SENSOR	Reject Bin Sensor (Cable Assy)		\$	\$
RR-LIMIT SENSOR CABLE	Head Limit Sensor (Cable Assy)		\$	\$
RR-SLOT SENSOR CABLE	Slot Sensor Cable Assembly (Tape)		\$	\$
RR- OPTIC SENSOR	Optical Sensor Fiber		\$	\$
RR-LINEAR MODULE	Linear Stage Module		\$	\$
7502417001	Conveyor Module		\$	\$
7502423001	Programmer Module FC III*		\$	\$
7502327002	Programmer Module FC II*		\$	\$
RR-CTRL PNL MODULE	Control Panel Module		\$	\$
RR-PCMCIA CABLE	Control Panel Cable		\$	\$
RR-COVER TAPE MOD	Cover Tape Module		\$	\$
RR-ROBOT I/O COMM	Robot I/O Board Module		\$	\$
RR-FIBER OPTIC CA	Amplifier Fiber Cable Assembly		\$	\$
RR-SMT COMM PORT	Communications PCB		\$	\$
RR-PNEUMATIC MODULE	Pneumatic Module		\$	\$
RR-DIAGNOSTICS BOARD	Diagnostics Adapter Board (DAB)		\$	\$
PROGRAMMER ALIGNMENT TOOL	Programmer Alignment Tool		\$	\$

Signature: \_\_\_\_\_ Date: \_\_\_\_\_ Company: \_\_\_\_\_



The Self-Service Spares Kit for Standard RoadRunner contains parts listed on [page M-66](#). It is available to those who have attended an Advanced RoadRunner Service course.

---

*NOTE: When ordering, make sure that the kit designates the correct FlashCORE programmer (FC2 or FC3 for example): it should match the one you have. A different model programmer will not run your programming jobs or work with your firmware.*

---

### **Customer Training**

For information about advanced training, contact the Data I/O Customer Service Center. A training course may be ordered when purchasing a RoadRunner or at a later time.

---

*NOTE: This manual does not list replacement instructions for all the parts in the Self-Service Spares Kit (such as the Robot I/O Board or the Communications PCB). For additional information, contact Data I/O or your nearest authorized representative. To find your nearest representative, see the instructions on the last page of this manual.*

---

# Basic Spares Kit, Large Format RoadRunner

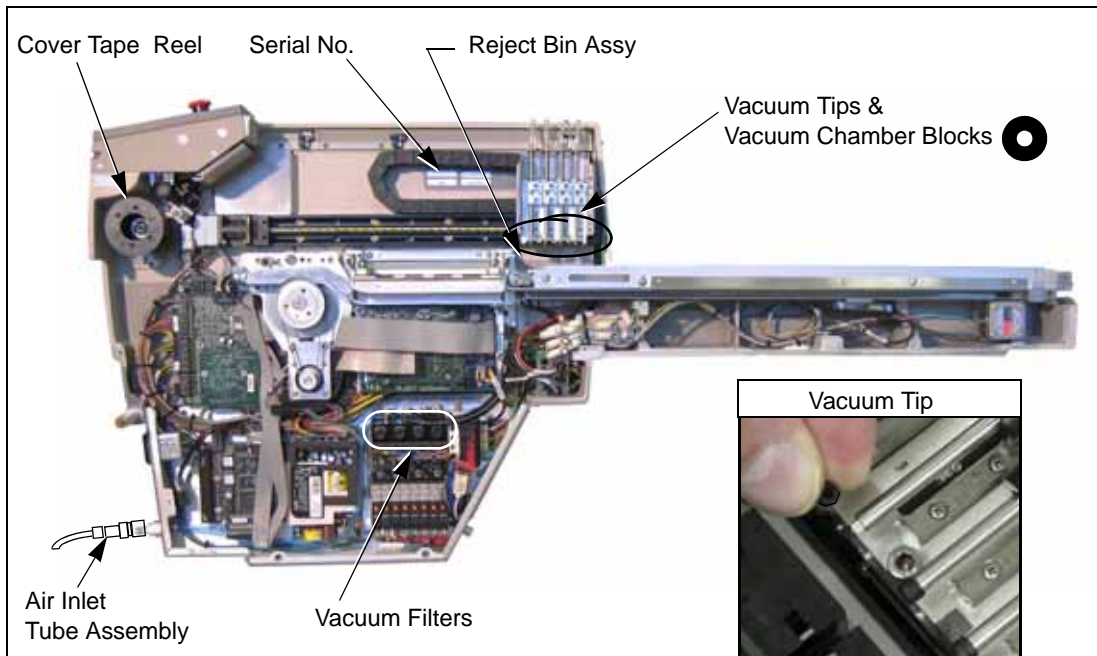

Figure 51—Parts in the Basic Spares Kit; Large Format RoadRunner

Two spare parts kits are available for the Large Format RoadRunner. Parts in the Basic Spares Kit are listed below. For the larger kit, “Self-Service Spares Kit,” see [page M-70](#).

## Data I/O Parts Ordering Information

**Instructions:** 1. Copy this page. 2. Fill in your RoadRunner model and serial numbers (see the label on the chassis under the Robotics Cover). 3. Fill in the quantity for the item(s) desired. 4. (Optional) Call your local Data I/O sale representative for part prices or use our Web page for Requesting Quotes. 5. E-mail to [OrderAdmin@dataio.com](mailto:OrderAdmin@dataio.com) or FAX to 425-867-6972 with your purchase order. Lighter colored items are for the Large Format models only.

ProLINE-RoadRunner Model No. \_\_\_\_\_ Serial No. \_\_\_\_\_

Sales Part Number	Part Description	Qty	Price Ea.	Totals
RR-VAC TIP	Probe Tip		\$	\$
RR-VAC FILTER	Vacuum Filter		\$	\$
RR-ASSY AIR TUBE	Air Inlet Tube Assembly		\$	\$
ASSY,REJECT BIN,RR-uC	Reject Bin Assy, Large Format		\$	\$
RR-SLEEVE TAKEUP WHEEL6HL	Cover Tape Take-Up Reel, 6 Holes		\$	\$
RR-CHAMBER FLOATING BLOCK	Vacuum Chamber Block		\$	\$
RR-FILTER AIR 1/4-3/8	Filter, Air, 1/4 - 3/8		\$	\$
RR-FILTER MIST SEP 1/4-3/8	Filter, Mist separator		\$	\$
RR-SPARES KIT-LF-M10	Spares Kit Large Format (all above)		\$	\$

Signature: \_\_\_\_\_ Date: \_\_\_\_\_ Company: \_\_\_\_\_

## Replacing the Probe Tips

The rubber tip pulls straight off. Hold a new tip with the square hole oriented to the square end of the probe and work it onto the probe.

## Replacing the Air Inlet Tube Assembly

To remove the Air Inlet Tube Assembly at the RoadRunner air connector:

1. Stop or pause the job if one is running.
2. If there are any devices currently on the probes, remove them; they will fall off when air is removed.
3. Pull the collar on the quick release fitting back as you pull the tube assembly off the connector. (The quick release fitting, often called a one-touch fitting, has a safety shut off feature—the compressed air need not be turned off.)

To connect an Air Inlet Tube Assembly, push it onto the RoadRunner connector.

# Self-Service Spares Kit, Large Format RoadRunner

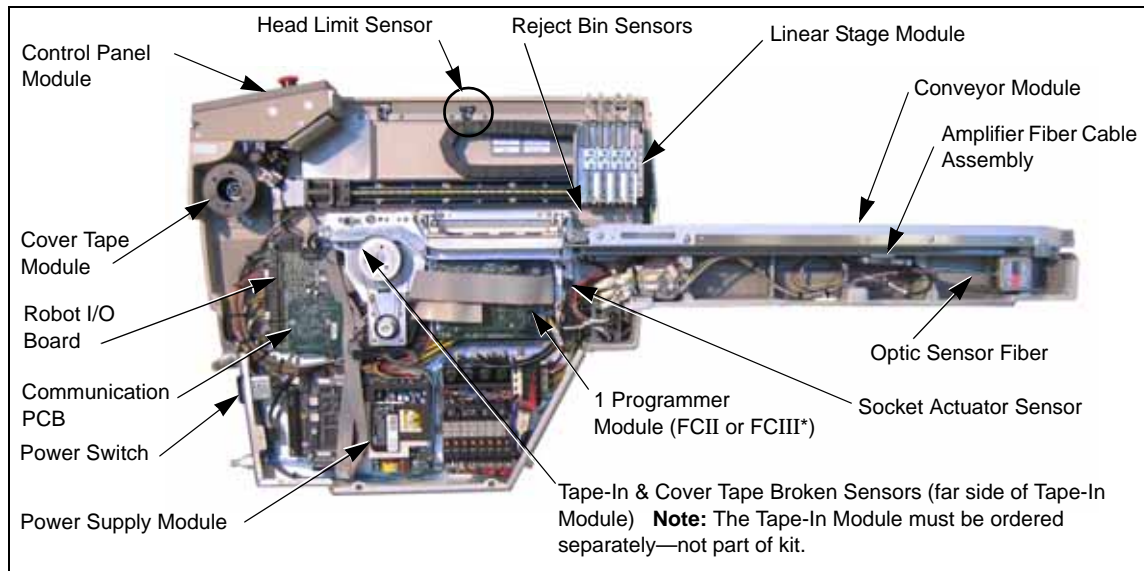

Figure 52—Self-Service Spares Kit; Large Format RoadRunner

## Data I/O Parts Ordering Information

**Instructions:** 1. Copy this page. 2. Fill in your RoadRunner model and serial numbers (see the label on the chassis under the Robotics Cover). 3. Fill in the quantity for the item(s) desired. 4. (Optional) Call your local Data I/O sale representative for part prices or use our Web page for Requesting Quotes. 5. E-mail to OrderAdmin@dataio.com or FAX to 425-867-6972 with your purchase order. Lighter colored items are for the Large Format models only.

ProLINE-RoadRunner Model No. \_\_\_\_\_ Serial No. \_\_\_\_\_

Sales Part Number	Part Description	Qty	Price Ea.	Totals
RR-PWR SWITCH	Power Switch, Rocker		\$	\$
RR-PWR SUPPLY	Power Supply Module		\$	\$
RR-REJECT BIN SENS	Reject Bin Sensor (Cable Assy)		\$	\$
RR-LIMIT SENSOR CA	Head Limit Sensor (Cable Assy)		\$	\$
RR-SLOT SENSOR CA	Slot Sensor Cable Assembly (Tape)		\$	\$
RR- OPTIC SENSOR	Optical Sensor Fiber, side		\$	\$
RR-LINEAR MODULE	Linear Stage Module		\$	\$
7502417001	Conveyor Module,		\$	\$
7502423001	Programmer Module, FCII*		\$	\$
7502327002	Programmer Module, FCIII*			
RR-CTRL PNL MODULE	Control Panel Module		\$	\$
RR-PCMCIA CABLE	Control Panel Cable		\$	\$
RR-COVER TAPE MOD	Cover Tape Module		\$	\$
RR-ROBOT I/O COMM	Robot I/O Board Module		\$	\$
RR-FIBER OPTIC CA	Amplifier Fiber Cable Assembly		\$	\$
RR-SMT COMM PORT	Communications PCB		\$	\$
RR-PNEUMATIC MODULE	Pneumatic Module		\$	\$
RR-DIAGNOSTICS BOARD	Diagnostics Adapter Board (DAB)		\$	\$
PROGRAMMER ALIGNMENT TOOL	Programmer Alignment Tool		\$	\$

Signature: \_\_\_\_\_ Date: \_\_\_\_\_ Company: \_\_\_\_\_

\* Choose one Programmer Module (FCII or FCIII).

The Self-Service Spares Kit for Large Format RoadRunner contains parts listed on [page M-70](#). It is available to those who have attended an Advanced RoadRunner Service course.

### **Customer Training**

For information about advanced training, contact the Data I/O Customer Service Center. A training course may be ordered when purchasing a RoadRunner or at a later time.

---

*NOTE: This manual does not list replacement instructions for all the parts in the Self-Service Spares Kit. For additional information, contact Data I/O or your nearest authorized representative. To find your nearest representative, see the instructions on the last page of this manual.*

---

## Socket Adapter, Actuator, and Precisor



Figure 53—Precisor, Actuator, and Socket Adapter Locations

A precisor is a plate that assists in aligning devices on the probes before they are placed into the programming sockets.

The Actuator Plate opens the sockets on the Socket Adapter (assisted by air cylinders).

The Socket Adapter is the interface between the specific device and the programmer. Socket manufacturers' specifications are used for expected socket life.

Since these three parts—Precisor Plate, Actuator Plate and Socket Adapter—are determined by the device package, they may need to be replaced for each new device type you wish to program. Call Data I/O Customer Service, or contact your nearest authorized Data I/O representative, for parts or device programming kits. Contact information is on the last page of this manual.

See the ProLINE-RoadRunner Owner's Manual for the following:

- To remove the **Precisor** see “Changing the Precisor” in Chapter 3.
- To remove the **Actuator Plate** see “Changing the Actuator Plate” in Chapter 3.
- To remove the **Socket Adapter** see “Changing the Socket Adapter” in Chapter 3.

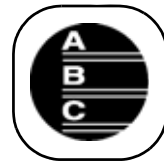

# Index

---

*NOTE: For items not found here, check the RoadRunner Owner's Manual.*

---

## A

Actuator Plate M-72  
Adjustable Tape-In Module  
    aligning M-14  
    removing M-13  
Air Filters  
    description M-16  
    ordering M-16  
    replacing M-17  
Air Paths, keeping clean M-16  
Allowable device sizes M-63

## B

Basic Spares Kit  
    Large Format M-68  
    Standard M-64

## C

Components, listed M-4  
Contact Information. See inside back cover.  
Control Panel  
    removing M-35  
Control Panel Module  
    ordering M-34  
Conveyor Belt Cover, removing M-10

Conveyor Module M-26, M-30, M-66, M-70  
    drop height M-27  
    reinstalling M-27  
    removing M-27  
Cover Tape Module  
    ordering M-24  
    removing M-25  
Covers, ordering M-8  
Customer Training M-67, M-71

## D

Delay Times, resetting M-41  
Device sizes allowed M-63  
Device width M-63

## E

Electrostatic Discharge 1-iii  
End-of-Belt Sensor  
    adjusting M-28  
    reteaching M-29  
    Testing M-28  
ESD. See Electrostatic Discharge

**F**

## Filter

- air M-64, M-68
- vacuum M-64, M-68

FlashCORE II M-63

FlashCORE III M-63

Front Cover, removing M-9

**G**

Grounding iii

**I**

I/O Board M-66, M-70

Interconnect Panel M-49

**O**

## Order Form

Basic Spares Kit M-64, M-68

Control Panel Module M-34

Conveyor Belt Module M-26

Cover Tape Module M-24

Covers M-8

Linear Stage Module M-60

NVRAM Battery M-54

Pneumatic Module M-16

PNP head M-44

Programmer Module M-46

Reject Bin M-32

Self-Service Spares Kit M-66, M-70

Tape-In Module M-12

Vacuum Filters M-16

Overview of Components M-4

---

*"I don't see Eyjafjallajökull in here. It should be here."*

Let us know about the items you can't find by e-mailing:

[userdocs@dataio.com](mailto:userdocs@dataio.com).

---

Interface Manifold M-38

**L**

Large Format RoadRunners M-1, M-63

LF, see Large Format

Lower Cover, removing M-9

**M**

Manifold, pneumatic M-16

Modules

- pictured M-4
- replaceable M-3

Motion Controller PCB M-5

**N**

NVRAM battery

- installing M-57
- removing M-55
- reteaching M-58 to M-59

**P**

Pick and Place Head

- aligning M-37
- ordering M-44
- removing M-44 to M-45

*Pick* delay time M-41

Pick Sensor. See End-of-Belt Sensor

Pneumatic Module

- adjusting. See Probe, vacuum sensor.
- reinstalling M-21
- removing M-18

PowerCap Module, see NVRAM battery

Precisor M-72

Probe

- balancing speed M-37
- raising speed M-39
- speed specification M-38
- speed, adjusting M-37
- vacuum sensor, adjusting M-42

Probe Tip, replacing M-65, M-69



Programmer Module  
 alignment M-50  
 alignment tool M-50  
 description M-46  
 reinstalling M-50  
 removing M-47  
 Puff duration M-41

## R

Reject Bin  
 bracket M-33  
 full sensor M-32  
 sensor removal M-33  
 Reteaching Head Positions M-58  
 RoadRunner Models M-63  
 Robot I/O Board M-66, M-70

## S

Safety  
 grounding iii  
 precautions iii  
 Self-Service Spares Kit  
 Large Format M-70  
 Standard RoadRunner M-66  
 Serial Number  
 location M-5  
 Service  
 component overview (figure) M-4  
 replacing assemblies M-1  
 SMT machines supported M-1  
 Socket Adapter M-72  
 wear M-46  
 Spare parts  
 see Basic Spares or Self-Service Spares  
 Spares Kits, models of M-63

## T

Tape-In Module  
 jamming M-12  
 ordering parts M-12  
 Tape-In Module. Also see Adjustable Tape-In  
 Module.  
 Throughput M-37  
 Time Settings M-59  
 Training M-67, M-71  
*Travel* delay time M-41  
 Tube fittings M-19

## V

Vacuum Sensor (Probe), adjusting M-42

## W

Warning, electrical shock M-9  
 Warranty work M-1

## X

XLF M-63



# Sales and Technical Support

## World Wide

Data I/O Corporation  
Redmond, WA USA 98052

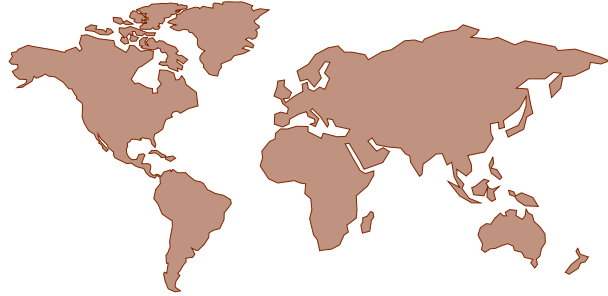

Telephone: inside US 1-800-332-8246  
USA Fax: +1 425-867-6972

---

Contact Data I/O World Wide Support or your local representative. To find your local representative on our Web site, go to <http://www.dataio.com> and click **Contact Us** (upper right), then click **Representative Search** (left side). Then follow the instructions.

**The best way to get support is by using our online form.**

Go to the desired Web site and click the **Technical Support** link or the **Contact Sales** link.



## Optional sales contacts:

[salesDIOAmerica@dataio.com](mailto:salesDIOAmerica@dataio.com)

[ChinaSales@dataio.com](mailto:ChinaSales@dataio.com)

[salesgmbh@data-io.de](mailto:salesgmbh@data-io.de)

---

## When calling or writing, please provide the following information:

- RoadRunner Serial number
- Software Version displayed on the keyboard screen at start-up (turn the power off and then on again)
- Detailed description of the problem you are experiencing (if any)
- Error messages (if any)
- Device manufacturer, part number, package style and number of pins (if device-related)
- Name, telephone number, address and e-mail address

