

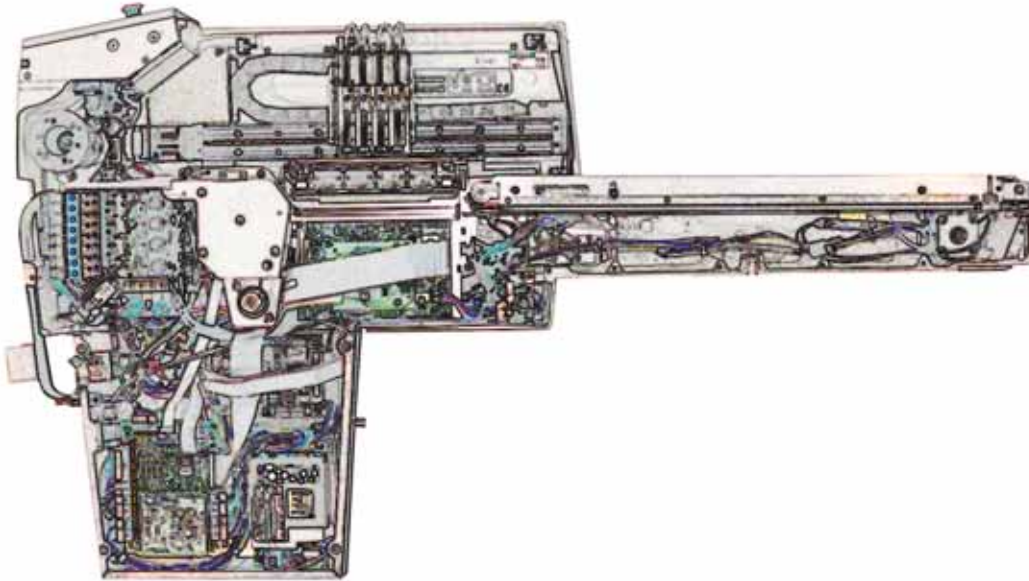

Service



Non-service
information
is in the
**ProLINE-
RoadRunner
Owner's
Manual**

ProLINE-RoadRunner™ Service Manual

for Siemens 80F4, 80F5



PN 096-0251-001

Data I/O has attempted to ensure that the information in this document is accurate and complete. Data I/O assumes no liability for errors, or for any incidental, consequential, indirect, or special damages, including, without limitation, loss of use, loss or alteration of data, delays, or lost profits or savings, arising from the use of this document or the product which it accompanies.

No part of this document may be reproduced or transmitted in any form or by any means, electronic or mechanical, for any purpose, without written permission from Data I/O Corporation. Data I/O order forms may be reproduced for internal use only.

Data I/O is a registered trademark of Data I/O Corporation.

TaskLink is a trademark of Data I/O Corporation.

ProLINE-RoadRunner is a trademark of Data I/O Corporation.

Data I/O Corporation acknowledges the trademarks of other organizations for their respective products or services mentioned in this document.

Data I/O Corporation also acknowledges the RoadRunner team members for their efforts and for supporting the flow of information into this manual.

We are interested in your comments. email: userdocs@dataio.com

© 2004 Data I/O Corporation
All rights reserved

Table of Contents



096-0251-001

For non-service information see the Owner's Manual, 096-0240.

Precautions for Safe Operation iii

Replaceable Modules S-1

Components Overview S-2

Component List S-3

Covers S-4

Removing the Robotics Cover S-5

Removing the PNP Head Cover S-5

Removing the Lower Cover S-5

Removing the Conveyor Dust Cover S-5

Removing the Conveyor Module Cover S-6

Tape-In Module S-8

Removing the Adjustable Tape-In Module S-9

Removing the Standard Tape-In Module S-11

Pneumatic Module S-14

Replacing the Vacuum Filters S-15

Removing the Pneumatic Module S-16

Reinstalling the Pneumatic Module S-18

Cover Tape Module S-20

Removing the Cover Tape Module S-21

Conveyor Module S-22

Removing the Conveyor Module S-23

Adjusting the Conveyor Drive Belt (Notched Only) S-23

Adjusting the End-of-Belt Sensor S-25

Reject Bin S-28

Removing the Reject Bin Full Sensor S-29

Control Panel Module S-30

Removing the Control Panel Module S-31

Pick and Place Head S-33

- Aligning the Head S-33
- Adjusting and Balancing Probe Speed S-33
- Resetting the Pick Delay and Travel Delay Times S-35
- Adjusting Probe Vacuum Sensors S-36
- Adjusting the Probe Position Sensor S-37
- Removing the PNP Head S-38

Programmer Module S-42

- Removing the Programmer Module S-43

Linear Stage Module S-48

- Removing the Linear Stage Module S-49

Basic Spares Kit, Memory RoadRunner S-52

- Replacing the Probe Tips S-53
- Replacing the Air Inlet Tube Assembly S-53
- Replacing the Mounting Hook S-53

Self-Service Spares Kit, Memory RoadRunner S-54

Basic Spares Kit, Microcontroller RoadRunner S-56

- Replacing the Probe Tips S-57
- Replacing the Air Inlet Tube Assembly S-57
- Replacing the Mounting Hook S-57

Self-Service Spares Kit, μ controller RoadRunner S-58

Socket Adapter, Actuator, and Precisor S-60

Alphabetical Index Index-1

Precautions for Safe Operation

The RoadRunner System has been designed for safe and efficient operation. **The system can be dangerous if RoadRunner safety features and precautions in this manual are ignored.**



Electrostatic Discharge

The circuit boards inside RoadRunner are susceptible to electrostatic discharge (ESD), which can damage the circuitry. Also, devices processed through the RoadRunner are very sensitive to static and can be damaged by accidental electrostatic discharge while being handled.

The easiest way to prevent damage from ESD is to make sure a common static potential (ground) exists between static-sensitive devices or components, their environment, and the operator.

Perform all repairs at an ESD-safe workstation.

To avoid possible personal injury or damage to the equipment, please observe the following practices:

- Only **trained personnel** should install, maintain, repair, or troubleshoot this system.
- Do not operate the ProLINE-RoadRunner unless you have been thoroughly trained, and have **read and understand the instructions** in this manual, particularly those that describe the system's safety features.
- Do not use ProLINE-RoadRunner for any application other than its **intended use**.
- Do not operate the system if the **guards or safety devices** are not in their normal operating positions.
- Do not operate RoadRunner with any of the **outer sheet metal panels** removed.
- Do not operate RoadRunner while servicing, replacing, or adjusting any component unless directed to do so in this manual. Make sure that the RoadRunner is **properly shut down** before performing any of these operations.
- Do not place any part of your body near or in the direct path of **moving parts**.
- **Do not disable** or attempt to defeat any of the protective safety features of this system. Personal injury or equipment damage can occur if any safety systems on RoadRunner are disabled. If you suspect that a safety feature of the RoadRunner is damaged or malfunctioning, stop using the RoadRunner immediately and contact Data I/O Customer Service or a local Data I/O approved service representative.
- Use extra caution when working around the RoadRunner's Output Belt. RoadRunner's safety shields do not cover or fully enclose the **output conveyor**. It is possible that an operator's hands, other body parts, or loose clothing can get caught or pinched in it.
- Wearing **hearing protection** is recommended while operating the RoadRunner. Sound pressure levels may exceed 85 decibels.
- Shut off the **pressurized air** or disconnect the air hose before servicing pneumatic parts.





Service—Siemens

Many modules and components on the RoadRunner are designed to be serviced or replaced by qualified technicians. You may wish to keep backup modules or components for replacements. The removed module may be sent to Data I/O for adjustment, repairs, or replacement.

Replaceable Modules

Replaceable modules include:

- Tape-In Module
- Conveyor Module
- Control Panel Module
- Linear Stage Module (with PNP Head)
- Pneumatic Module
- Cover Tape Module
- PNP Head (subassembly)
- Programmer Module

Some components can be replaced or adjusted at the customer location. Replacement and adjustment procedures for those components are included in this chapter. Some modules can be removed and sent to Data I/O or a local representative for servicing or exchanging.

Within each main section of this chapter is an order form with relevant Model Names. These names represent the RoadRunner configuration at the time of printing this manual only and may differ from your unit. However, these Model Names correspond to the latest interchangeable replacement.



Tools required for RoadRunner maintenance are listed in “Tools Required” in Chapter 5 of the Owner’s Manual.

Some of the tools required are • Metric hex keys (Allen wrenches), • inch hex keys, • a volt meter or multi-meter, • and a metric scale or calipers.

CAUTION:  *Electrostatic discharge may damage parts. Before repair work begins, place the RoadRunner on an ESD-safe workstation.*

Components Overview

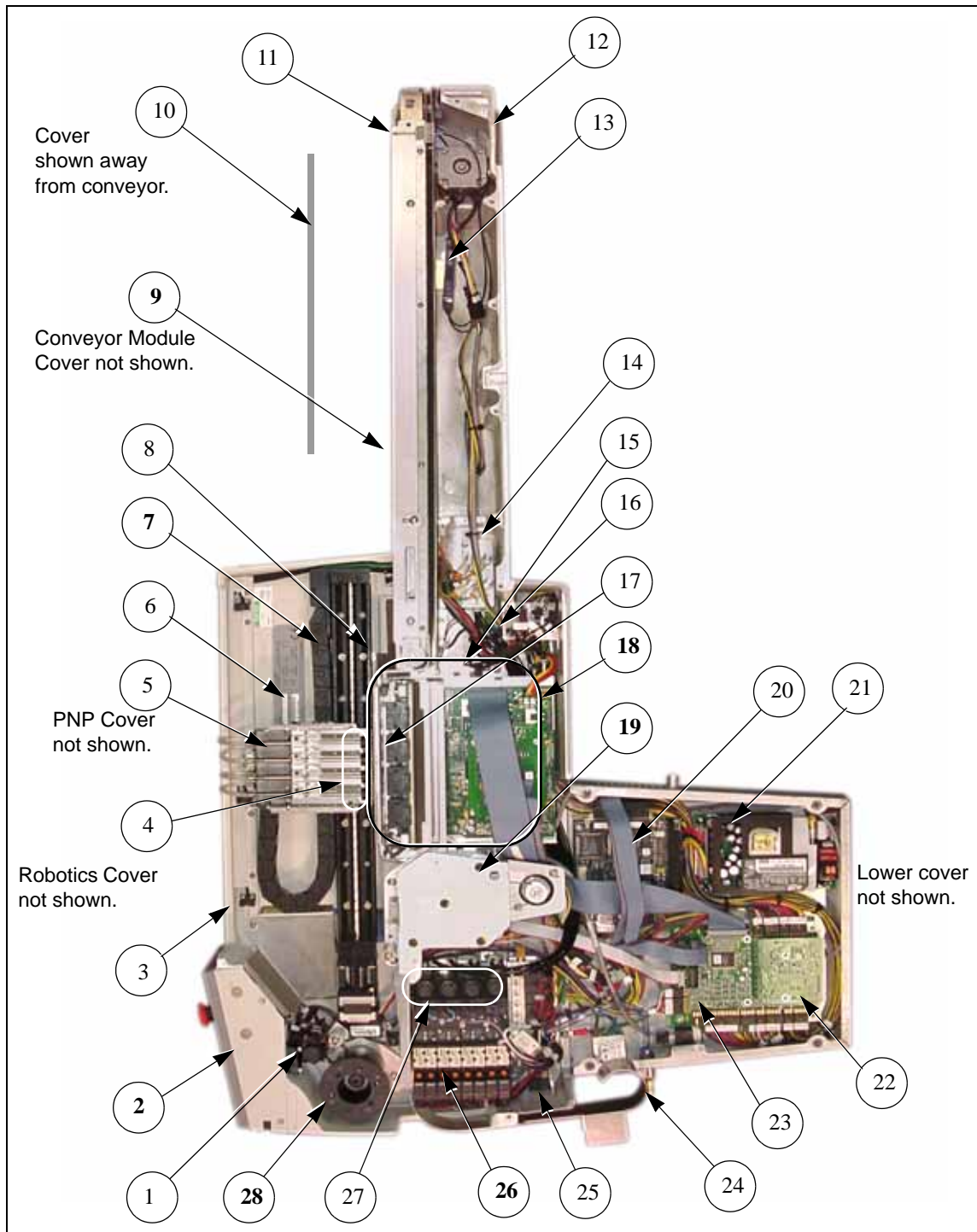

Figure S-1—Component Overview

CAUTION: Place RoadRunner on an ESD-safe workstation.
CAUTION: To prevent damage when unplugging cables, pull the connector and not the wires.

Component List

(Modules are listed in bold type)

1. Robotics-Cover-Open Sensor
2. **Control Panel Module**, [page S-30](#)
3. Head Limit Sensors
4. Rubber Probe Tips
5. Pick and Place (PNP) Head
6. Serial Number Label
7. **Linear Stage Module**, [page S-48](#)
8. Reject Bin
9. **Conveyor Module**, [page S-22](#)
10. Conveyor Dust Cover
11. End-Of-Belt Sensor Optic
12. Dowel-alignment Teeth
13. End-Of-Belt Sensor Controller
14. Interface Manifold
15. Socket Actuator Sensor
16. Interconnect panel
17. Socket Adapter
18. **Programmer Module**, [page S-42](#)
19. **Tape-In Module**, [page S-8](#)
20. Motion Controller Board
21. Power Supply
22. SMT Communications Board
23. Robot I/O Board
24. Air inlet connection
25. Power Switch
26. **Pneumatic Module**, [page S-14](#)
27. Air Filters
28. **Cover Tape Module**, [page S-20](#)



CAUTION: *Electrostatic discharge may damage parts. Before repair work begins, place the RoadRunner on an ESD-safe workstation.*

Covers

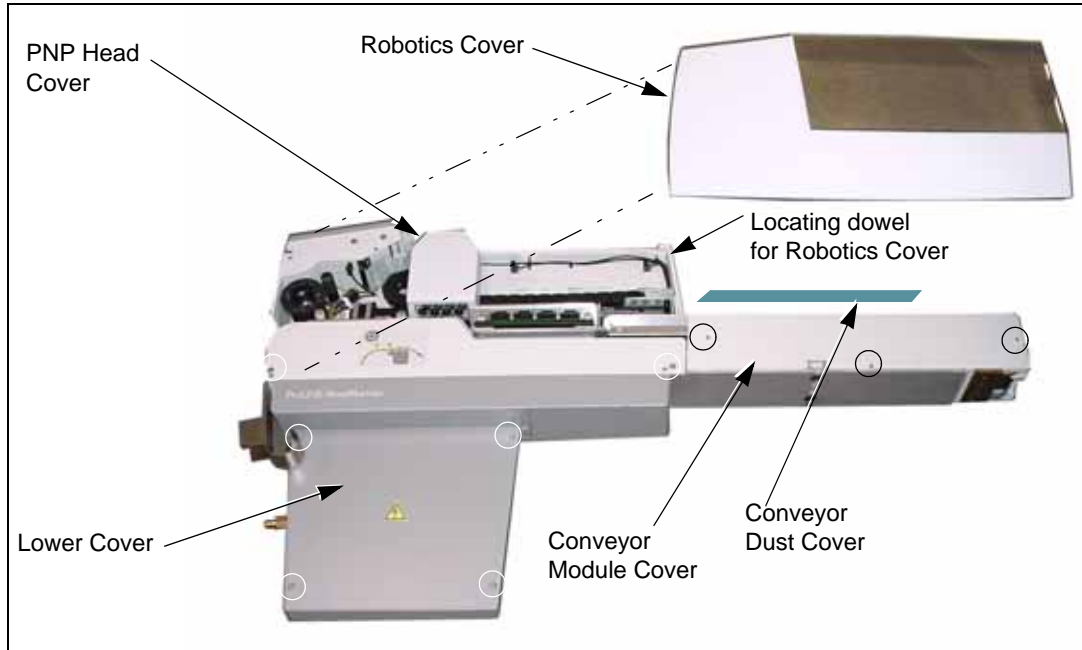

Figure S-2—Cover Screw Locations Indicated by Circles

The RoadRunner has five removable covers:

- Robotics Cover
- PNP Head Cover
- Lower Cover
- Conveyor Dust Cover
- Conveyor Module Cover

The Robotics Cover, made of semi-transparent plastic, shields the tape path and the programmer.

Data I/O Parts Ordering Information

Instructions: 1. Copy this page. 2. Fill in your RoadRunner model and serial numbers (see the label on the chassis under the Robotics Cover). 3. Fill in the quantity for the item(s) desired. 4. Call Data I/O, or visit our Web site, for part prices (optional). 5. Mail or FAX it with your purchase order to Data I/O. See the last page of this manual for contact information.

ProLINE-RoadRunner Model No. _____ Serial No. _____

Model Name	Description	Qty	Price Ea.	Totals
RR-ROBOTICS COVER-SIEMENS	Robotics Cover		\$	\$
COVER PNP HEAD	PNP Head Cover		\$	\$
COVER, HOUSING	Lower Cover		\$	\$
RR-COVER DUST-S	Conveyor Dust Cover		\$	\$
RR-COVER CONVEYOR-S	Conveyor Module Cover		\$	\$
			\$	\$

Signature: _____ Date: _____ Company: _____

Removing the Robotics Cover

Grasp the outer edges of the Robotics Cover and gently pull away from the Control Panel and out.

There is a locating dowel pin on the end opposite the Control Panel Module.

NOTE: The Robotics Cover can be removed while the RoadRunner is running. However, the robot speed reduces by 50%.

WARNING

Shock Warning. Do not remove the Lower Cover or the Conveyor Module Cover while the RoadRunner is plugged in.

Removing the PNP Head Cover

The PNP Head Cover is magnetically attached to the head and pulls off.

To replace it, set it over the head and rock it until the metal ridges on the inside of the cover seat into notches on the head.

Removing the Lower Cover

1. Turn the power off.
2. Disconnect the RoadRunner power cord and air supply.

NOTE: The RoadRunner pressurized air supply tube has a quick disconnect fitting with an automatic shut off. The line may be disconnected without shutting off the supply line air pressure.



For screw locations see [Figure S-2](#).

3. Remove the Robotics Cover.
4. Remove the screws that hold the Lower Cover to the chassis. For screw locations see [Figure S-2](#).

Removing the Conveyor Dust Cover

The Conveyor Dust Cover lifts off two dowel pins.

Removing the Conveyor Module Cover

1. Turn the power off.
2. Unplug the RoadRunner.
3. Remove the screws that hold the Conveyor Module Cover to the chassis. See [Figure S-2](#). The number of screws varies depending on model.

S

S

Blank page.

S

S

Tape-In Module

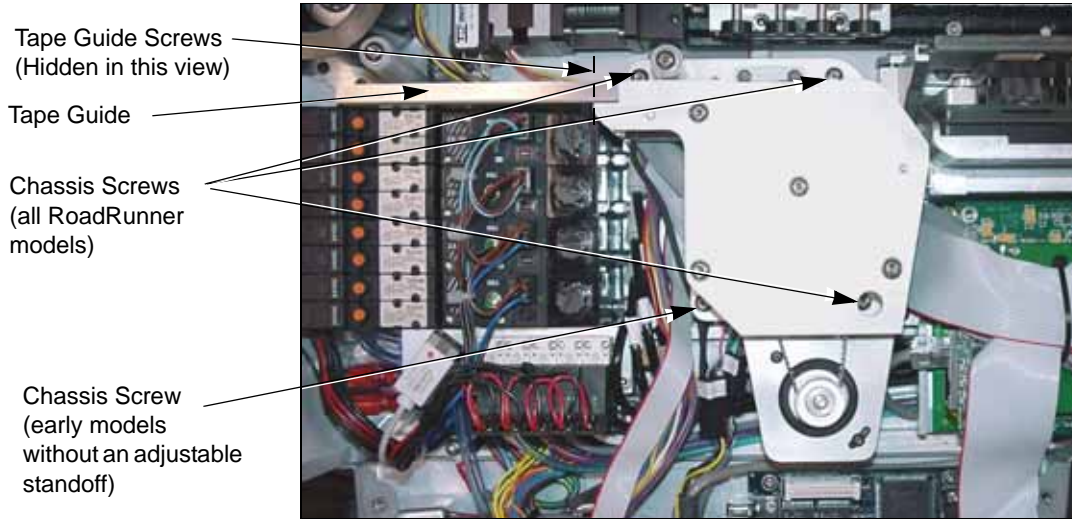

Figure S-3—Location of Tape-In Module Screws

The Tape-In Module uses sensors to determine if the cover tape is present or broken, and sends feedback to the system controller. The Tape-In Module's aluminum housing is mounted on the chassis and guides the device tape.

If the device tape is jamming in the sprocket or tape path, there could be a problem with the Tape-In Module. Refer to the Troubleshooting chapter to identify the problem. If the problem is the Tape-In Module, remove it and return it to Data I/O for repair or replacement. If your RoadRunner is past warranty period, you may elect to repair it on-site if you have a certified technician.

Two sensors on the far side of this module can be replaced individually.

An Adjustable Tape-In Module is also available.

Data I/O Parts Ordering Information

Instructions: 1. Copy this page. 2. Fill in your RoadRunner model and serial numbers (see the label on the chassis under the Robotics Cover). 3. Fill in the quantity for the item(s) desired. 4. Call Data I/O, or visit our Web site, for part prices (optional). 5. Mail or FAX it with your purchase order to Data I/O. See the last page of this manual for contact information.

ProLINE-RoadRunner Model No. _____ Serial No. _____

Model Name	Description	Qty	Price Ea.	Totals
16MM TAPEIN KIT	Kit, Tape-In Module, 16mm		\$	\$
24MM TAPEIN KIT	Kit, Tape-In Module, 24mm		\$	\$
32MM TAPEIN KIT	Kit, Tape-In Module, 32mm		\$	\$
RR-ADJUSTABLE TAPE-IN KIT	Kit, Adjustable Tape-In Module		\$	\$
SLOT SENSOR CAB	Tape Advance Sensor (Cable Assy)		\$	\$
SLOT SENSOR CAB	Cover Tape Broken Sensor (Cable Assy)		\$	\$
ASSY,TAPE IN,RR-uC	Kit, Tape-In Module, Microcontroller		\$	\$

Signature: _____ Date: _____ Company: _____

Removing the Adjustable Tape-In Module

(For the Standard Tape-In Module, see [page S-11](#).)

1. Turn the power off.
2. Disconnect the RoadRunner power cord and air supply.
3. Remove the Robotics Cover and Lower Cover.
4. Remove the two screws attaching the Tape Guide to the Adjustable Tape-In (ATI) Module.



See “Covers” on page S-4.

For screw locations see Figure S-3.

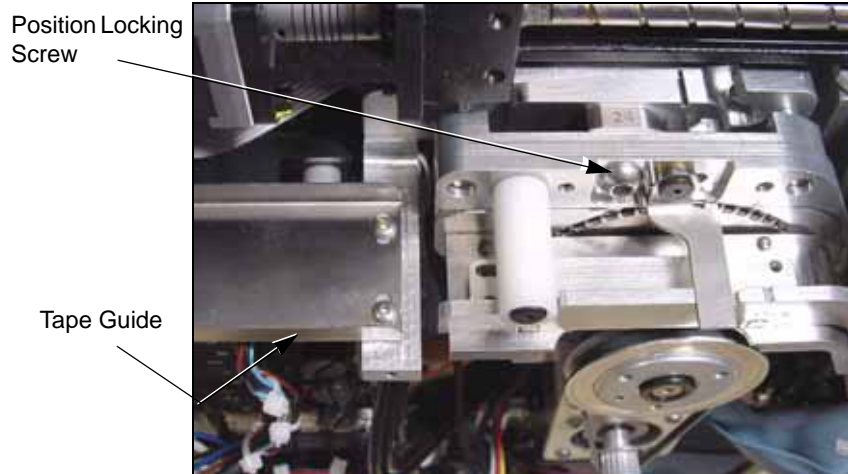

Figure S-4—The Adjustable Tape-In Module

5. Unscrew the Position Locking Screw and lift the subassembly away from the Base as far as the wires allow.
6. Check that wire labels are clearly marked and unplug the wires for the Tape Advance Sensor, the Cover Tape Broken Sensor, and the Tape-In Motor.

NOTE: The two sensors are the same—where they plug in determines their function.

The sensors may be replaced independently of the module.

7. Remove the three screws that attach the ATI Base to the chassis. See the figure below.



Figure S-5—Adjustable Tape-In Module Base

8. Lift the Base from the chassis.

Replacement is in the reverse order of removal with these precautions:

- Ensure that cable connectors are mated correctly.
- Ensure that no wires or hoses get pinched.
- If you are installing a Tape-In Module other than the one you removed, you need to align it to the PNP Head by performing the alignment procedure. (See next heading.)

Aligning the Adjustable Tape-In Module

To center the tape path under the PNP probes:

1. Load a piece of empty device tape into the Adjustable Tape-In (ATI) Module.
2. Move the PNP Head so that Probe 1 is directly over the pick point.
3. Remove the PNP Head Cover by pulling it off.
4. Remove the rubber Probe Tip from Probe 1.
5. Extend Probe 1 fully by pushing down on the block below the spring to visually compare the position of the hole in the center of the tape pocket to the probe.



To lower the probe, push probe here with finger.

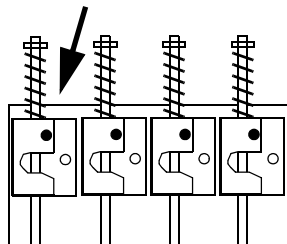

If the probe is centered over the hole, then the tape path is centered. Replace the Probe tip; you are done centering the tape path. Otherwise continue.

6. Loosen the Position Locking Screw.

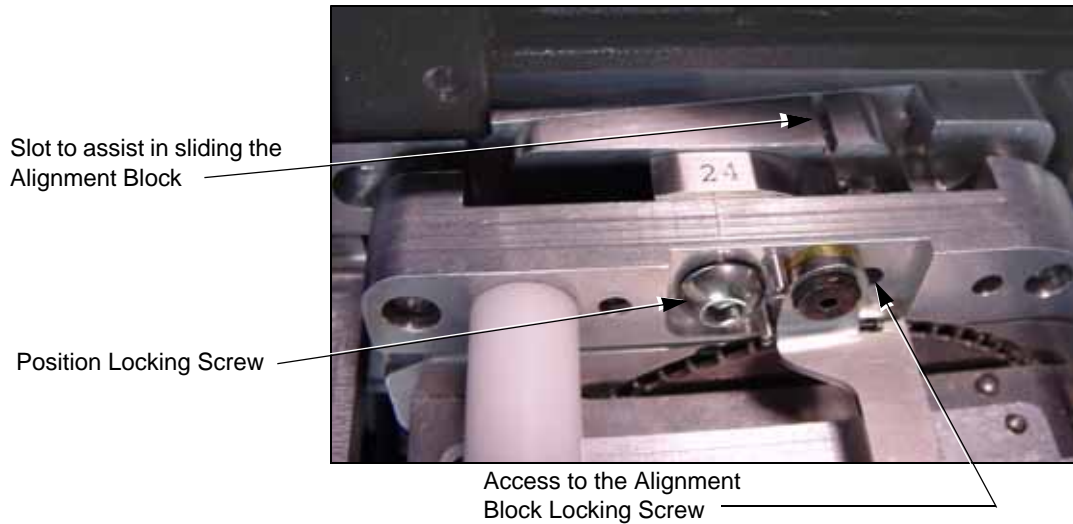

Figure S-6—Aligning the Adjustable Tape-In Module

7. Loosen the Alignment Block Locking Screw with a 2 mm Allen Wrench. A small access hole is provided.
8. Slide the Alignment Block left or right as needed to bring the device tape in-line with the probe. A slot in the top of the Alignment Block accommodates a flat screwdriver to assist in sliding the block.
9. Tighten the Position Locking Screw.
10. Recheck alignment.
11. Tighten the Alignment Block Locking Screw.
12. Replace the Probe Tip.
13. Replace the PNP Head Cover.

Removing the Standard Tape-In Module



See “Covers” on page S-4.

For screw locations see Figure S-3.

1. Turn the power off.
2. Disconnect the RoadRunner power cord and air supply.
3. Remove the Robotics Cover and Lower Cover.
4. Remove the two screws attaching the Tape Guide Bracket to the Tape-In Module.
5. Remove the three or four screws (depending on your model) that connect the Tape-In Module to the chassis.
6. Lift the Tape-In Module from the chassis as far as wires will allow.

NOTE: The 16mm and 24mm Tape-In Modules have spacers that could fall out. They must be saved and reused on reinstallation.

7. Check that wire labels are clearly marked and unplug the wires for the Tape Advance Sensor, the Cover Tape Broken Sensor, and the Tape-In Motor.

The sensors may be replaced independently of the module.

NOTE: The two sensors are the same—where they plug in determines their function.

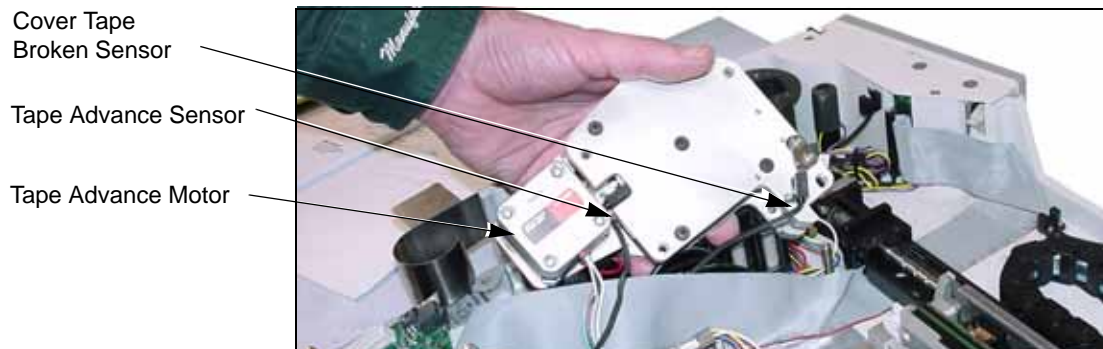

Figure S-7—Location of Sensors and Motor on the Tape-In Module

- 7a. To replace the Tape Advance Sensor or the Cover Tape Broken Sensor, remove the screw attaching the sensor to the module. (The cables have been unplugged from the connector in a previous step.)

Replacement is in the reverse order of removal with these precautions:

- Ensure that cable connectors are mated correctly.
- Ensure that no wires or hoses get pinched.
- Ensure that the Module seats on the standoffs (and spacers—16mm and 24mm Modules).
- If you are installing a Tape-In Module different from the one you removed, you need to align it to the PNP Head by performing the alignment procedure. (See following heading.)

Aligning the Standard Tape-In Module

Some Tape-In Modules are not adjustable. Others are mounted on an adjustable Standoff for alignment purposes. If your model has the Adjustable Standoff, you will see the adjustment stud from the top as you look down at the Tape-In Module as shown in the figure below.



Figure S-8—Some Tape-In Modules have an Adjustable Standoff for setting the Alignment with the Probes. The wrench flats and Locknut identify the Adjustment Stud from a non-adjustable Standoff.

To align the Tape-In Module:

1. Loosen the top left and bottom right mounting screws.
2. Loosen the Locknut on the Adjustable Standoff (7 mm wrench).

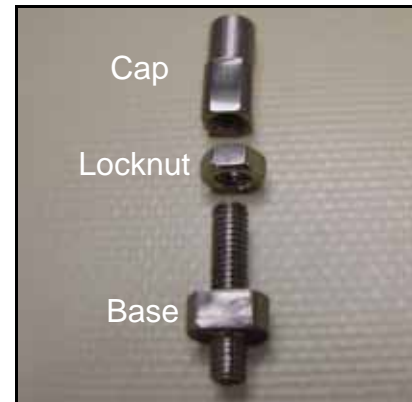

Figure S-9—Adjustable Stud for the Standard Tape-In Module

3. Adjust the Cap of the Adjustable Standoff (6 mm wrench) until the Tape-In Module is in-line with a PNP Probe. To do that:
 - 3a. Place a small piece of device tape on the Tape-In Module.
 - 3b. Remove the rubber tip from Probe 1.
 - 3c. Extend Probe 1 fully by pushing down on the block below the spring.
 - 3d. Adjust the Standoff to visually align the hole in the center of the tape pocket with the probe.
4. Screw the Locknut until it rests tight against the Cap to lock it in place.
5. Tighten the other two mounting screws.
6. Recheck alignment; loosen the Locknut and readjust if necessary.
7. Put the rubber tip back onto Probe 1.

Pneumatic Module

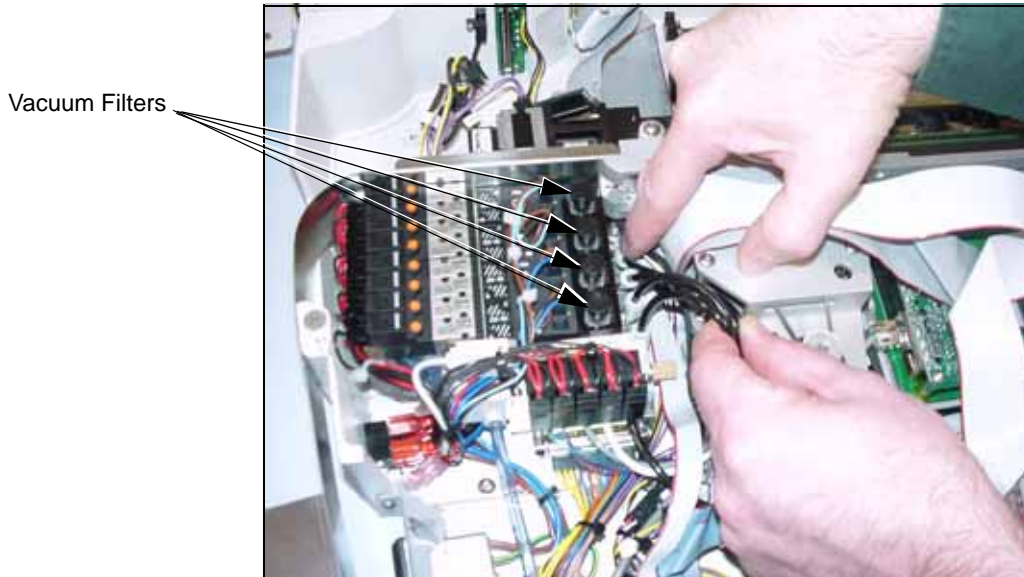

Figure S-10—Location of the Vacuum Filters

The pneumatic valve block controls vacuum and blowoff air to the probes, as well as pressurized air to the probe cylinders and programmer socket cylinders. The valve block and vacuum manifold are a one piece unit.

Air pressure is affected by clogged or dirty filters or hoses, and by improper connections. If the vacuum filters are clogged or dirty, vacuum sensors have difficulty detecting whether a device is on the probe or not. This can result in error messages such as “Device pick failure at input with probe 1.”

Data I/O Parts Ordering Information

Instructions: 1. Copy this page. 2. Fill in your RoadRunner model and serial numbers (see the label on the chassis under the Robotics Cover). 3. Fill in the quantity for the item(s) desired. 4. Call Data I/O, or visit our Web site, for part prices (optional). 5. Mail or FAX it with your purchase order to Data I/O. See the last page of this manual for contact information.

ProLINE-RoadRunner Model No. _____ Serial No. _____

Model Name	Description	Qty	Price Ea.	Totals
VAC FILTER	Vacuum filter		\$	\$
ASSY,PNEUMATIC,MODULE	Pneumatic Module		\$	\$
			\$	\$
			\$	\$
			\$	\$

Signature: _____ Date: _____ Company: _____

S

S

If you experience problems such as dropped devices or pick failures, replace the vacuum filters (page S-15), adjust the vacuum sensor (page S-36), or see the chapter on “Troubleshooting” in the Owner’s Manual.

NOTE: In normal low-dust conditions, Vacuum Filters must be replaced every 6 months. Replacement may need to be done more frequently in dustier environments.

Replacing the Vacuum Filters



See “Covers” on page S-4.

1. Turn the power off.
2. Disconnect the RoadRunner power cord and air supply.
3. Remove the Robotics and Lower Covers.
4. Remove the square plastic housings with the Vacuum Filters by unscrewing the thumbscrews from the valve block.

NOTE: Ensure that the gasket between the housing and the valve block does not fall out during removal or installation of the housing. If it does, install the gasket into the groove on the valve block.

CAUTION: The housing has two locating pins. To prevent damage, orient the housing correctly when reinstalling.



Figure S-11—Vacuum Filter Components

5. Remove the filter from the plastic housing.
6. When installing a new filter, make sure the rubber gasket is in place between the housing and the valve block.

Removing the Pneumatic Module

1. Turn the power off.
2. Disconnect the RoadRunner power cord and air supply.
The RoadRunner pressurized air supply tube has a quick disconnect fitting with an automatic shut off. The line may be disconnected without shutting off the supply line air pressure.
3. Pull off the Robotics Cover.
4. Remove the Lower Cover.
5. Remove the Tape Guide by removing four screws.



For more information, see
“Removing the Lower
Cover” on page S-5.

NOTE: The vacuum lines and air pressure lines must be reinstalled to their same locations. Do not reverse them. Ensure that each line has a label before disconnecting.

6. Disconnect the four vacuum lines on the side of the manifold.
To release the “One-touch” connector, push the connector sleeve and pull the tube simultaneously. To reconnect, simply insert the tube into the housing sleeve, pushing it all the way in.

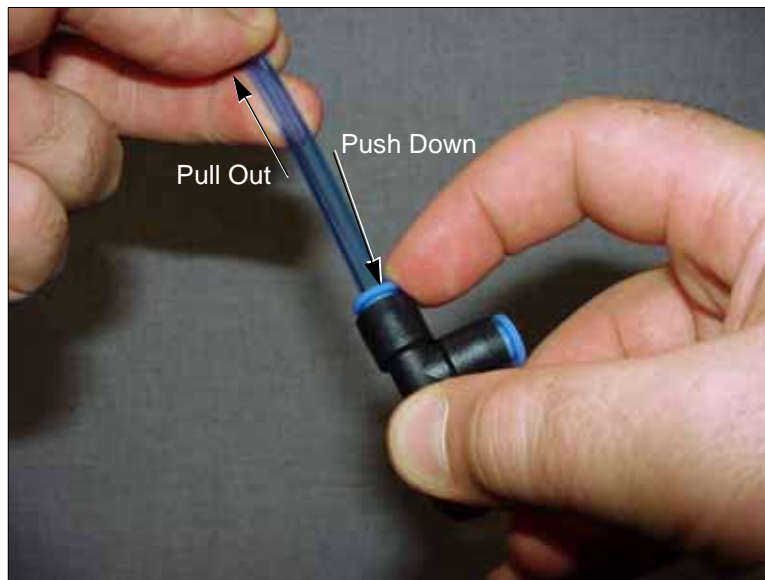

Figure S-12—Disconnecting a Pneumatic Tube from the One-touch Connector

7. Disconnect the Actuator Air Line and the four Probe Air Pressure Lines near the 25-pin connector. (All use One-touch connectors.)

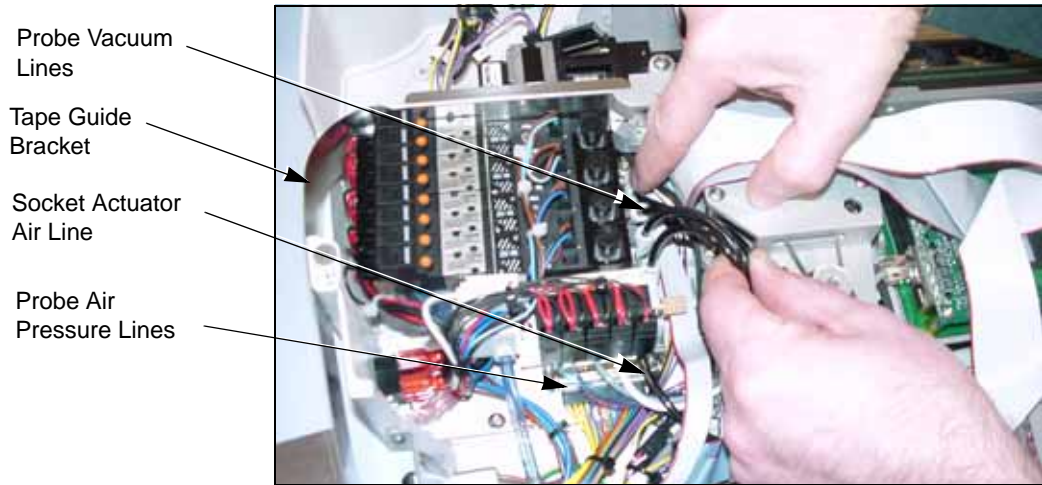

Figure S-13—Location of Vacuum and Air Lines

8. Disconnect the Pneumatic Manifold Supply Line at the One-touch connector on the manifold.
9. Unscrew the two screws from the 25-pin cable connector and unplug the connector from the manifold bracket.

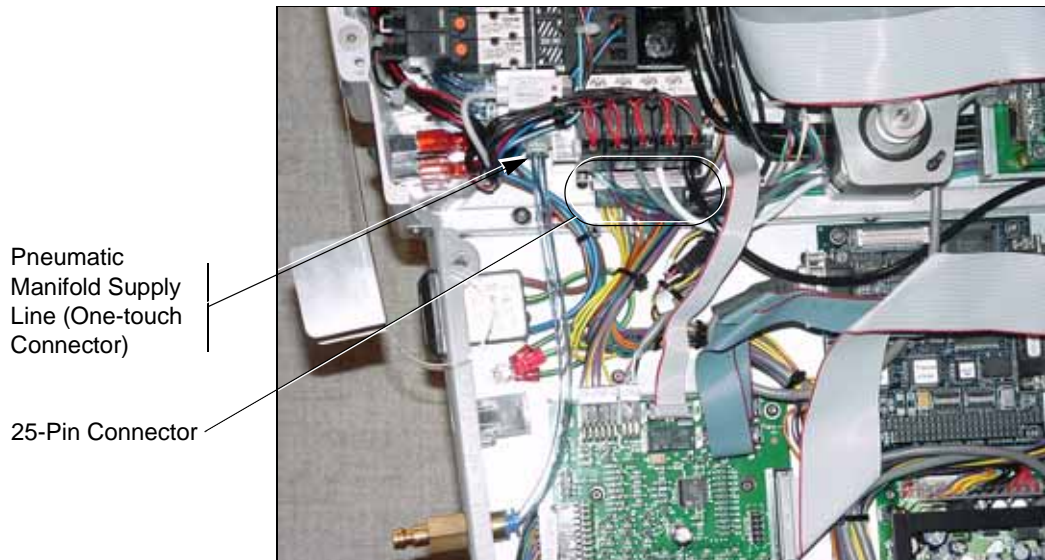

Figure S-14—Location of the Vacuum Manifold Main Air Line and Wiring Connector

10. Remove the three screws securing the Pneumatic Module to the RoadRunner chassis.

S

S

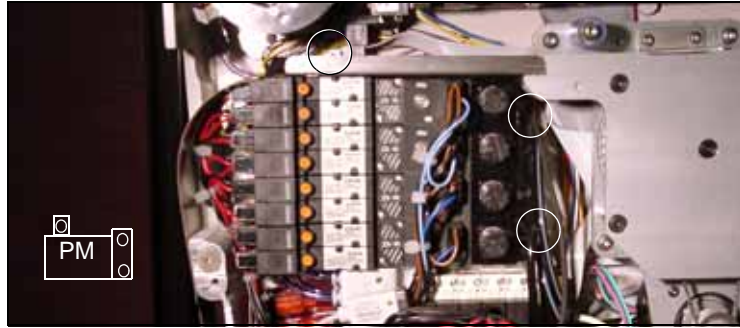

Figure S-15—Pneumatic Module fastener locations.

11. Lift the Pneumatic Module free of the RoadRunner chassis.

Reinstalling the Pneumatic Module

Installation is done in the reverse order of removal, then the following post-installation adjustments are required:

1. At the Control Panel, verify proper electrical and pneumatic connections as follows:
 - 1a. Extend and retract each probe to verify correct plumbing. *Robot Diagnostics » Probe X » Position » Arrow Up/Down.*
 - 1b. Enable vacuum to each probe to verify correct plumbing. *Robot Diagnostics » Probe X » Vac Sense » Arrow Up/Down.*
 - 1c. Enable probe “Puff” and verify correct switching of positive air pressure at the probe tips. *Robot Diagnostics » Probe 1 » Puff » Up/Down Arrow.*
2. Adjust the probe vacuum sensors.
3. Adjust probe speed.



For step 2 see “[Adjusting Probe Vacuum Sensors](#)” on page S-36.

For step 3 see “[Adjusting and Balancing Probe Speed](#)” on page S-33.

Blank Page

S

S

Cover Tape Module



Figure S-16—Cover Tape Tensioning the Tape Broken Sensor

If the Cover Tape Module fails to wind tape onto the reel, first check to see if the reel is full. Also, check that there is tension against the Tape Broken Sensor.

If the Take-Up Reel is not full but the module is not winding tape, then the Cover Tape Module is suspect. Check for

- loose or broken drive belt
- loose reel not seated on the hub pins
- malfunctioning motor
- malfunctioning clutch assembly, or
- a motor connector that is loose or disconnected.

If the problem is the motor or drive belt, then the Cover Tape Module needs to be removed and returned to Data I/O for repair. If your RoadRunner is past warranty period, you may elect to repair it on-site if you have a certified technician.

Data I/O Parts Ordering Information

Instructions: 1. Copy this page. 2. Fill in your RoadRunner model and serial numbers (see the label on the chassis under the Robotics Cover). 3. Fill in the quantity for the item(s) desired. 4. Call Data I/O, or visit our Web site, for part prices (optional). 5. Mail or FAX it with your purchase order to Data I/O. See the last page of this manual for contact information.

ProLINE-RoadRunner Model No. _____ Serial No. _____

Model Name	Description	Qty	Price Ea.	Totals
RR-COVER TAPE MOD	Cover Tape Module		\$	\$
			\$	\$
			\$	\$
			\$	\$
			\$	\$
			\$	\$

Signature: _____ Date: _____ Company: _____

S

S

Removing the Cover Tape Module

1. Turn the power off.
2. Unplug the RoadRunner power cord.
3. Remove the Robotics Cover.
4. Remove the tape reel from the Cover Tape Module.
5. Remove the three screws that mount the Cover Tape Module to the RoadRunner chassis.

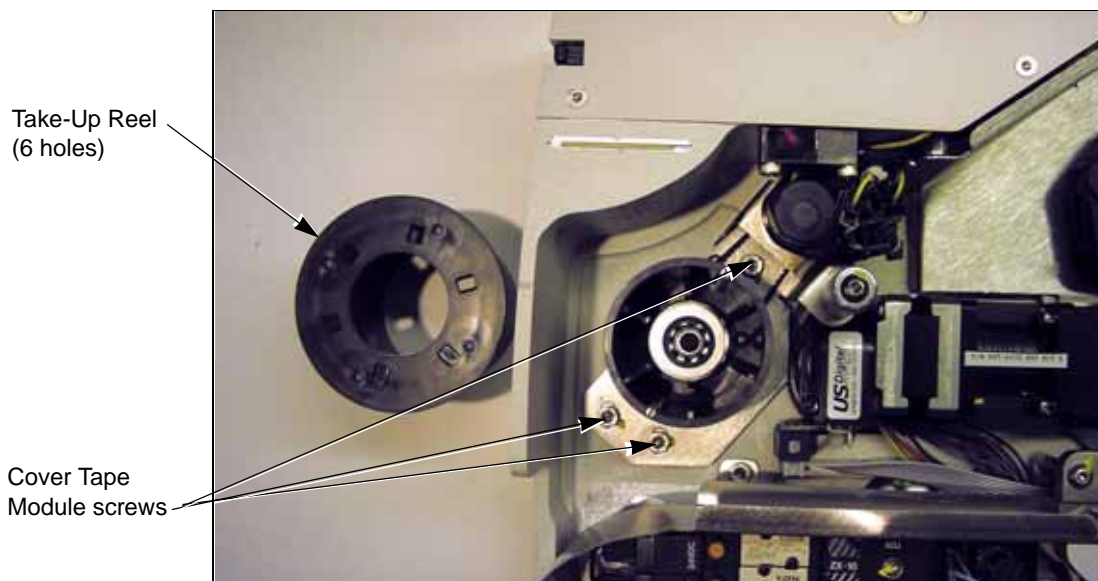

Figure S-17—Location of the Cover Tape Module Mounting Screws (with the Reel Removed)

6. Disconnect the cable from the Cover Tape Module motor.

Replacement of the Cover Tape Module is done in reverse order of removal.

NOTE: There are two styles of Take-Up Reel. One has six holes (shown) and snaps onto the hub, the other has two slots that you fit over pins on the hub and twist into place. Use only the Take-Up Reel appropriate for your hub.

Conveyor Module

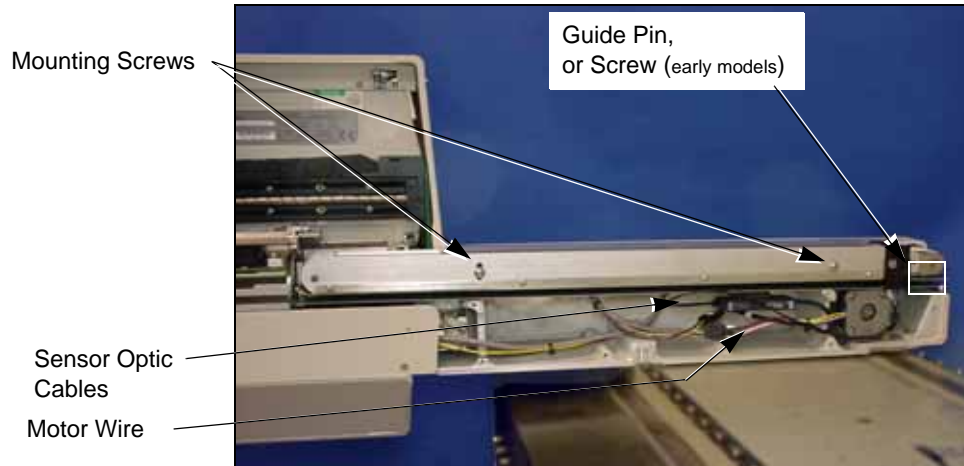

Figure S-18—Location of Wires and Screws on the Conveyor Module

The conveyor belt, the belt motor, and the End-of-Belt Sensor make up the main parts of the Conveyor Module. The device tape path is also part of the assembly.

If the conveyor belt becomes creased, it will cause parts placed on the crease to be mispositioned. For this reason, a Conveyor Module with a creased or damaged belt should be immediately replaced.

The entire Conveyor Module can be removed and replaced or sent to Data I/O for repair. If your RoadRunner is past warranty period, you may elect to repair it on-site if you have a certified technician.

The End-of-Belt sensor optic can be adjusted and the sensor controller retight.

Data I/O Parts Ordering Information

Instructions: 1. Copy this page. 2. Fill in your RoadRunner model and serial numbers (see the label on the chassis under the Robotics Cover). 3. Fill in the quantity for the item(s) desired. 4. Call Data I/O, or visit our Web site, for part prices (optional). 5. Mail or FAX it with your purchase order to Data I/O. See the last page of this manual for contact information.

ProLINE-RoadRunner Model No. _____ Serial No. _____

Model Name	Description	Qty	Price Ea.	Totals
RR-ASSY CONV, SIEMENS	Conveyor Module		\$	\$
ASSY,CONVEYOR 16MM, SIEMENS,RR-uC	Conveyor Module, Microcontroller		\$	\$
			\$	\$

Signature: _____ Date: _____ Company: _____

Removing the Conveyor Module



For more information, see “Removing the Conveyor Module Cover” on page S-6.

1. Turn the power off.
2. Disconnect the RoadRunner power cord and air supply.
3. Lift off the Conveyor Dust Cover.
4. Remove the Conveyor Module Cover.
5. Cut the tie wraps securing the wires for the belt motor and the sensors.

CAUTION: Optic cables are fragile and may break. Do not bend radically.



For Conveyor screw locations see Figure S-18.

6. Disconnect two connectors: one with wires from the belt motor and one from the sensor controller.
7. Remove two screws on the face of the Conveyor Module housing, and on early models, one screw through the tape path guide.
8. Lift the Conveyor Module free of the RoadRunner chassis.

Reinstalling the Conveyor Module

To reinstall the conveyor, reverse the removal steps, plus perform the following:

1. Notice the locating pin on the chassis for location.
2. Set the conveyor height as follows:
 - 2a. With the RoadRunner in its normal upright position and the conveyor fasteners in but not tightened, move the PNP Head over the conveyor belt.
 - 2b. Place your thinnest device on the belt below Probe 1.
 - 2c. Lower Probe 1 fully (pushing on the block below the spring). Adjust the conveyor height so that the probe tip just barely contacts the device on the belt, then tighten the fasteners.
 - 2d. Recheck the height after tightening the fasteners.

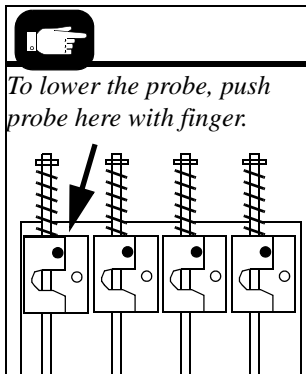

Adjusting the Conveyor Drive Belt (Notched Only)

Your RoadRunner model may have a conveyor with a smooth pulley or a notched pulley. The drive belt never needs adjusting on models with the smooth pulley.

See Figure S-19 to determine which pulley your model has.

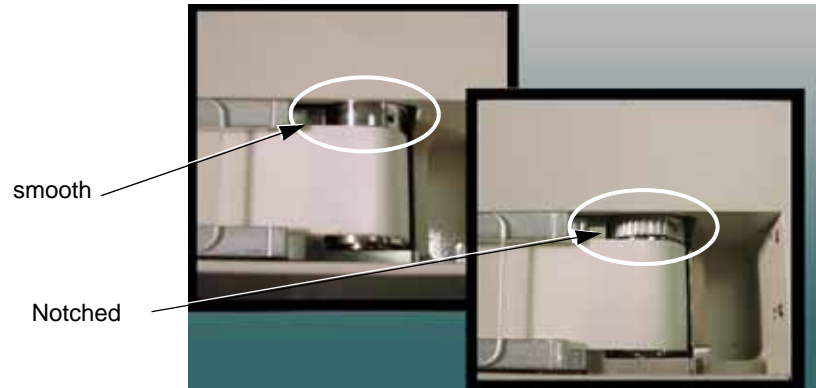

Figure S-19—Visually inspect the Conveyor to determine if you have a notched pulley.



For more information, see “Removing the Conveyor Module” on page S-23.

A metric scale or calipers is required.

1. Remove the Conveyor Module.
2. Pinch the Conveyor Motor Drive Belt midway between the pulleys and measure the distance between the belts at the pinched area, measuring to the outside edge of the belts. The distance should be $10\text{mm} \pm 1\text{mm}$.

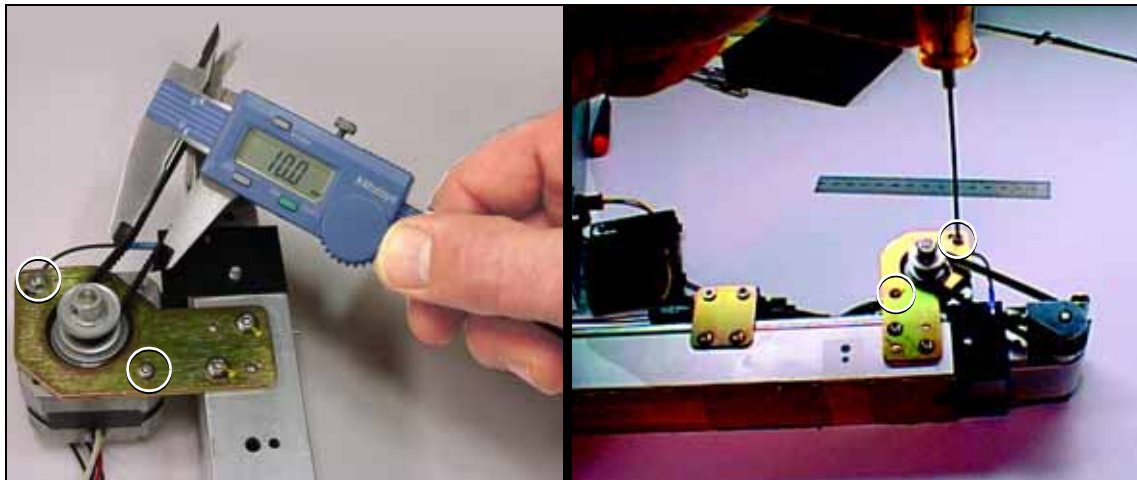

Figure S-20—Checking Belt Tension and Loosening the Drive Motor Screws for Belt Adjustment



For information on reinstalling the conveyor see page S-23.

3. If the belt tension is not within tolerance, loosen the two mounting screws attaching the Conveyor Drive Motor to the mounting bracket, and adjust the motor position. Retighten the screws.
4. Recheck the pinched belt dimension.
5. When the belt tension is correctly adjusted, replace the Conveyor Module and test for device rotation.

S

S

Adjusting the End-of-Belt Sensor

The End-of-Belt Sensor Optic stops the conveyor when parts reach the pick point. The optic functions by sending a beam across the pick point between two fiber optic cables. When a device breaks the beam, the End-of-Belt Optic stops the belt. The most likely indication that the End-of-Belt Optic is out of adjustment or broken, is that parts fall off the end of the conveyor.

If devices are falling off the end of the conveyor, first test to make sure the sensor controller is functioning (see below). If the sensor is functioning, but parts are still passing the pick point, reattach the sensor controller.

Testing the End-of-Belt Sensor

1. From the top level menu select *Robot Diagnostics*.
2. Select *Belt*.
3. Select *Pick Sensor*.
4. Put your finger at the SMT pick point to block the sensor optic.
5. The Control Panel display will show *Pick Sensor: 1* whenever your finger is blocking the beam, and *Pick Sensor: 0* when not blocked.

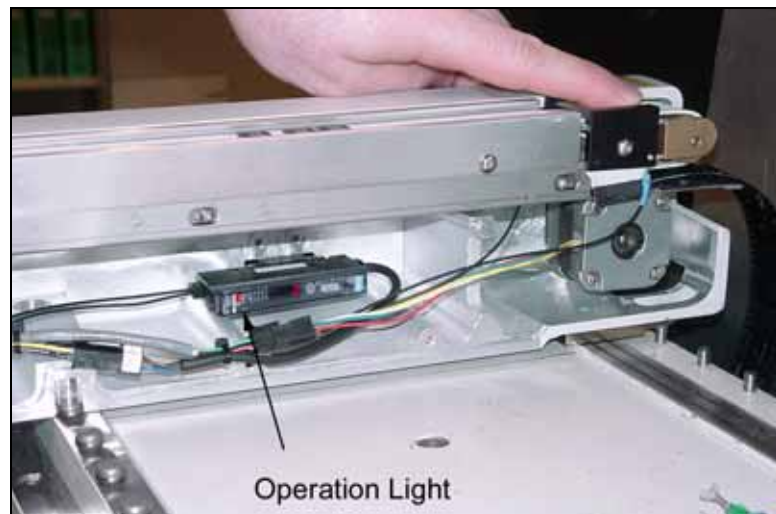

Figure S-21—Testing the End-of-Belt Sensor (The Conveyor Cover need not be removed.)

6. If *Pick Sensor: 1* is not displayed when the beam is blocked, check to make sure that all the sensor wires and fiber optics are connected properly.
 - 6a. If *Pick Sensor: 1* still does not display, then the Conveyor Module needs to be replaced.
 - 6b. If *Pick Sensor: 1* does display, see “Reteaching the End-of-Belt Sensor Controller,” below.

Reteaching the End-of-Belt Sensor Controller

1. Lift off the Conveyor Dust Cover.
2. Remove the Conveyor Module Cover.
3. Press the Emergency Stop button—the conveyor belt can now be rotated by hand.
4. Clean the conveyor belt. With isopropyl alcohol on a lint-free cloth, clean the exposed portion of the belt and then dry it. Rotate the belt and repeat.
5. Manually rotate the belt so that the sensor controller displays its highest value.
6. Place a device on the SMT pick point so it blocks the optic beam.
7. Push *Set* on the sensor controller.



The controller is mounted to the chassis under the Conveyor Module.

End-of-Belt
Optic
Sensor (Beam)

End-of-Belt
Sensor
Controller

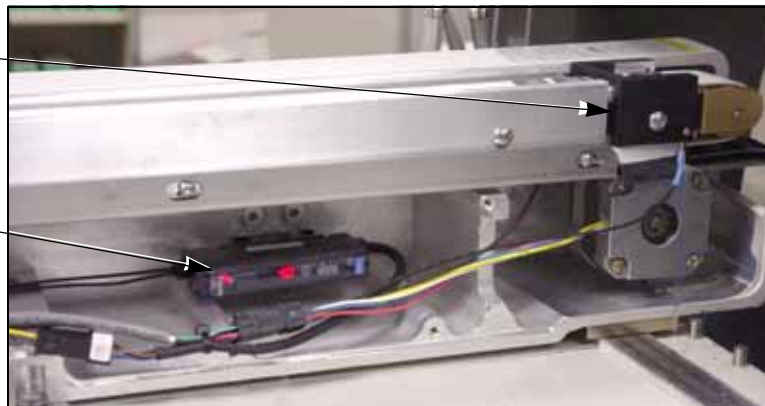

Figure S-22—Reteaching the End-of-Belt Sensor

8. Remove the device from the belt and then rotate the belt until the sensor controller displays its lowest value.
9. Push *Set* on the sensor controller again.



For details on setting the Sensor Controller see the label on the inside of the Conveyor Cover shown in Figure S-23.

NOTE: In general, the End-of-Belt Sensor Controller should display a number less than 21 when a device is present at the SMT pick point and greater than 90 when no device is present. If it is not possible to achieve numbers less than 21 and greater than 90 by adjusting the optic beam, the conveyor module must be replaced. (The Sensor Controller must always operate in “Turbo” mode.)

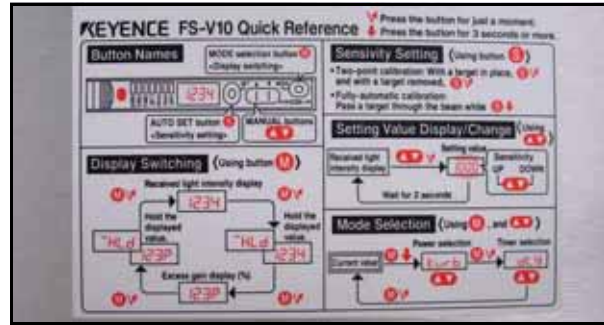

Figure S-23—End-of-Belt Sensor Controller Label on the Inside of the Conveyor Cover

S

S

Reject Bin

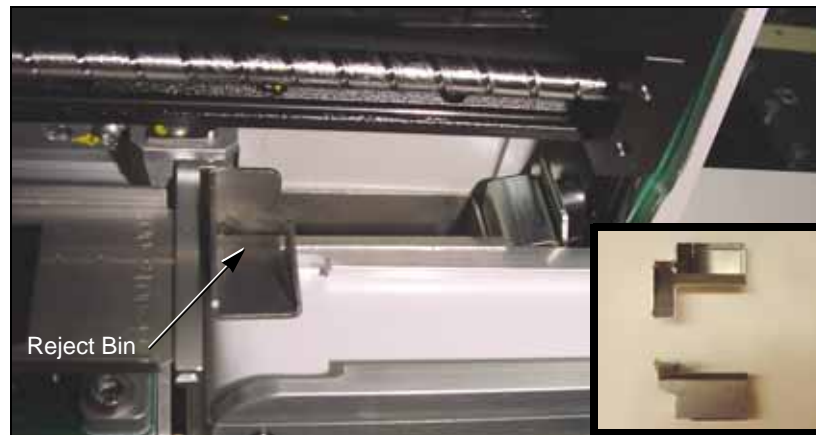

Figure S-24—The Reject Bin

The Reject Bin is not fastened in, and lifts out of the RoadRunner. Lift up and then out.

The Reject Bin Full Sensor senses when the bin is full and requires emptying. It is attached to the reject bin bracket.

S

Data I/O Parts Ordering Information

Instructions: 1. Copy this page. 2. Fill in your RoadRunner model and serial numbers (see the label on the chassis under the Robotics Cover). 3. Fill in the quantity for the item(s) desired. 4. Call Data I/O, or visit our Web site, for part prices (optional). 5. Mail or FAX it with your purchase order to Data I/O. See the last page of this manual for contact information.

ProLINE-RoadRunner Model No. _____ Serial No. _____

Model Name	Description	Qty	Price Ea.	Totals
REJECT BIN	Reject Bin		\$	\$
RR-REJECT BIN SENS	Reject Bin-Full Sensor		\$	\$
SLOT SENSOR CAB	Reject Bin-Present Sensor		\$	\$
ASSY,REJECT BIN,RR-uC	Reject Bin, Microcontroller		\$	\$
			\$	\$

Signature: _____ Date: _____ Company: _____

S

Removing the Reject Bin Full Sensor



For more information, see “Removing the Conveyor Module” on page S-23.

1. Turn the power off.
2. Disconnect the power cord and air supply.
3. Lift off the Robotics Cover.
4. Push the head away from the programmer.
5. Remove the Lower Cover.
6. Remove the Conveyor Module screws (the wires do not need to be unplugged) and lift it out of the way.
7. Lift out the Reject Bin.
8. Unplug the sensor wire connectors J1C and J1C2 from the Interconnect Panel. Cut wire ties as necessary.
9. Remove three socket head screws securing the Reject Bin Bracket to the chassis and lift it out.

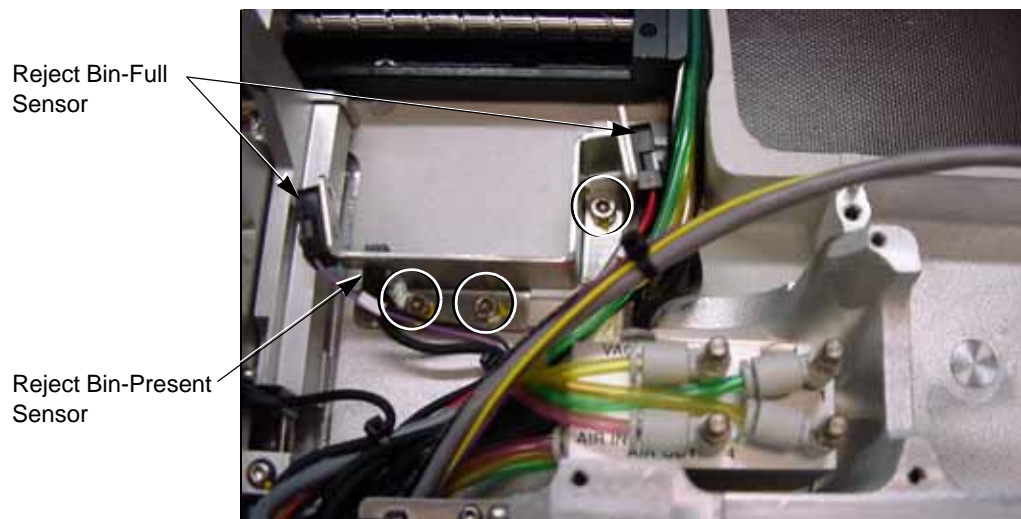

Figure S-25—Reject Bin Bracket Screw Locations.

10. Unscrew one screw through each sensor to remove the sensor.

NOTE: The Reject Bin-Full Sensor consists of two sensors. They should be replaced as a set.

To install the Reject Bin-Full Sensor, reverse the removal procedures:

- Reinstall the Sensors, and the Reject Bin Bracket
- Reinstall the Conveyor Module. Set the Conveyor height as described in “Reinstalling the Conveyor Module.”
- Reinstall the Lower Cover.

Control Panel Module

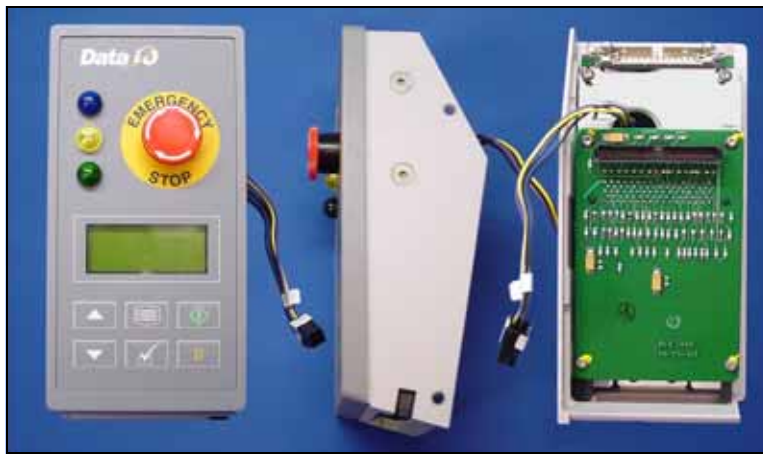

Figure S-26—Control Panel Module

The Control Panel Module consists of the PCMCIA Card Drive, the Stop button, the Indicator Lights, Control Panel buttons and LCD screen. If any of the components in the Control Panel Module are not functioning correctly, check the wiring connections and the condition of the PCMCIA card.

Test the PCMCIA Card Drive with a card that is known to function. If components are still not functioning after connections are tested, return the Control Panel Module to Data I/O for repair.

NOTE: Do not disassemble the Control Panel Module. If a component is not functioning, send the entire Control Panel Module back to Data I/O.

Data I/O Parts Ordering Information

Instructions: 1. Copy this page. 2. Fill in your RoadRunner model and serial numbers (see the label on the chassis under the Robotics Cover). 3. Fill in the quantity for the item(s) desired. 4. Call Data I/O, or visit our Web site, for part prices (optional). 5. Mail or FAX it with your purchase order to Data I/O. See the last page of this manual for contact information.

ProLINE-RoadRunner Model No. _____ Serial No. _____

Model Name	Description	Qty	Price Ea.	Totals
CONTROL PANEL M	Control Panel Module		\$	\$
			\$	\$
			\$	\$
			\$	\$

Signature: _____ Date: _____ Company: _____

S

S

Removing the Control Panel Module



See “Removing the Robotics Cover” on page S-5

1. Pause the RoadRunner.
2. Remove the PCMCIA card when the blue light is on.
3. Turn the power off.
4. Disconnect the RoadRunner power cord and air supply.
5. Remove the Robotics Cover.
6. Remove the PCMCIA Ribbon Cable Guard by unscrewing the two screws securing it.



Figure S-27—Ribbon Cable Guard Screw Locations

7. Unplug the PCMCIA Card Drive ribbon cable, the Control Panel Ribbon Cable, and the wires for the Emergency Stop button.

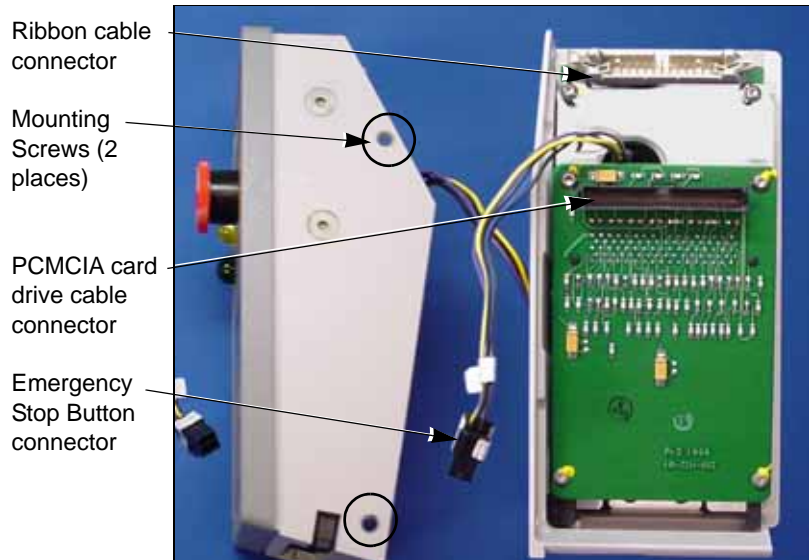

Figure S-28—Location of Connectors and Screws on the Control Panel.

8. Remove the screws securing the Control Panel Module to the RoadRunner chassis.

9. Remove the Control Panel Module.

Replacement is the in the reverse order of removal.

When reassembled, verify the proper operation of the following:

- Card Reader and indicator lamps
- Display
- Keypad
- Emergency Stop

S

S

Pick and Place Head

The head assembly contains four probes, each with Vacuum Tips and Vacuum Chamber Blocks. Some parts can be replaced and some probe functions can be adjusted.

Aligning the Head

Since device placement tolerance is small, the head may need aligning when a module is replaced or repaired. The head may also need aligning if any of the following error messages is displayed:

- Device pick failure at input, with probe *n*.
- Device pick failure on probe *n*.
- Device dropped from head *n*.

For head alignment procedures see “Setting the *Tape* Parameter” and “Setting the *Skt 1* Parameter” in Chapter 3 of the Owner's Manual.

Adjusting and Balancing Probe Speed

If the probe speed is too fast, devices in the carrier tape become unsettled as a probe strikes a device during the pick routine. If the probe speed is too slow, throughput will suffer and device placement problems may occur.

Adjust the probe speed with power and pressurized air on. Ensure that vacuum to all probes is disabled before starting this procedure. The easiest way to ensure this is to cycle the power.



See “Loading Device Tape” and “Aligning the Device Tape” in Chapter 3 of the Owner's Manual.

1. Load and align the device tape without peeling off the cover tape. (The Cover Tape Peel Bar and Spool will not be used.)

WARNING

Pinch point: Moving mechanical parts. Keep hands away from moving parts. The following procedures require the Robotics Cover to be removed while mechanical parts are in motion. Use caution.

2. Scroll to and select *Robot Diagnostics*.
3. Scroll to and select *Probe 1*.
4. Scroll to and select *Speed*. The probe will move to the device pick point and cycle continuously.
5. Read the speed that is now displayed in the screen. The speed should be 135 ± 5 .
If it needs adjustment skip to step 6.
If it does not need adjustment:

5a. Press *Menu*.

- 5b. Scroll to and select the next probe.
- 5c. Repeat steps 4 and on.
6. Remove the Conveyor Module Cover.
7. Loosen the locknut ring on the Probe Speed Flow Control for Probe 1 (or current probe) on the Interface Manifold.

The Interface Manifold is mounted on the chassis below, and to the right of, the Reject Bin.

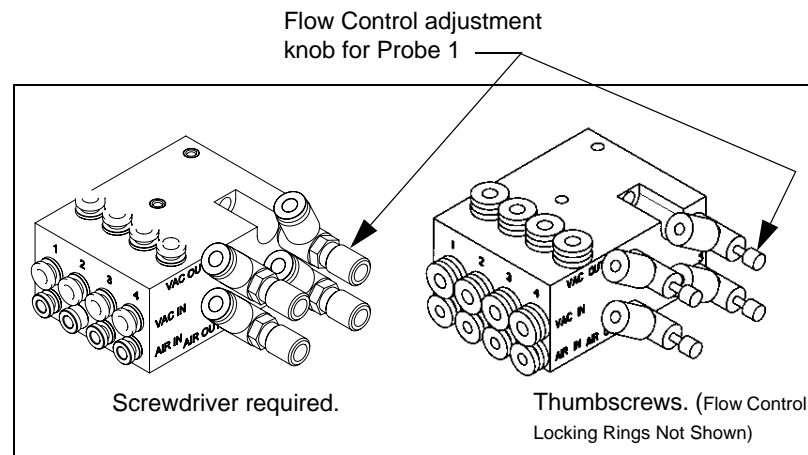

Figure S-29—Two Types of Interface Manifold used for Controlling Probe Speed

8. Adjust the Probe Speed flow control for Probe 1 (or current probe) while watching the speed displayed at the keypad screen.
9. When the speed is within the proper range, press *Menu*—probe motion will stop.
10. Tighten the locknut ring on the Flow Control.
11. Recheck the speed. If it is outside the proper range then readjust.
12. Scroll to and select the next Probe.
13. Repeat steps 4 and on for the next probe.

Resetting the *Pick* Delay and *Travel* Delay Times

The delay times do not change and do not usually require adjustment. The factory-set values are indicated in the following flow charts.

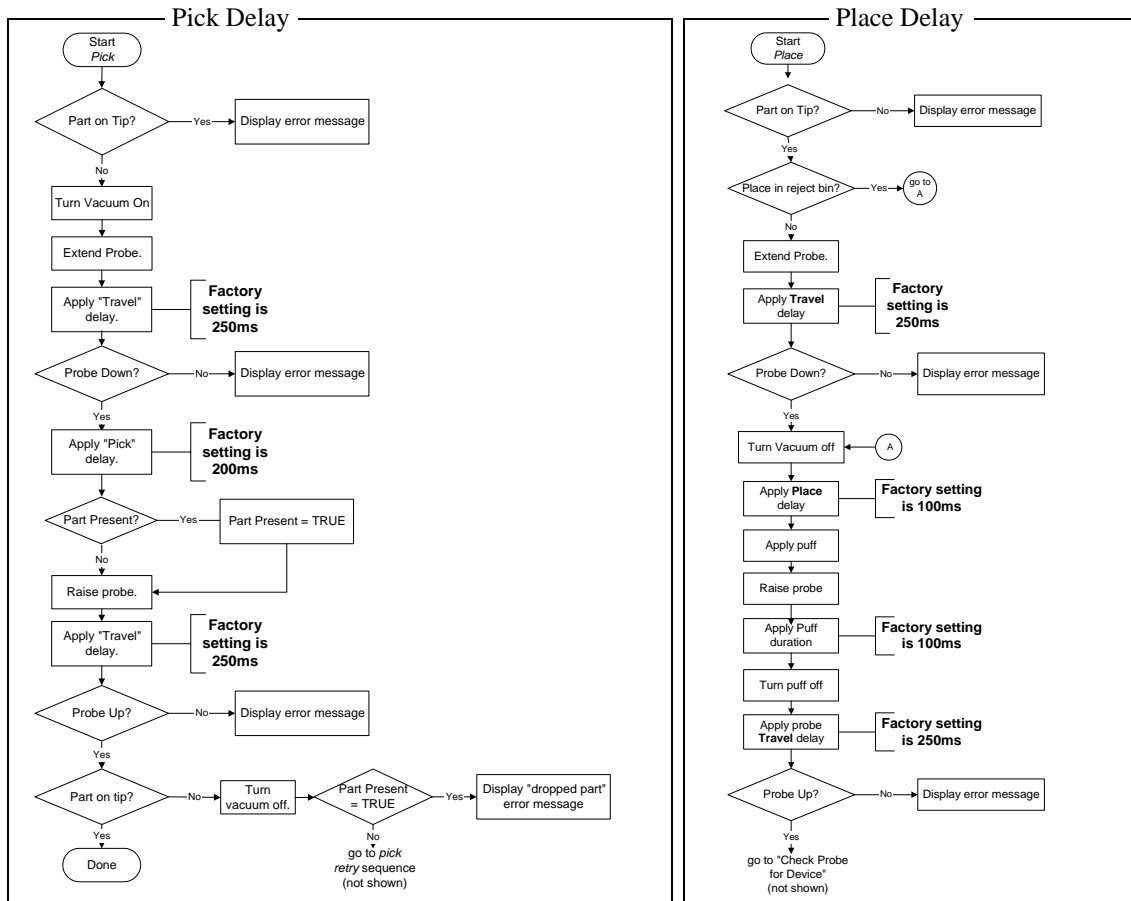

Figure S-30—Pick and Place Delay Flow Charts

These values only affect the internal verification delay time, as indicated in the flow charts.

To reset delay times:

1. From the top level menu on the display, select *Operation*.
2. Scroll to and select *Probes*.
3. Scroll to and select the setting you wish to adjust.
4. Use the *Arrow Up* and *Arrow Down* buttons to change the setting.
5. When finished, select *Menu*.

Adjusting Probe Vacuum Sensors



For more information . . .
See “Loading Device Tape”
in Chapter 3 of the Owner's
Manual.
See “Aligning the Device
Tape” in Chapter 3 of the
Owner's Manual.

1. Load *empty* device tape into RoadRunner.
2. Advance the tape until the hole in the center of a tape pocket is aligned within one scroll-button-increment of the scribe mark on the input tape module.
3. Push the Emergency Stop button.
4. Pushing the head with your hand, center the probe on the hole in the center of the device tape pocket.
5. Select *Menu* until you reach the top menu level and select *Robot Diagnostics*.
 - 5a. Scroll to and select *Probe 1*.
 - 5b. Scroll to and select *Vacuum*.
 - 5c. Press the *Up Arrow* to enable the probe.
6. Remove the Lower Cover.
7. Press Probe 1 down by hand until it contacts the tape pocket and hold it.
 - 7a. Turn the vacuum sensor adjust screw for Probe 1 (the first adjustment block) counter-clockwise until the red LED adjacent to the adjustment screw illuminates.

If the vacuum for Probe 1 is enabled, the two small LEDs on the solenoids for Probe 1 will be unlit.

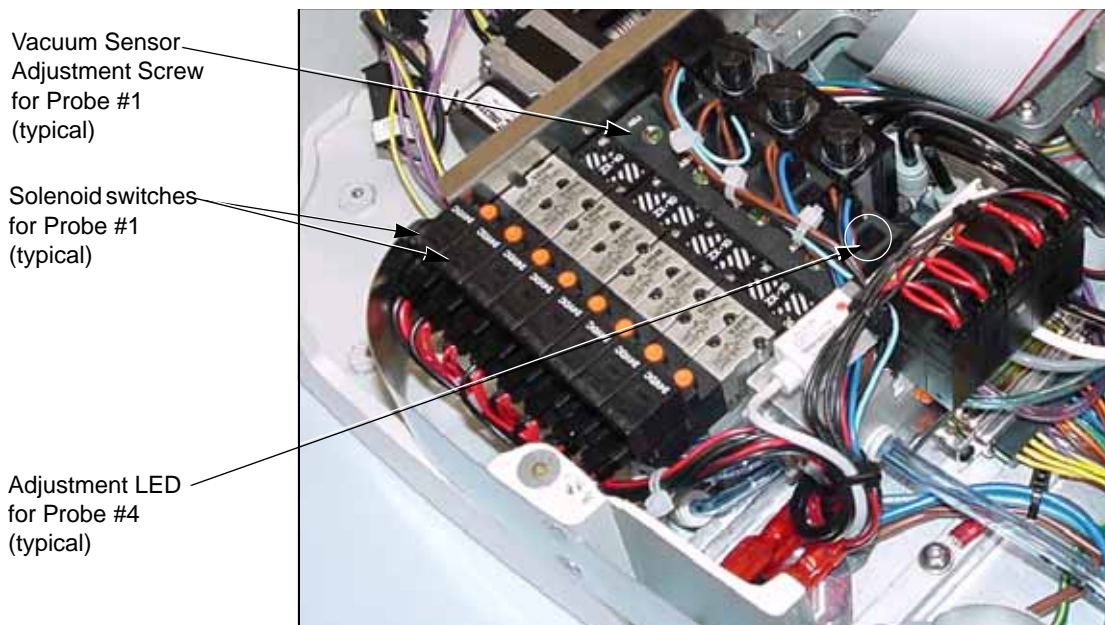

Figure S-31—Pneumatic Valve Block (#4 vacuum filter is removed)

- 7b. Turn the vacuum sensor adjust screw for Probe 1 clockwise until the red LED goes out. Continue turning the screw 1 revolution clockwise. Release the probe allowing it to resume the up position.
8. Select *Menu* until you reach the top menu level again and select *Robot Diagnostics*.
 - 8a. Scroll to and select *Probe 1*.
 - 8b. Scroll to and select *Vacuum*.
 - 8c. Press the *Down Arrow* to disable the probe.
9. Manually position probes 2, 3 and 4 over the hole in the tape pocket and repeat steps 5 through 7 for each.
10. Re-install the Lower Cover when finished.

Adjusting the Probe Position Sensor



Some models have a Probe Position Sensor on each side of the Head.



See “[Removing the Robotics Cover](#)” on page S-5.



See “[Removing the PNP Head](#)” on page S-38.

NOTE: Some models do not have Probe Position Sensors.

1. Remove the Robotics Cover.
2. Remove the PNP Head Cover.
3. Disconnect the air supply from the RoadRunner. (All probes will be in the raised position.)
4. At the top level menu on the display select *Robot Diagnostics*.
5. Select *Probe 1*.
6. Check that the *Position* field displays *Up*.
If not, with a 2mm hex driver loosen the two hex socket button head screws on each bracket—sender and receiver sensors—on either side of the head bracket. Adjust the sensor brackets until the *Position* field displays *Up*.
7. Manually push one probe down at a time and verify that the *Position* display toggles between *Up* and *Down*, corresponding with the probe’s physical position. If the *Position* field does not change as you move the probe, the sensors may be malfunctioning. Remove the PNP Head and send it to Data I/O Customer Service for repair or replacement.

Removing the PNP Head

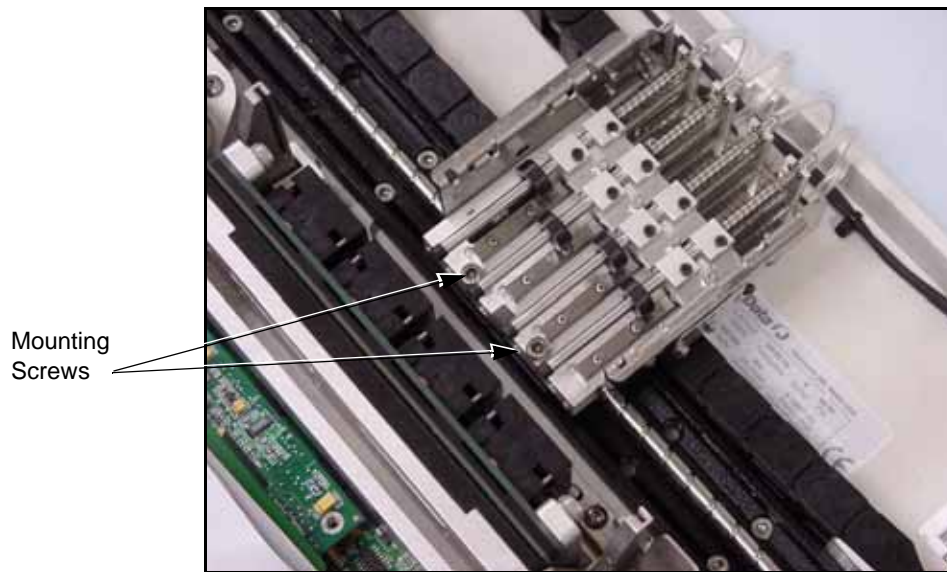

Figure S-32—Removing the PNP Head

If you receive error messages relating to the Pick and Place function, refer to the troubleshooting chart in chapter 9.

If you experience trouble with the Pick and Place Head that is not covered in this manual, remove the head and send it to Data I/O Customer Service for repair or replacement.

Removal procedures are on the following page.

Data I/O Parts Ordering Information

Instructions: 1. Copy this page. 2. Fill in your RoadRunner model and serial numbers (see the label on the chassis under the Robotics Cover). 3. Fill in the quantity for the item(s) desired. 4. Call Data I/O, or visit our Web site, for part prices (optional). 5. Mail or FAX it with your purchase order to Data I/O. See the last page of this manual for contact information.

ProLINE-RoadRunner Model No. _____ Serial No. _____

Model Name	Description	Qty	Price Ea.	Totals
PNP HEAD	Pick and Place Head		\$	\$
			\$	\$
			\$	\$
			\$	\$

Signature: _____ Date: _____ Company: _____

S

S

To remove the Pick and Place Head:

1. Turn the power off.
2. Disconnect the RoadRunner power cord and air supply.
3. Remove the Robotics Cover.
4. Remove the PNP Head Cover.
5. Disconnect the tube from the top of each probe.
6. Remove two socket head cap screws attaching the head to the ball screw carriage.
7. Lightly pull the head a couple of centimeters away from the carriage.
8. Remove four pneumatic tubes with fittings from the back of the head with a straight screwdriver. Note that each has a washer.



For screw locations see
Figure S-32 on page S-38.

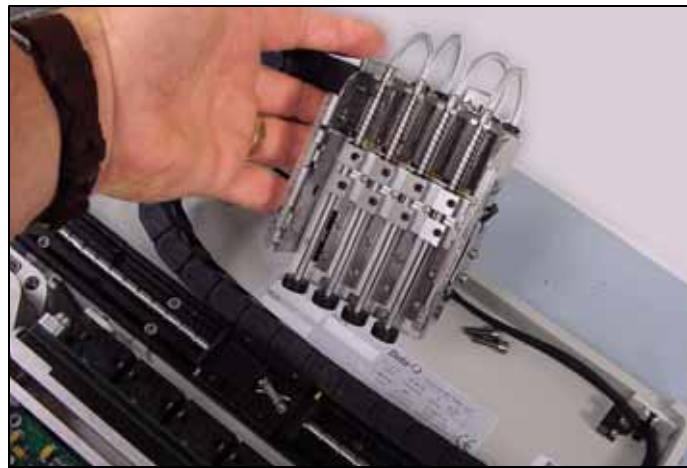

Figure S-33—The PNP Head Partially Removed



Some models have Probe
Position Sensors.



NOTE: Perform the next two steps only if your model has sensors on each side of the head.

9. Disconnect one electrical connector by pressing the flexible clip. You may have to cut one cable tie.
10. Loosen two screws each securing two Probe Position Sensor Brackets to the sides of the Head if necessary for access to the Head Bracket screws.
11. Remove two Head Bracket screws from each side of the head.

To reinstall a PNP Head, reverse the steps for removal *and* perform the following:

1. Install the four fittings onto the new head—the tubes are still attached. Ensure that each has a gasket.
2. Install the head Bracket onto the head.

3. Plug in the electric connector and tie wrap to the tie wrap block.
4. Attach the tubes to the probes.
5. Install the head to the Linear stage with the two socket screws. Use Loctite.
6. Adjust both Sensor Brackets (some models) and tighten the screws.
7. Perform the “Linear Stage Reinstallation Verification” procedure.
8. Perform the “Adjusting the Probe Position Sensor” adjustment.



For more information, see the “[Linear Stage Installation Verification](#)” on page S-50.

For Adjusting the Probe Position Sensor, see [page S-37](#).

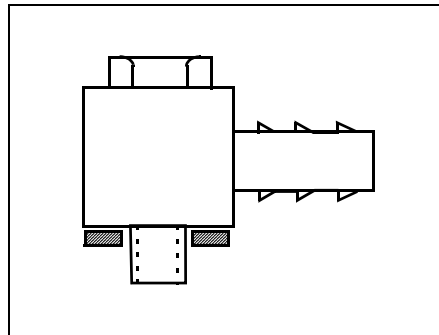

Figure S-34—Tube Fitting with Gasket

Blank page.

S

S

Programmer Module

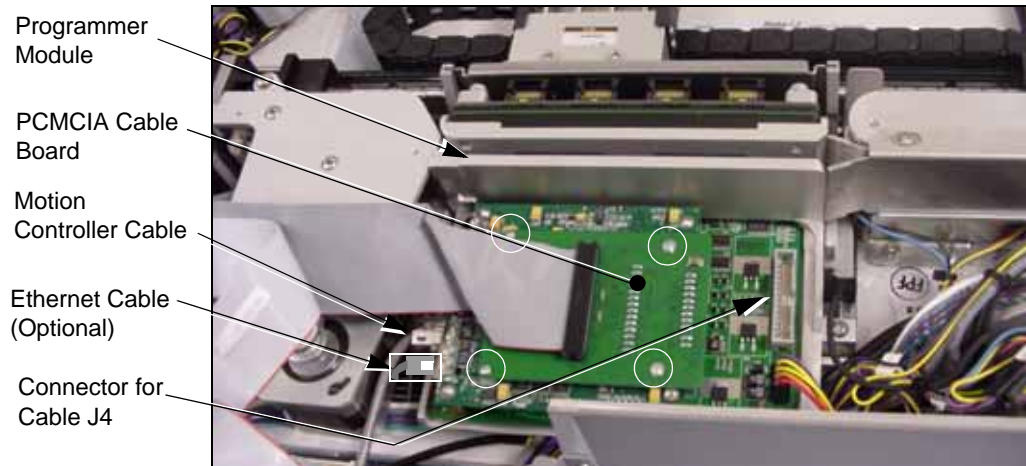

Figure S-35—Programmer Module. Cable J4 has been Unplugged. The PCMCIA Cable PCB Screws are Circled

The Programmer Module consists of the WaveForm Board, the Main Controller Board, the BackPlane Board, and the pneumatic actuator that opens and closes the programmer sockets.

If Programmer Module sockets become worn, the Socket Adapter needs attention. The Socket Adapter needs cleaning when yield drops, and needs replacing when cleaning fails to boost yield.

If replacing the Socket Adapter does not solve problems in the Programmer Module, see “Diagnosing with the Adapter Board” in Chapter 5 of the Owner's Manual, or contact Data I/O for Programmer Module replacement or repair. Programmer Module removal directions start on [page S-43](#).



Refer to “Changing the Socket Adapter” in Chapter 3 of the Owner's Manual.

Data I/O Parts Ordering Information

Instructions: 1. Copy this page. 2. Fill in your RoadRunner model and serial numbers (see the label on the chassis under the Robotics Cover). 3. Fill in the quantity for the item(s) desired. 4. Call Data I/O, or visit our Web site, for part prices (optional). 5. Mail or FAX it with your purchase order to Data I/O. See the last page of this manual for contact information.

ProLINE-RoadRunner Model No. _____ Serial No. _____

Model Name	Description	Qty	Price Ea.	Totals
RR-PROGRAMMER MOD	Programmer Module		\$	\$
PROGRAMMER ALIGNMENT TOOL	Programmer Module Alignment Tool		\$	\$
ASSY,PROGRAMMER W/GUIDE,RR-uC	Programmer Module, Microcontroller		\$	\$
			\$	\$

Signature: _____ Date: _____ Company: _____

Removing the Programmer Module

NOTE: Only technicians who have taken the Advance ProLINE-RoadRunner training course should attempt to remove the Programmer Module.

A special alignment tool is required from Data I/O to reinstall the Programmer Module.



See “Changing the Socket Adapter” on page 3-5.

See “Removing the Conveyor Module” on page S-23

1. Switch the power off.
2. Disconnect the RoadRunner power cord and air supply.
3. Lift off the Robotics Cover.
4. Push the head away from the programmer.
5. Remove the Lower Cover.
6. Remove the Actuator Plate by sliding it out of the bracket.
7. Optional: Remove the Socket Adapter.
8. Remove the Conveyor Module Cover.
9. Lift out the Reject Bin.
10. Remove screws from the Conveyor Module and set it aside—wires are still attached.
11. Remove the Reject Bin Bracket. Sensors do not need to be removed. Wires do not need to be unplugged. Move it out of the way.

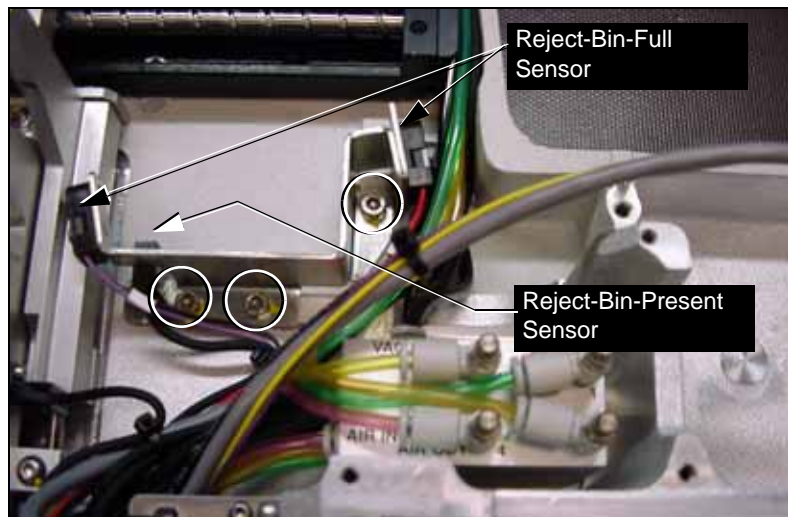

Figure S-36—Locations of Reject Bin Bracket Screws.



See Cable J4 in Figure S-35, as well as screws for the PCMCIA Cable PCB.

See Cable J3 in Figure S-37.

CAUTION: Ribbon Cables might get damaged if pulled or pinched. Cable damage is often not visible. Pull cables by the connector only.

12. Unplug the Ribbon Cable J4 from the Programmer Module.
13. Unplug the Cable J3 from the Programmer Module.
14. Remove the PCMCIA Cable PCB by removing four socket-head cap screws and lifting up on the PCB. Set it aside—the cable is still attached.
15. Unplug the Motion Controller Cable (709-0560) from the left side of the Programmer Module.
16. If equipped, unplug the Ethernet Cable (701-3215) from the left side of the Programmer Module, adjacent to the Motion Controller Cable.

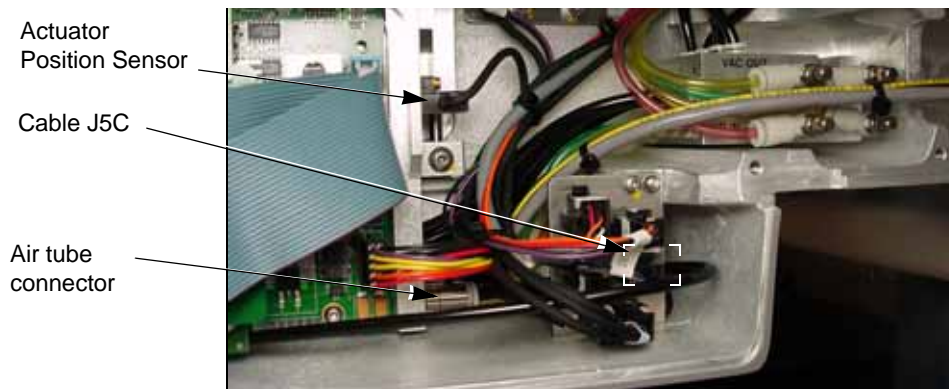

Figure S-37—Cable Interconnect Panel



See Cable J5C in Figure S-37.

17. Disconnect the air tube from the Programmer Module. It is a one-touch fitting.
18. Disconnect the Programmer Module's Actuator Position Sensor Cable, J5C, from the Cable Interconnect Panel. Cut the cable ties.



Figure S-38—Cable J3 and Header J4 Locations

19. Remove four button head socket screws attaching the Programmer Module to the chassis.

NOTE: If there are shims under the Programmer Module it is an old model. If you are installing a new Module, discard the shims.



Figure S-39—Location of Programmer Screws

20. Lift the Programmer Module out from the chassis.

Reinstalling the Programmer Module

To reinstall a Programmer Module perform the following steps:

1. Reinstall a Programmer Module ensuring that no wires or hoses are pinched, and tighten the four screws.
2. Reinstall the air tube.
3. Reinstall all cable connectors.
4. Plug in the PCMCIA Cable PCB and install the four screws.

Align the Programmer Module as described below before completing reinstallation.

Aligning Programmer Module

Align the Programmer Module as follows:



Figure S-40—The Programmer Module Alignment Tool Installed on the Programmer

CAUTION: Chassis might get damaged. Loosen the Programmer Module mounting screws (two upper screws) before each attempt to adjust the Programmer Alignment Screws.

1. Install the Programmer Alignment Tool (model name PROGRAMMER ALIGNMENT TOOL) onto the Programmer Module in place of a socket adapter.
2. Loosen the upper two Programmer Module mounting screws two revolutions.
3. Remove the rubber tip from Probe 1 and extend Probe 1 into the alignment fixture hole for socket #1. If the probe **passes** through the hole easily, then the left side of the programmer is properly aligned—skip to step 4.
 - 3a. If Probe 1 **does not pass** through easily, adjust the left Position Adjustment set screw so that the probe does pass through easily. Turn the screw clockwise to move the module away from the chassis.



Figure S-41—Programmer Module Alignment Screws (the Left Screw is not shown)

4. Without the rubber tip on, extend Probe 4 into the alignment fixture hole for socket #4. If the probe **passes** through the hole easily, then the right side of the programmer is properly aligned—skip to step 5.
 - 4a. If probe 4 **does not pass** through easily, adjust the right Position Adjustment set screw accordingly.
5. Tighten the upper two Programmer Module screws and **retest**. If the module requires further adjustment, be sure to loosen the upper two mounting screws first.
6. Remove the Alignment Tool.

Complete the Programmer Module installation by installing the Reject Bin Bracket, the Conveyor Module, the Reject Bin, and the Lower Cover.

S

S

Linear Stage Module

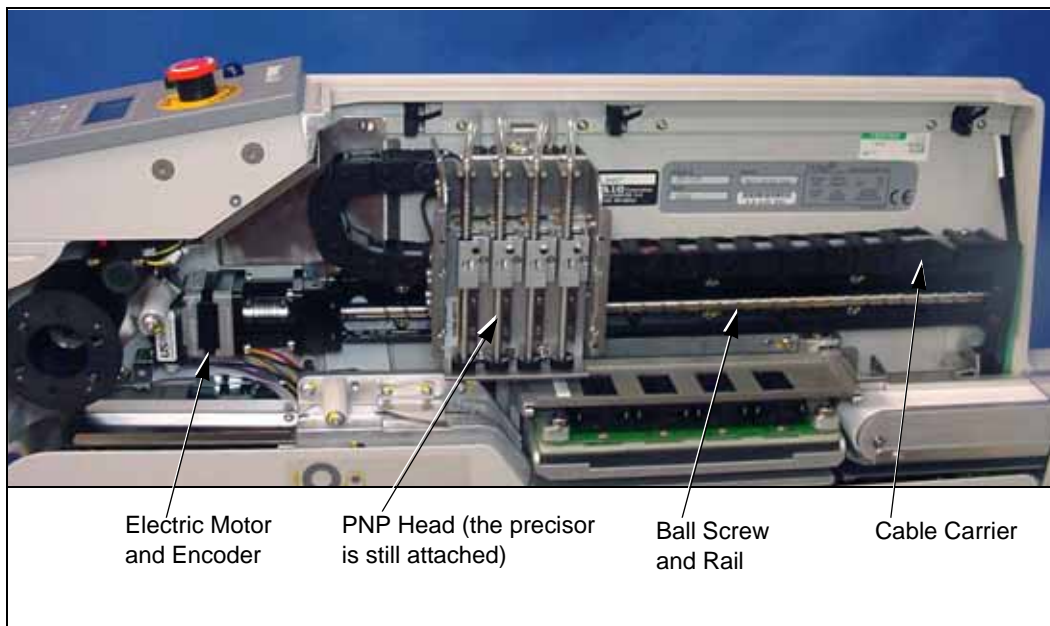

Figure S-42—The Linear Stage Module

S



To remove the PNP Head only, see “Removing the PNP Head” on page S-38.

The Linear Stage, part of the Robotic System, consists of the ball screw and a stepper motor. The Linear Stage, which includes the cable carrier, is removed as a module with the PNP Head.

Data I/O Parts Ordering Information

Instructions: 1. Copy this page. 2. Fill in your RoadRunner model and serial numbers (see the label on the chassis under the Robotics Cover). 3. Fill in the quantity for the item(s) desired. 4. Call Data I/O, or visit our Web site, for part prices (optional). 5. Mail or FAX it with your purchase order to Data I/O. See the last page of this manual for contact information.

ProLINE-RoadRunner Model No. _____ Serial No. _____

Model Name	Description	Qty	Price Ea.	Totals
RR-LINEAR MODULE	Linear Stage Module		\$	\$
			\$	\$
			\$	\$

Signature: _____ Date: _____ Company: _____

S

Removing the Linear Stage Module



For more information, see
“Removing the Lower
Cover” on page S-5.



For more information, see
“Removing the Conveyor
Module” on page S-23.

1. Switch the power off.
2. Disconnect the RoadRunner power cord and air supply.
3. Lift off the Robotics Cover.
4. Pull off the PNP Head Cover. It is magnetically attached to the head.
5. Remove the Lower Cover.
6. Remove the Conveyor Module Cover.
7. Remove the Conveyor Module screws (the wires do not need to be unplugged) and lift it out of the way.
8. Lift out the Reject Bin.
9. (Label if necessary and) disconnect four *black* Linear Stage air hoses from the Interface Manifold’s upper surface. The Interface Manifold is located below the Reject Bin Bracket.
10. (Label if necessary and) disconnect four *colored* air hoses from the Interface Manifold.
11. Unplug electrical connector J8B from the extension cable connector. It goes to the linear stage motor. The cable is tucked beneath the Tape-In Module and pulls out far enough for connector access. See figure below.

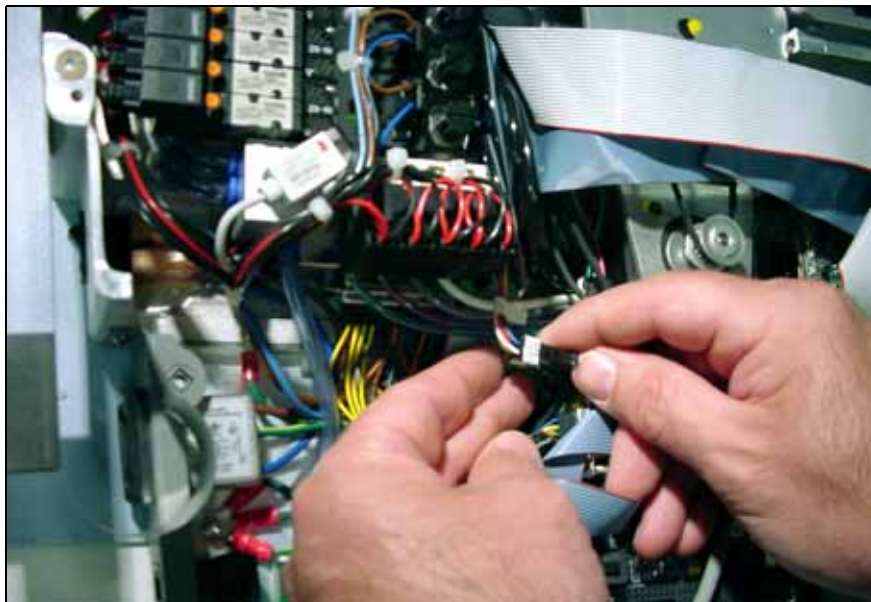

Figure S-43—Wires from the Linear Stage Motor terminate at intermediate connector J8B below the Tape-In Module.

12. (On early models only) Unplug electrical connector J2C from the Interconnect Panel located below the reject bin bracket. It goes to the Heads-Up Sensor on the PNP head.

13. Remove eight screws securing the linear stage to the chassis. (Slide the head out of the way.) See the figure below.



Figure S-44—Linear Stage Screw Locations. (Two are hidden by the head.)

14. Lift the Linear Stage Module slightly away from the chassis and unplug the ribbon cable at the encoder.



Figure S-45—Disconnecting the Ribbon Cable from the Encoder.

Linear Stage Installation Verification

To replace the Linear Stage Module, reverse the steps for removal and perform the following:

1. With the power off, cycle the PNP Head along the entire length of the Linear Stage. Check that the Head Flag clears all three position sensors.
2. Verify electrical and pneumatic connections as follows:
 - 2a. Connect the air hose and turn the power on.
 - 2b. Verify that the head homes.
 - 2c. Verify that the *Position* field at the keypad display toggles when each probe is lowered by hand. *Robot Diagnostics » Probe X » Position*.
 - 2d. Extend and retract each probe to verify correct plumbing. *Robot Diagnostics » Probe X » Position » Arrow Up/Down*.



For probe vacuum settings see [“Adjusting Probe Vacuum Sensors”](#) on page S-36.

For probe speed information see [“Adjusting and Balancing Probe Speed”](#) on page S-33.

For Programmer alignment see [“Aligning Programmer Module”](#) on page S-45.

For reteaching the robot see [“Setting Operational Parameters”](#) on page 3-19.

- 2e. Enable vacuum to each probe to verify correct plumbing. *Robot Diagnostics » Probe X » Vac Sense » Arrow Up/Down.*
3. Adjust the Probe Vacuum Sensors.
4. Verify correct Probe Speed.
5. Perform the “Aligning the Programmer Module” procedure.
6. Reteach the robot the four operation parameters: Tape, Socket1, Reject and Belt.

Basic Spares Kit, Memory RoadRunner

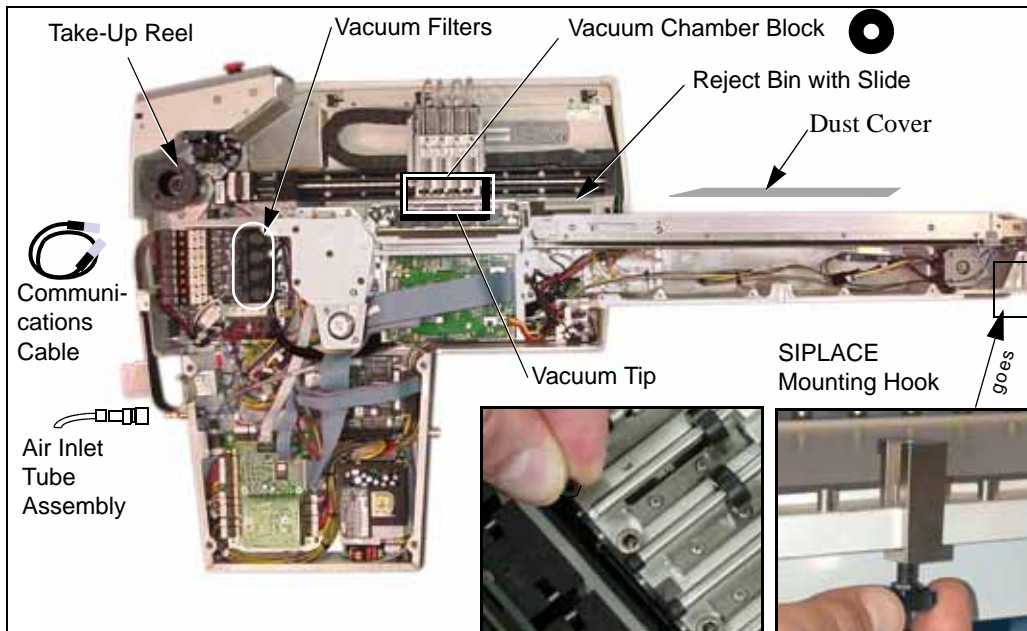

Figure S-46—Locating parts in the Basic Spares Kit; Memory RoadRunner

Two spare parts kits are available for the Memory RoadRunner. Parts in the Basic Spares Kit are listed below. For the larger “Self-Service Spares Kit,” see [page S-54](#).

Data I/O Parts Ordering Information

Instructions: 1. Copy this page. 2. Fill in your RoadRunner model and serial numbers (see the label on the chassis under the Robotics Cover). 3. Fill in the quantity for the item(s) desired. 4. Call Data I/O, or visit our Web site, for part prices (optional). 5. Mail or FAX it with your purchase order to Data I/O. See the last page of this manual for contact information.

ProLINE-RoadRunner Model No. _____ Serial No. _____

Model Name	Description	Qty	Price Ea.	Totals
RR-VAC TIP	Vacuum Tip		\$	\$
RR-VAC FILTER	Probe Vacuum Filter		\$	\$
RR-ASSY AIR TUBE	Air Inlet Tube Assembly		\$	\$
RR-REJECT BIN	Reject Bin		\$	\$
RR-COVER TAPE HUB	Cover Tape Take-Up Reel, Slotted		\$	\$
RR-SLEEVE TAKE UP WHEEL 6 HL	Cover Tape Take-Up Reel, 6 Holes		\$	\$
RR-CHAMBER FLOATING BLOCK	Vacuum Chamber Block		\$	\$
RR-HOOK, SIEMENS	SIPLACE Mounting Hook (no Knob)		\$	\$
HOOK, SIEMENS(THUMB SCREW)	Knob, Thumb Screw (for Mntng Hook)		\$	\$
RR-COVER DUST-S	Conveyor Dust Cover		\$	\$
RR-CABLE COMM-S	Siemens Communications Cable		\$	\$
RR-BASIC SPARES KIT-S	Basic Spares Kit (all the above)		\$	\$

Signature: _____ Date: _____ Company: _____

Replacing the Probe Tips

The rubber tip pulls straight off. Hold a new tip with the square hole oriented to the square end of the probe and work it on to the probe.

Replacing the Air Inlet Tube Assembly

To remove the Air Inlet Tube Assembly at the RoadRunner air connector:

1. Stop or pause the job if one is running.
2. If there are any devices currently on the probes, remove them; they will fall off when air is removed.
3. Pull the collar on the quick release fitting back as you pull the tube assembly off the connector. (The quick release fitting has a safety shut off feature—the compressed air need not be turned off.)

To connect an Air Inlet Tube Assembly, push it onto the RoadRunner connector.

Replacing the Mounting Hook

The **SIPLACE Mounting Hook** is a separate piece of the RoadRunner. To replace the SIPLACE Hook, the RoadRunner must be dismounted from the feeder cart, and the feeder cart removed from the SMT machine. See *Mounting the RoadRunner* in Chapter 2 of the Owner's Manual.

CAUTION: *There are two different Mounting Hooks for RoadRunner for Siemens. The label on your RoadRunner conveyor will show a silver hook or a black hook—use the correct color as shown on the label.*

Self-Service Spares Kit, Memory RoadRunner

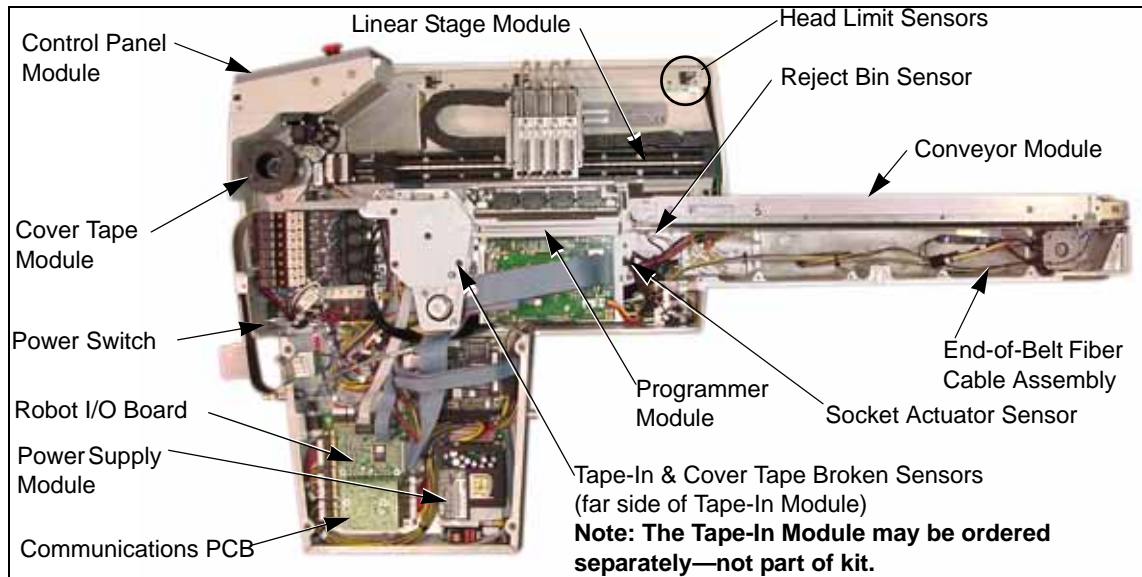

Figure S-47—Parts in the Self-Service Spares Kit; Memory RoadRunner

S

Data I/O Parts Ordering Information

Instructions: 1. Copy this page. 2. Fill in your RoadRunner model and serial numbers (see the label on the chassis under the Robotics Cover). 3. Fill in the quantity for the item(s) desired. 4. Call Data I/O, or visit our Web site, for part prices (optional). 5. Mail or FAX it with your purchase order to Data I/O. See the last page of this manual for contact information.

ProLINE-RoadRunner Model No. _____ Serial No. _____

Model Name	Description	Qty	Price Ea.	Totals
RR-PWR SWITCH	Power Switch, Rocker		\$	\$
RR-PWR SUPPLY	Power Supply Module		\$	\$
RR-LIMIT SENSOR CA	Head Limit Sensor (Cable Assy/Sensor)		\$	\$
RR-SLOT SENSOR CA	Slot Sensor Cable Assembly (Tape sensors)		\$	\$
RR-REJECT BIN SENS	Reject Bin Sensor		\$	\$
RR-FIBER OPTIC CA	End-of-Belt Fiber Cable Assembly		\$	\$
RR-LINEAR MODULE	Linear Stage Module		\$	\$
RR-ASSY CONV, SIEMENS	Conveyor Module		\$	\$
RR-PROGRAMMER MOD	Programmer Module		\$	\$
RR-CTRL PNL MODULE	Control Panel Module		\$	\$
RR-COVER TAPE MOD	Cover Tape Module		\$	\$
RR-ROBOT I/O COMM	Robot I/O Board Module		\$	\$
RR-PCMCIA CABLE	PCMCIA PCB Cable Assy		\$	\$
RR-PNEUMATIC MODULE	Pneumatic Module		\$	\$
RR-OPTIC SENSOR	Optic Fiber		\$	\$
RR-SMT COMM PORT	SMT Communications PCB		\$	\$
RR-DIAGNOSTICS BOARD	Diagnostics Adapter Board (DAB)		\$	\$
PROGRAMMER ALIGNMENT TOOL	Programmer Alignment Tool		\$	\$

Signature: _____ Date: _____ Company: _____

S

The Self-Service Spares Kit (RR-SELFSV SPARES KIT-SC) is listed contains the parts listed on the previous page. It is available to those who have attended an Advanced RoadRunner Service course.

Customer Training

For information about advanced training, contact the Data I/O Customer Service Center. The training course may be ordered when purchasing a RoadRunner or at a later time.

NOTE: This manual does not list replacement instructions for all the parts in the Self-Service Spares Kit. For additional information, contact Data I/O or your nearest authorized representative. To find your nearest representative, see the instructions on the last page of this manual.

Basic Spares Kit, Microcontroller RoadRunner

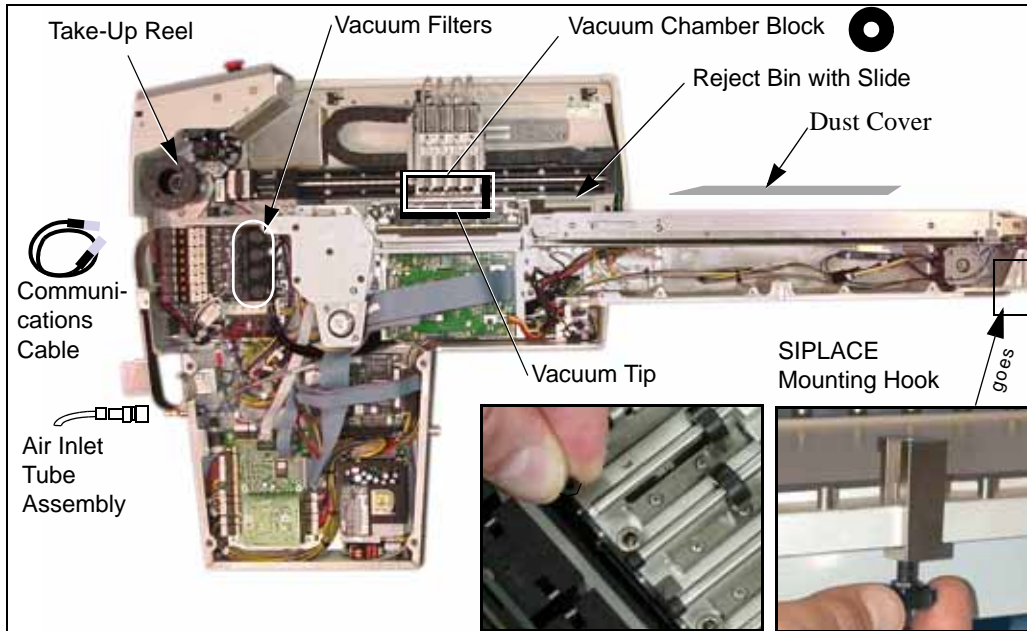

Figure S-48—parts in the Basic Spares Kit; Microcontroller RoadRunner

Two spare parts kits are available for the Microcontroller RoadRunner. Parts in the Basic Spares Kit are listed below. For the larger “Self-Service Spares Kit,” see [page S-58](#).

Data I/O Parts Ordering Information

Instructions: 1. Copy this page. 2. Fill in your RoadRunner model and serial numbers (see the label on the chassis under the Robotics Cover). 3. Fill in the quantity for the item(s) desired. 4. Call Data I/O, or visit our Web site, for part prices (optional). 5. Mail or FAX it with your purchase order to Data I/O. See the last page of this manual for contact information.

ProLINE-RoadRunner Model No. _____ Serial No. _____

Model Name	Description	Qty	Price Ea.	Totals
RR-VAC TIP	Vacuum Tip		\$	\$
RR-VAC FILTER	Probe Vacuum Filter		\$	\$
RR-ASSY AIR TUBE	Air Inlet Tube Assembly		\$	\$
ASSY,REJECT BIN,RR-uC	Reject Bin, Microcontroller		\$	\$
RR-COVER TAPE HUB	Cover Tape Take-Up Reel, Slotted		\$	\$
RR-SLEEVE TAKE UP WHEEL 6 HL	Cover Tape Take-Up Reel, 6 Holes		\$	\$
RR-CHAMBER FLOATING BLOCK	Vacuum Chamber Block		\$	\$
RR-HOOK, SIEMENS	SIPLACE Mounting Hook (no Knob)		\$	\$
HOOK, SIEMENS(THUMB SCREW)	Knob, Thumb Screw (for Mntng Hook)		\$	\$
RR-COVER DUST-S	Conveyor Dust Cover		\$	\$
RR-CABLE COMM-S	Siemens Communications Cable		\$	\$
RR-BASIC SPARES KIT-S	Basic Spares Kit for uC (all the above)		\$	\$

Signature: _____ Date: _____ Company: _____

Replacing the Probe Tips

The rubber tip pulls straight off. Hold a new tip with the square hole oriented to the square end of the probe and work it on to the probe.

Replacing the Air Inlet Tube Assembly

To remove the Air Inlet Tube Assembly at the RoadRunner air connector:

1. Stop or pause the job if one is running.
2. If there are any devices currently on the probes, remove them; they will fall off when air is removed.
3. Pull the collar on the quick release fitting back as you pull the tube assembly off the connector. (The quick release fitting has a safety shut off feature—the compressed air need not be turned off.)

To connect an Air Inlet Tube Assembly, push it onto the RoadRunner connector.

Replacing the Mounting Hook

The **SIPLACE Mounting Hook** is a separate piece of the RoadRunner. To replace the SIPLACE Hook, the RoadRunner must be dismantled from the feeder cart, and the feeder cart removed from the SMT machine. See *Mounting the RoadRunner* in Chapter 2 of the Owner's Manual.

Self-Service Spares Kit, Microcontroller RoadRunner

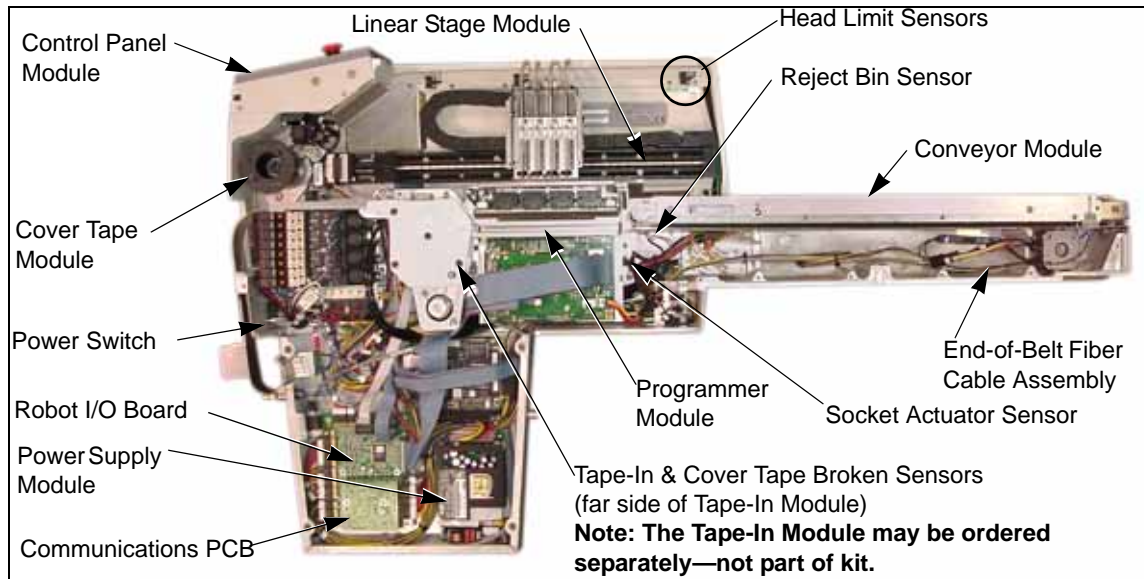

Figure S-49—Self-Service Spares Kit; Microcontroller RoadRunner

Data I/O Parts Ordering Information

Instructions: 1. Copy this page. 2. Fill in your RoadRunner model and serial numbers (see the label on the chassis under the Robotics Cover). 3. Fill in the quantity for the item(s) desired. 4. Call Data I/O, or visit our Web site, for part prices (optional). 5. Mail or FAX it with your purchase order to Data I/O. See the last page of this manual for contact information.

ProLINE-RoadRunner Model No. _____ Serial No. _____

Model Name	Description	Qty	Price Ea.	Totals
RR-PWR SWITCH	Power Switch, Rocker		\$	\$
RR-PWR SUPPLY	Power Supply Module		\$	\$
RR-LIMIT SENSOR CA	Head Limit Sensor (Cable Assy/Sensor)		\$	\$
RR-SLOT SENSOR CA	Slot Sensor Cable Assembly (Tape sensors)		\$	\$
RR-REJECT BIN SENS	Reject Bin Sensor		\$	\$
RR-FIBER OPTIC CA	End-of-Belt Fiber Cable Assembly		\$	\$
RR-LINEAR MODULE	Linear Stage Module		\$	\$
ASSY,CONVEYOR 16MM,SIE-MENS,RR- μ C	Conveyor Module, Microcontroller		\$	\$
ASSY,PROGRAMMER W/GUIDE,RR- μ C	Programmer Module, Microcontroller		\$	\$
RR-CTRL PNL MODULE	Control Panel Module		\$	\$
RR-COVER TAPE MOD	Cover Tape Module		\$	\$
RR-ROBOT I/O COMM	Robot I/O Board Module		\$	\$
RR-PCMCIA CABLE	PCMCIA PCB Cable Assy		\$	\$
RR-PNEUMATIC MODULE	Pneumatic Module		\$	\$
RR-OPTIC SENSOR	Optic Fiber		\$	\$
RR-SMT COMM PORT	SMT Communications PCB		\$	\$
RR-DIAGNOSTICS BOARD	Diagnostics Adapter Board (DAB)		\$	\$
PROGRAMMER ALIGNMENT TOOL	Programmer Alignment Tool		\$	\$

Signature: _____ Date: _____ Company: _____

The Self-Service Spares Kit for the Microcontroller RoadRunner (RR-MICRO-SELFSV SPARES KIT-S) is listed contains the parts listed on the previous page. It is available to those who have attended an Advanced RoadRunner Service course.

Customer Training

For information about advanced training, contact the Data I/O Customer Service Center. The training course may be ordered when purchasing a RoadRunner or at a later time.

NOTE: This manual does not list replacement instructions for all the parts in the Self-Service Spares Kit. For additional information, contact Data I/O or your nearest authorized representative. To find your nearest representative, see the instructions on the last page of this manual.

Socket Adapter, Actuator, and Precisor

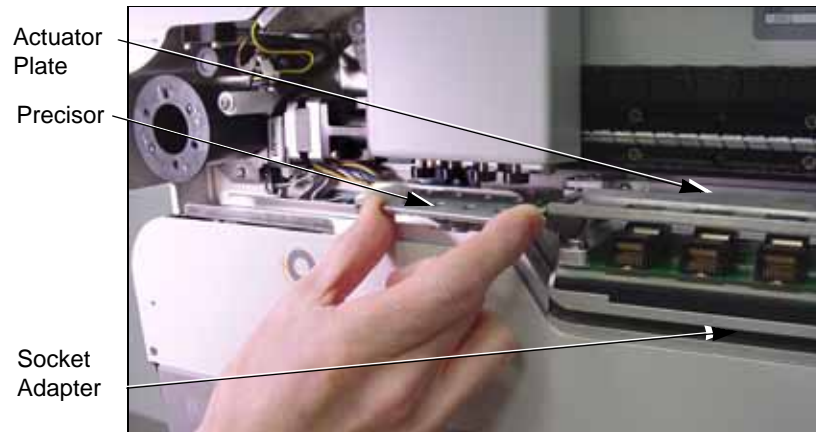

Figure S-50—Precisor, Actuator, and Socket Adapter Locations

A precisor is a plate that assists in aligning devices on the probes before they are placed into the programming sockets.

The Actuator Plate opens the sockets on the Socket Adapter (assisted by air cylinders).

The Socket Adapter is the interface between the specific device and the programmer. Socket manufacturers' specifications are used for expected socket life.

Since these three parts—Precisor Plate, Actuator Plate and Socket Adapter—are determined by the device package, they may need to be replaced for each new device type you wish to program. Call Data I/O Customer Service, or contact your nearest authorized Data I/O representative for parts or device programming kits. Contact information is on the last page of this manual.

See the ProLINE-RoadRunner Owner's Manual for the following:

- To remove the **Precisor** see *Changing the Precisor* in Chapter 3
- To remove the **Actuator Plate** see *Changing the Actuator Plate* in Chapter 3.
- To remove the **Socket Adapter** see *Changing the Socket Adapter* in Chapter 3.

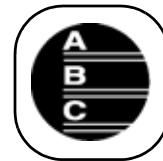

Index

A

- Adjustable Tape-In Module
 - aligning S-10
 - removing S-9
- Air Filters
 - description S-14
 - ordering S-14
 - replacing S-15
- Air Paths, keeping clean S-14

B

- Basic Spares Kit
 - Memory S-52
 - Microcontroller S-56
 - ordering S-52, S-56
- Black Hook S-53
- Broken tape sensor S-12

C

- Components, listed S-2
- Contact Information. See inside back cover.
- Control Panel
 - removing S-31
- Control Panel Module
 - ordering S-30
- Conveyor Belt Cover, removing S-6
- Conveyor Drive Belt, adjust S-23

- Conveyor Dust Cover, removing S-5
- Conveyor Module S-22, S-26, S-54, S-58
 - drop height S-23
 - reinstalling S-23
 - removing S-23
- Cover Tape Module
 - ordering S-20
 - removing S-21
- Cover Tape-broken sensor S-12
- Covers, ordering S-4
- Customer Training S-55, S-59

D

- Delay Times, resetting S-35

E

- Electrostatic Discharge iii
- End-of-Belt Sensor
 - adjusting S-25
 - reteaching S-26
 - Testing S-25
- ESD. See Electrostatic Discharge

F

- Flow Control Manifold S-34
- Front Cover, removing S-5

G

Grounding iii

H

Hook S-53

Self-Service Spares Kit/parts S-54, S-58
Tape-In Module S-8
Vacuum Filters S-14
Overview of Components S-2

P

Pick and Place Head
aligning S-33
ordering S-38

"I don't see Jabberwocky in here. It should be here."

Let us know about the items you can't find by e-mailing:
userdocs@dataio.com.

I

I/O Board S-54, S-58
Interconnect Panel S-44
Interface Manifold S-34

L

Lower Cover, removing S-5

M

Manifold
pneumatic S-14
Modules
replaceable S-1
Mounting Hook S-53

O

Order Form
Basic Spares Kit/parts S-52, S-56
Control Panel Module S-30
Conveyor Belt Module S-22
Cover Tape Module S-20
Covers S-4
Linear Stage Module S-48
Pneumatic Module S-14
PNP head S-38
Programmer Module S-42
Reject Bin S-28

removing S-38 to S-39
Pick and Place Head Cover, removing S-5
Pick delay time S-35
Pick Sensor. See End-of-Belt Sensor
Pneumatic Module
adjusting. See Probe, vacuum sensor.
reinstalling S-18
removing S-16
Probe
balancing speed S-33
position sensor, adjusting S-37
speed specification S-34
speed, adjusting S-33
vacuum sensor, adjusting S-36
Probe Tip, replacing S-53, S-57
Programmer Module
alignment S-45
alignment tool S-45
description S-42
reinstalling S-45
removing S-43
Puff duration S-35

R

Reject Bin
bracket S-29
full sensor S-28
sensor removal S-29
Robot I/O Board S-54, S-58

S

Safety

- grounding iii
- precautions iii

Self-Service Spares Kit

- Memory S-54
- Microcontroller S-58
- ordering parts S-54, S-58

Serial Number

- location S-3

Service

- component overview (figure) S-2
- replacing assemblies S-1

Socket Adapter

- wear S-42

Spare parts S-54, S-58

- locating S-52, S-56
- ordering S-52, S-56

Standard Tape-In Module. See, Tape-In Module.

T

Tape-In Module

- aligning S-12
- jamming S-8
- ordering parts S-8
- removing S-11

Throughput S-33

Training S-55, S-59

Travel delay time S-35

Tube fittings S-16

V

Vacuum Sensor (Probe), adjusting S-36

W

Warning

- electrical shock S-5

Sales and Technical Support



World Wide

Data I/O Corporation
6464 185th Avenue N.E., Suite 101
Redmond, WA USA 98052



Telephone: 425-881-6444
 inside US 1-800-332-8246
Fax: 425-867-6972
E-mail: support@dataio.com

Contact Data I/O World Wide Support or your local representative. To find your local representative on our Web site, go to <http://www.dataio.com> and click **Contact Us** (upper right), then click **Representative Search** (left side). Then follow the instructions.

www.dataio.com	www.dataio.com.cn	www.dataio.de	www.data-io.co.jp
 United States	 China	 Germany	 Japan

When calling or writing, please provide the following information:

- RoadRunner Serial number
- Software Version displayed on the keyboard screen at start-up (turn the power off and then on again)
- Detailed description of the problem you are experiencing (if any)
- Error messages (if any)
- Device manufacturer, part number, package style and number of pins (if device-related)
- Name, telephone number and address