

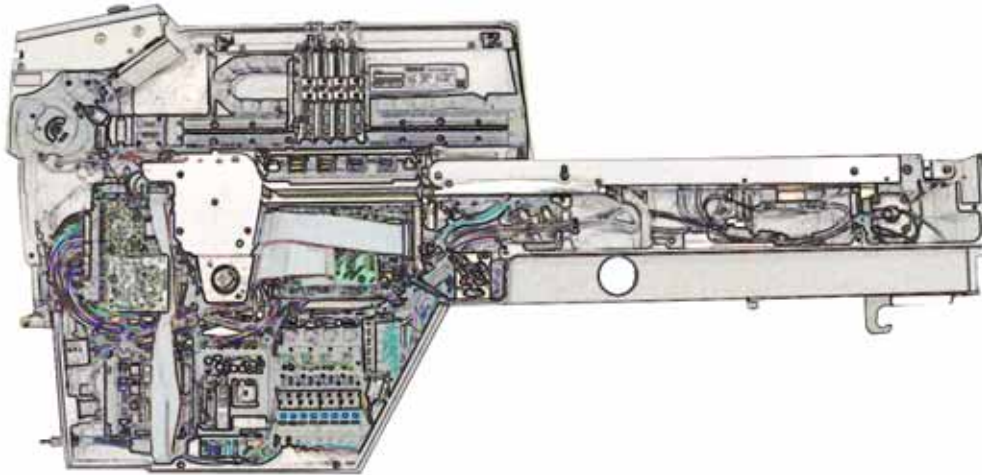

Service



Non-service
information
is in the
**ProLINE-
RoadRunner
Owner's
Manual**

ProLINE-RoadRunnerTM Service Manual

for Panasonic MSF, MCF, MPA



PN 096-0248-001

Data I/O has attempted to ensure that the information in this document is accurate and complete. Data I/O assumes no liability for errors, or for any incidental, consequential, indirect, or special damages, including, without limitation, loss of use, loss or alteration of data, delays, or lost profits or savings, arising from the use of this document or the product which it accompanies.

No part of this document may be reproduced or transmitted in any form or by any means, electronic or mechanical, for any purpose, without written permission from Data I/O Corporation. Data I/O order forms may be reproduced for internal use only.

Data I/O is a registered trademark of Data I/O Corporation.

TaskLink is a trademark of Data I/O Corporation.

ProLINE-RoadRunner is a trademark of Data I/O Corporation.

Data I/O Corporation acknowledges the trademarks of other organizations for their respective products or services mentioned in this document.

Data I/O Corporation also acknowledges the RoadRunner team members for their efforts and for supporting the flow of information into this manual.

We are interested in your comments. email: userdocs@dataio.com

© 2004 Data I/O Corporation

All rights reserved

Table of Contents



096-0248-001

For non-service information see the Owner's Manual, 096-0240.

Precautions for Safe Operation iii

Replaceable Modules P-1

Components Overview P-2

Component List P-3

Covers P-4

Removing the Robotics Cover P-5

Removing the PNP Head Cover P-5

Removing the Lower Cover P-5

Removing the Conveyor Dust Cover P-6

Removing the Conveyor Module Cover P-6

Tape-In Module P-8

Removing the Adjustable Tape-In Module P-9

Removing the Standard Tape-In Module P-11

Pneumatic Module P-14

Replacing the Vacuum Filters P-15

Removing the Pneumatic Module P-16

Reinstalling the Pneumatic Module P-18

Cover Tape Module P-20

Removing the Cover Tape Module P-21

Conveyor Module P-22

Removing the Communications Cable P-23

Removing the Conveyor Module P-24

Adjusting the End-of-Belt Sensor P-25

Reject Bin P-28

Removing the Reject Bin Sensors P-29

Control Panel Module P-30

Removing the Control Panel Module P-31

Pick and Place Head	P-33
Aligning the PNP Head	P-33
Adjusting and Balancing Probe Speed	P-33
Resetting the Pick Delay and Travel Delay Times	P-35
Adjusting Probe Vacuum Sensors	P-36
Removing the PNP Head	P-38
Programmer Module	P-40
Removing the Programmer Module	P-41
Linear Stage Module	P-46
Removing the Linear Stage Module	P-47
Basic Spares Kit, Memory RoadRunner	P-50
Replacing the Probe Tips	P-51
Replacing the Air Inlet Tube Assembly	P-51
Self-Service Spares Kit, Memory RoadRunner	P-52
Basic Spares Kit, Microcontroller RoadRunner	P-54
Replacing the Probe Tips	P-55
Replacing the Air Inlet Tube Assembly	P-55
Self-Service Spares Kit, μcontroller RoadRunner	P-56
Socket Adapter, Actuator, and Precisor	P-58
Alphabetical Index	Index-1

Precautions for Safe Operation

The RoadRunner System has been designed for safe and efficient operation. **The system can be dangerous if the RoadRunner safety features and precautions in this manual are ignored.**



Electrostatic Discharge

The circuit boards inside RoadRunner are susceptible to electrostatic discharge (ESD), which can damage the circuitry. Also, devices processed through the RoadRunner are very sensitive to static and can be damaged by accidental electrostatic discharge while being handled.

The easiest way to prevent damage from ESD is to make sure a common static potential (ground) exists between static-sensitive devices or components, their environment, and the operator.

Perform all repairs at an ESD-safe workstation.

To avoid possible personal injury or damage to the equipment, please observe the following practices:

- Only **trained personnel** should install, maintain, repair, or troubleshoot this system.
- Do not operate the ProLINE-RoadRunner unless you have been thoroughly trained, and have **read and understand the instructions** in this manual, particularly those that describe the system's safety features.
- Do not use ProLINE-RoadRunner for any application other than its **intended use**.
- Do not operate the system if the **guards or safety devices** are not in their normal operating positions.
- Do not operate RoadRunner with any of the **outer sheet metal panels** removed.
- Do not operate RoadRunner while servicing, replacing, or adjusting any component unless directed to do so in this manual. Make sure that the RoadRunner is **properly shut down** before performing any of these operations.
- Do not place any part of your body near or in the direct path of **moving parts**.
- **Do not disable** or attempt to defeat any of the protective safety features of this system. Personal injury or equipment damage can occur if any safety systems on RoadRunner are disabled. If you suspect that a safety feature of the RoadRunner is damaged or malfunctioning, stop using the RoadRunner immediately and contact Data I/O Customer Service or a local Data I/O approved service representative.
- Use extra caution when working around the RoadRunner's Output Belt. RoadRunner's safety shields do not cover or fully enclose the **output conveyor**. It is possible that an operator's hands, other body parts, or loose clothing can get caught or pinched in it.
- Wearing **hearing protection** is recommended while operating the RoadRunner. Sound pressure levels may exceed 85 decibels.
- Shut off the **pressurized air** or disconnect the air hose before servicing pneumatic parts.

Blank page.



Service—Panasonic

Many modules and components on RoadRunner are designed to be serviced or replaced by qualified technicians. You may wish to keep backup modules or components for replacements. The replaced module or component may be sent to Data I/O for repair or adjustment.

Replaceable Modules

Replaceable modules include:

- Tape-In Module
- Conveyor Module
- Control Panel Module
- Linear Stage Module (with PNP Head)
- Pneumatic Module
- Cover Tape Module
- PNP Head (subassembly)
- Programmer Module

Some components can be replaced or adjusted at the customer location. Replacement and adjustment procedures for those components are included in this chapter. Some modules can be removed and sent to Data I/O or a local representative for servicing or exchanging.

Within each main section of this chapter is an order form with relevant Model Names. These names represent the RoadRunner configuration at the time of printing this manual only, and may not be the same as your unit. However, the Model Names will always get you the latest interchangeable replacement.



Tools required for RoadRunner maintenance are listed in “Tools Required” in Chapter 5 of the Owner’s Manual.

Some of the tools required are • Metric hex keys (Allen wrenches), • a volt meter or multi-meter, • and a metric scale or calipers.

CAUTION: *Electrostatic discharge may damage parts. Before servicing, place the RoadRunner on an ESD-safe workstation.*

Components Overview

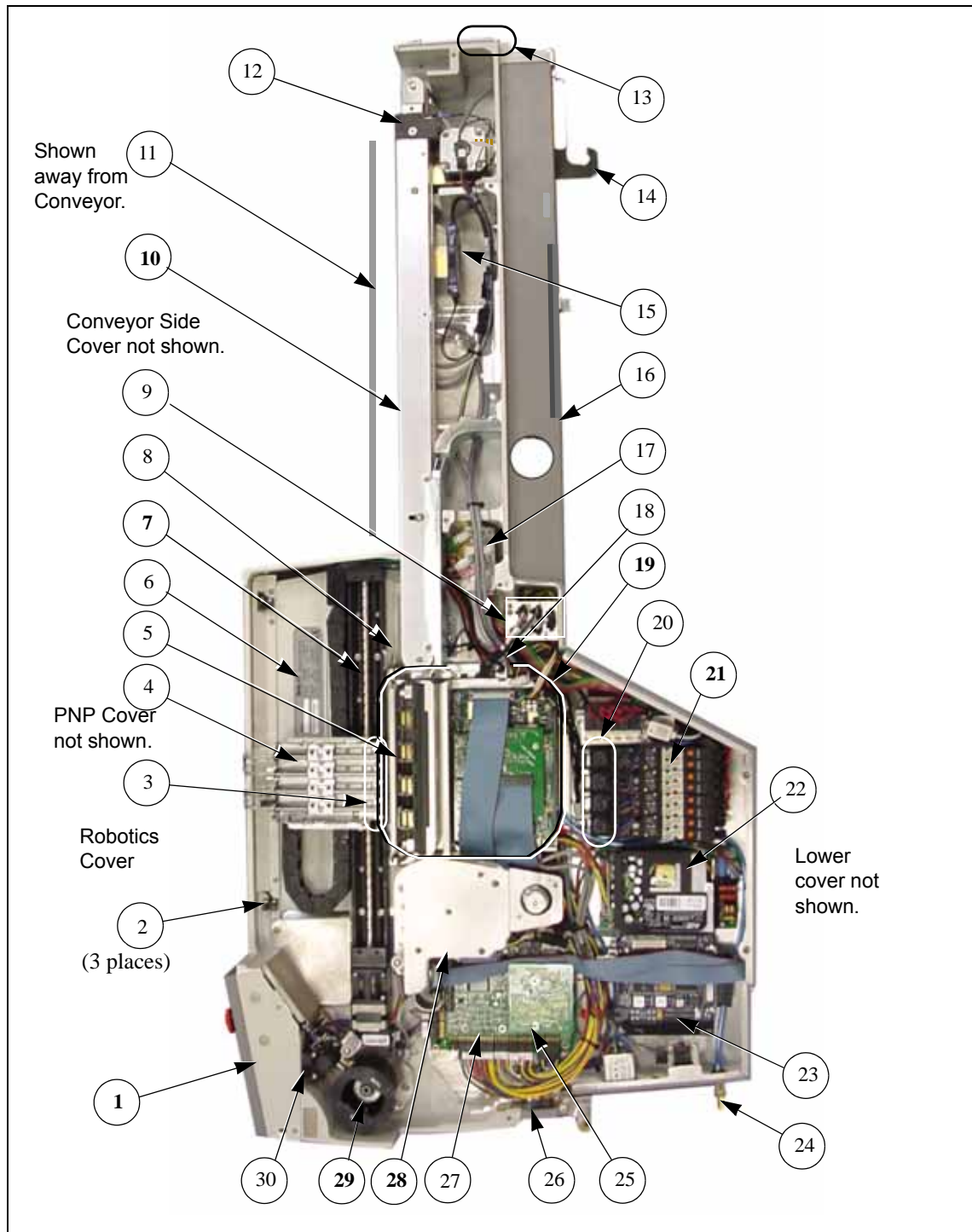

Figure P-1—Component Overview

CAUTION: Place RoadRunner on an ESD-safe workstation.
CAUTION: To prevent damage when unplugging cables, pull the connector and not the wires.

4P

P

Component List



Modules are listed in bold type.

1. **Control Panel Module**, [page P-30](#)
2. Head Limit Sensors
3. Rubber Probe Tips
4. Pick and Place (PNP) Head
5. Socket Adapter
6. Serial Number Label
7. **Linear Stage Module**, [page P-46](#)
8. Reject Bin
9. Interconnect Panel
10. **Conveyor Module**, [page P-22](#)
11. Conveyor Dust Cover
12. End-Of-Belt Sensor Optic
13. SMT Communication Connection
14. Mounting Guide Bar
15. End-Of-Belt Sensor Controller
16. Tape Exit
17. Interface Manifold
18. Socket Actuator Sensor
19. **Programmer Module**, [page P-40](#)
20. Vacuum Filters
21. **Pneumatic Module**, [page P-14](#)
22. Power Supply
23. Motion Controller PCB
24. Air inlet connection
25. SMT Communications PCB
26. Power Switch
27. Robot I/O PCB
28. **Tape-In Module**, [page P-8](#)
29. **Cover Tape Module**, [page P-20](#)
30. Robotics-Cover-Open Sensor



CAUTION: *Electrostatic discharge may damage parts. Before repair work begins, place the RoadRunner on an ESD-safe workstation.*

Covers

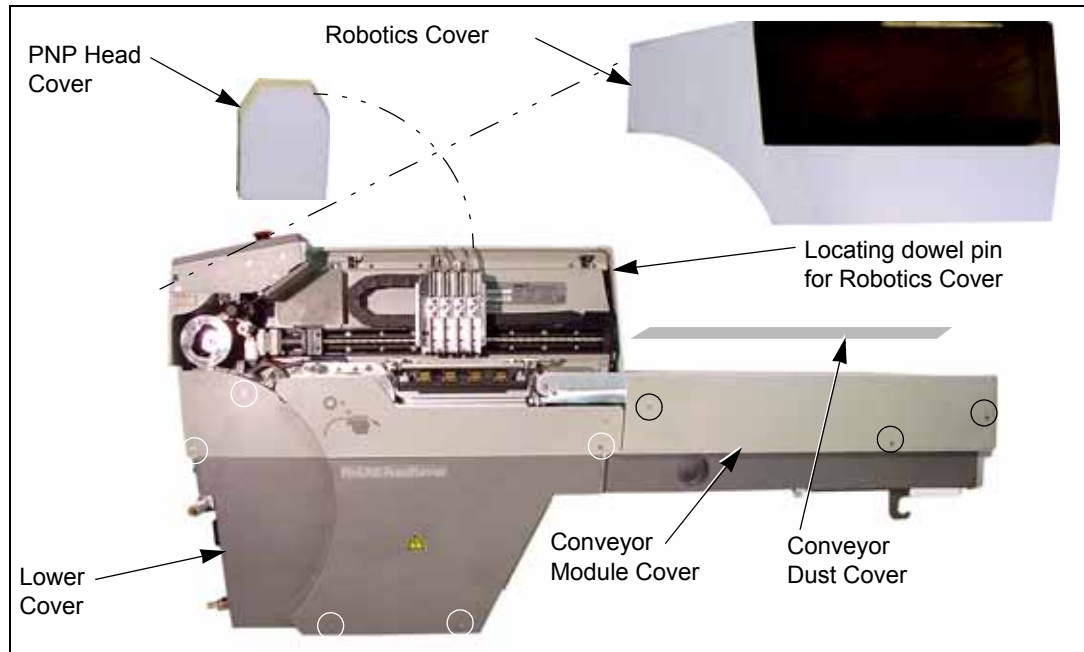

Figure P-2—Covers (with Screw Locations Indicated by Circles)

The RoadRunner has five removable covers:

- Robotics Cover
- PNP Head Cover
- Lower Cover
- Conveyor Dust Cover
- Conveyor Module Cover

The Robotics Cover shields the tape path and the programmer.

Data I/O Parts Ordering Information

Instructions: 1. Copy this page. 2. Fill in your RoadRunner model and serial numbers (see the label on the chassis under the Robotics Cover). 3. Fill in the quantity for the item(s) desired. 4. Call Data I/O, or visit our Web site, for part prices (optional). 5. Mail or FAX it with your purchase order to Data I/O. See the last page of this manual for contact information.

ProLINE-RoadRunner Model No. _____ Serial No. _____

Model Name	Part Description	Qty	Price Ea.	Totals
RR-ROBOTICS COVER - F,U,A	Robotics Cover		\$	\$
COVER PNP	PNP Head Cover		\$	\$
RR-LOWER COVER	Lower Cover		\$	\$
RR-COVER DUST-U OR A	Conveyor Dust Cover		\$	\$
RR-COVER CONVEYOR-U OR A	Conveyor Module Cover		\$	\$
			\$	\$

Signature: _____ Date: _____ Company: _____

Removing the Robotics Cover

Grasp the outer edges of the Robotics Cover and gently pull away from the Control Panel and out.

There is a locating dowel pin on the end opposite the Control Panel Module.

NOTE: The Robotics Cover can be removed while the RoadRunner is running. However, the robot speed reduces by 50%.

WARNING

Shock Warning. Do not remove the Lower Cover or the Conveyor Module Cover while the RoadRunner is plugged in.

Removing the PNP Head Cover

The PNP Head Cover is magnetically attached to the head and pulls off.

To replace it, set it over the head and rock it until the metal ridges on the inside of the cover seat into notches on the head.

Removing the Lower Cover

1. Turn the power off.
2. Disconnect the RoadRunner power cord and air supply.

NOTE: The RoadRunner pressurized air supply tube has a quick disconnect fitting with an automatic shut off. The line may be disconnected without shutting off the supply line air pressure.



For screw locations see Figure P-2.

3. Remove the Robotics Cover.
4. Remove the five screws that hold the Lower Cover to the chassis.
5. Slide the cover up (toward the Control Panel) to unhook a clip in the lower left corner, then lift off. See [Figure P-3](#).

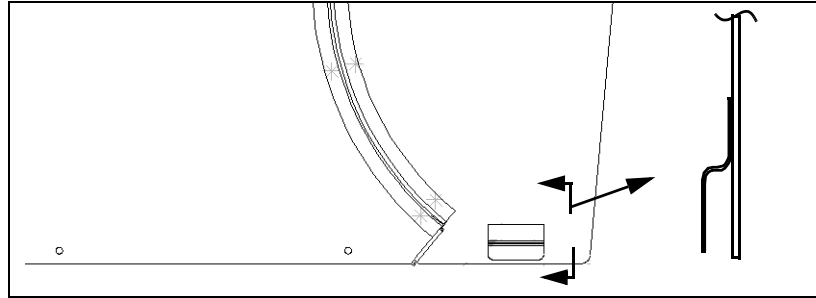

Figure P-3—Detail of Clip on the Inside of the Lower Cover

Removing the Conveyor Dust Cover

The Conveyor Dust Cover lifts off two dowel pins.

Removing the Conveyor Module Cover

1. Turn the power off.
2. Disconnect the RoadRunner power cord and air supply.
3. Remove the three screws that hold the Conveyor Module Cover to the chassis.



For screw locations see
[Figure P-2](#).

Blank page.

4P

P

Tape-In Module

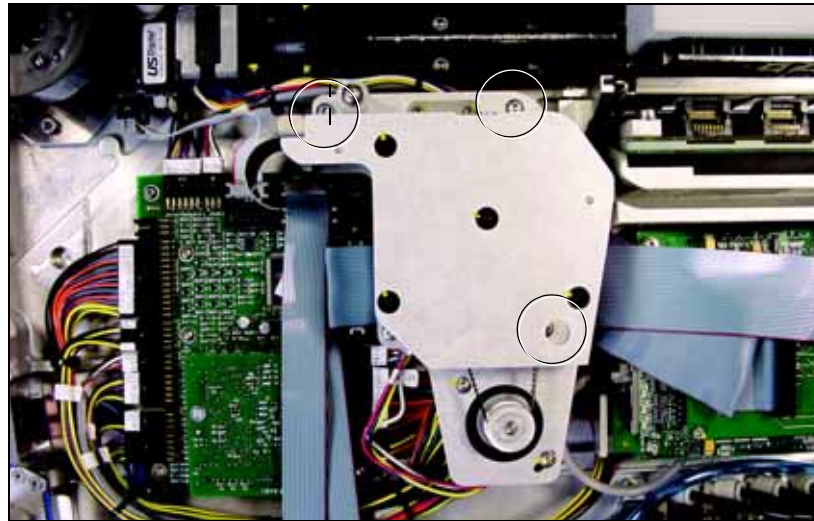

Figure P-4—Location of Tape-In Module Screws (circled)

The Tape-In Module uses a sensor to determine if the cover tape is present or broken, and another to send sprocket motion feedback to the system controller. The Tape-In Module advances the device tape.

If the device tape is jamming in the sprocket or tape path, there could be a problem with the Tape-In Module. Refer to the Troubleshooting chapter to identify the problem. If the problem is the Tape-In Module, remove it and return it to Data I/O for repair or replacement. If your RoadRunner is past warranty period, you may elect to repair it on-site if you have a certified technician.

Two sensors on the far side of this module can be replaced independently.

Data I/O Parts Ordering Information

Instructions: 1. Copy this page. 2. Fill in your RoadRunner model and serial numbers (see the label on the chassis under the Robotics Cover). 3. Fill in the quantity for the item(s) desired. 4. Call Data I/O, or visit our Web site, for part prices (optional). 5. Mail or FAX it with your purchase order to Data I/O. See the last page of this manual for contact information.

ProLINE-RoadRunner Model No. _____ Serial No. _____

Model Name	Part Description	Qty	Price Ea.	Totals
RR-16MM TAPEIN KIT	Kit, Tape-In Module, 16mm		\$	\$
RR-24MM TAPEIN KIT	Kit, Tape-In Module, 24mm		\$	\$
RR-32MM TAPEIN KIT	Kit, Tape-In Module, 32mm		\$	\$
RR-ADJUSTABLE TAPE-IN KIT	Kit, Adjustable Tape-In Module		\$	\$
RR-SLOT SENSOR CAB	Tape Advance Sensor (Cable Assy)		\$	\$
RR-SLOT SENSOR CAB	Cover Tape Broken Sensor (Cable Assy)		\$	\$
ASSY,TAPE IN,RR-uC	Kit, Tape-In Module, Microcontroller		\$	\$

Signature: _____ Date: _____ Company: _____

Removing the Adjustable Tape-In Module

(For the Standard Tape-In Module, see page P-11.)

1. Turn the power off.
2. Disconnect the RoadRunner power cord and air supply.
3. Remove the Robotics Cover and Lower Cover.
4. Remove the two screws attaching the Tape Guide to the Adjustable Tape-In (ATI) Module.

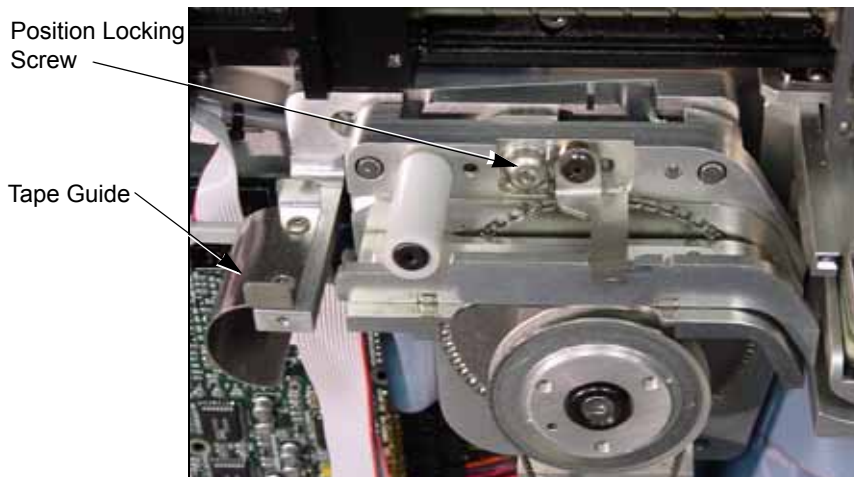

Figure P-5—The Adjustable Tape-In Module

5. Unscrew the Position Locking Screw and lift the subassembly away from the Base as far as the wires allow.
6. Check that wire labels are clearly marked and unplug the wires for the Tape Advance Sensor, the Cover Tape Broken Sensor, and the Tape-In Motor.

NOTE: The two sensors are the same—where they plug in determines their function.

The sensors may be replaced independently of the module.

7. Remove the three screws that attach the ATI Base to the chassis. See the figure below.



Figure P-6—Adjustable Tape-In Module Base

8. Lift the Base from the chassis.

Replacement is in the reverse order of removal with these precautions:

- Ensure that cable connectors are mated correctly.
- Ensure that no wires or hoses get pinched.
- If you are installing a Tape-In Module other than the one you removed, you need to align it to the PNP Head by performing the alignment procedure. (See next heading.)

Aligning the Adjustable Tape-In Module

To center the tape path under the PNP probes:

1. Load a piece of empty device tape into the Adjustable Tape-In (ATI) Module.
2. Move the PNP Head so that Probe 1 is directly over the pick point.
3. Remove the PNP Head Cover by pulling it off.
4. Remove the rubber Probe Tip from Probe 1.
5. Extend Probe 1 fully by pushing down on the block below the spring to visually compare the position of the hole in the center of the tape pocket to the probe.

If the probe is centered over the hole, then the tape path is centered. Replace the Probe tip; you are done centering the tape path. Otherwise continue.

6. Loosen the Position Locking Screw.

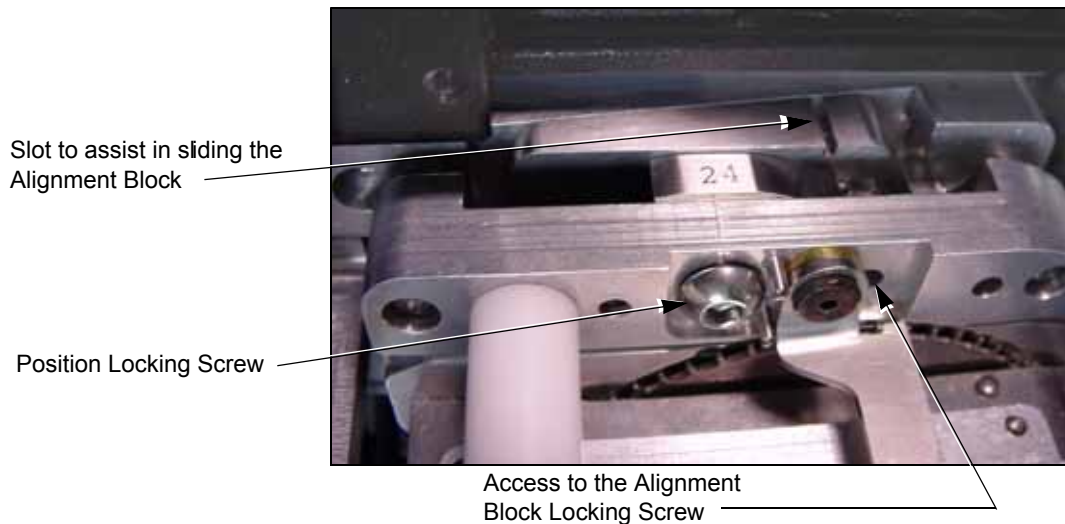

Figure P-7—Aligning the Adjustable Tape-In Module

7. Loosen the Alignment Block Locking Screw with a 2 mm Allen Wrench. A small access hole is provided.
8. Slide the Alignment Block left or right as needed to bring the device tape in-line with the probe. A slot in the top of the Alignment Block accommodates a flat screwdriver to assist in sliding the block.
9. Tighten the Position Locking Screw.
10. Recheck alignment.
11. Tighten the Alignment Block Locking Screw.
12. Replace the Probe Tip.
13. Replace the PNP Head Cover.

4P

Removing the Standard Tape-In Module



For more information, see “Covers” on page P-4.

For the location of the chassis screws see Figure P-4.

1. Turn the power off.
2. Disconnect the RoadRunner power cord and air supply.
3. Remove the Robotics Cover and Lower Cover.
4. Remove the three or four screws (depending on your model) that connect the Tape-In Module to the chassis.
5. Lift the Tape-In Module from the chassis as far as wires will allow.

NOTE: The 16mm and 24mm Tape-In Modules have spacers that could fall out. They must be saved and reused on reinstallation.

6. Check that wire labels are clearly marked and unplug the wires for the Tape Advance Sensor, the Cover Tape Broken Sensor, and the Tape-In

P

Motor.
The sensors may be replaced independently of the module.

NOTE: The two sensors are the same—where they plug in determines their function.

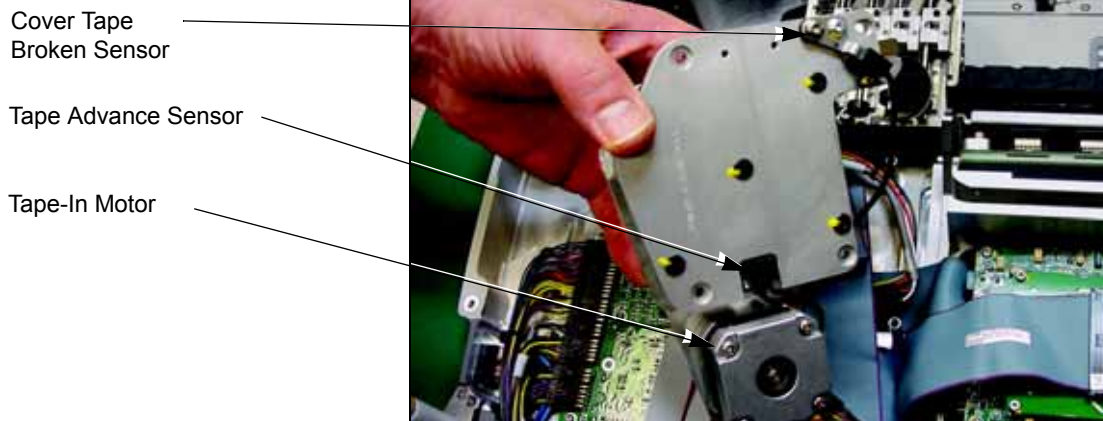

Figure P-8—Location of Sensors and Motor on the Tape-In Module

- 6a. To replace the Tape Advance Sensor or the Cover Tape Broken Sensor, remove the screw attaching the sensor to the module. (The cables have been unplugged from the connector in a previous step.)

Replacement is in the reverse order of removal with these precautions:

- Ensure that cable connectors are mated correctly.
- Ensure that no wires or hoses get pinched.
- Ensure that the Module seats on the standoffs (and spacers—16mm and 24mm Modules).
- If you are installing a Tape-In Module different from the one you removed, you need to align it to the PNP Head by performing the alignment procedure. (See following heading.)

Aligning the Standard Tape-In Module

Some Tape-In Modules are not adjustable. Others are mounted on an adjustable Standoff for alignment purposes. If your model has the Adjustable Standoff, you will see the adjustment stud from the top as you look down at the Tape-In Module as shown in the figure below.

4P

P



Figure P-9—Some Tape-In Modules have an Adjustable Standoff for setting the Alignment with the Probes. The wrench flats and Locknut identify the Adjustment Stud from a non-adjustable Standoff.

To align the Tape-In Module:

1. Loosen the top left and bottom right mounting screws.
2. Loosen the Locknut on the Adjustable Standoff (7 mm wrench).

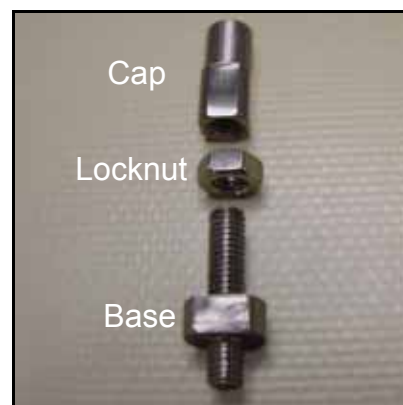

Figure P-10—Adjustable Stud for the Standard Tape-In Module

3. Adjust the Cap of the Adjustable Standoff (6 mm wrench) until the Tape-In Module is in-line with a PNP Probe. To do that:
 - 3a. Place a small piece of device tape on the Tape-In Module.
 - 3b. Remove the rubber tip from Probe 1.
 - 3c. Extend Probe 1 fully by pushing down on the block below the spring.
 - 3d. Adjust the Standoff to visually align the hole in the center of the tape pocket with the probe.
4. Screw the Locknut until it rests tight against the Cap to lock it in place.
5. Tighten the other two mounting screws.
6. Recheck alignment; loosen the Locknut and readjust if necessary.
7. Put the rubber tip back onto Probe 1.

Pneumatic Module

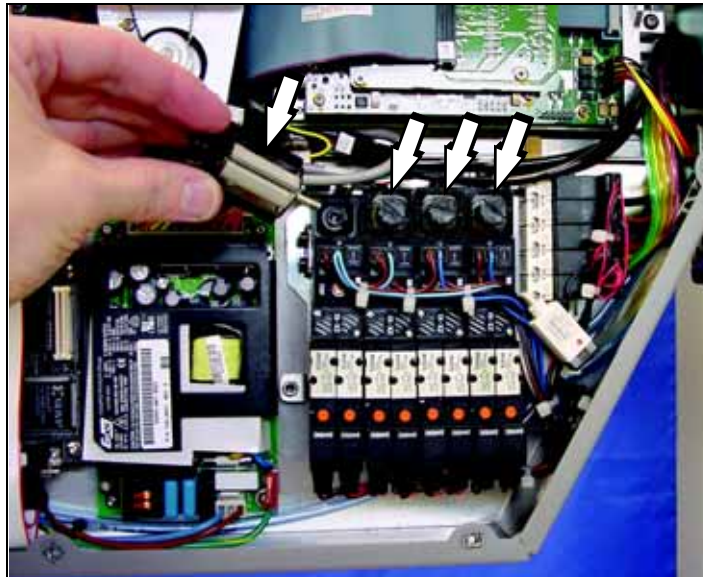

Figure P-11—Pneumatic Module and Vacuum Filter Locations

The Pneumatic Module controls vacuum and blowoff air to the probes, as well as pressurized air to the probe cylinders and programmer socket cylinders.

Pneumatic Module suction is affected by clogged or dirty filters or hoses and by improper connections. If the vacuum filters are clogged or dirty, vacuum sensors have difficulty detecting whether a device is on the probe or not. This can result in error messages such as “Device pick failure at input with probe 1.”

Data I/O Parts Ordering Information

Instructions: 1. Copy this page. 2. Fill in your RoadRunner model and serial numbers (see the label on the chassis under the Robotics Cover). 3. Fill in the quantity for the item(s) desired. 4. Call Data I/O, or visit our Web site, for part prices (optional). 5. Mail or FAX it with your purchase order to Data I/O. See the last page of this manual for contact information.

ProLINE-RoadRunner Model No. _____ Serial No. _____

Model Name	Part Description	Qty	Price Ea.	Totals
RR-VAC FILTER	Vacuum filter		\$	\$
ASSY,PNEUMATIC,MODULE	Pneumatic Module		\$	\$
			\$	\$
			\$	\$
			\$	\$

Signature: _____ Date: _____ Company: _____

If you experience problems such as dropped devices or pick failures, replace the vacuum filters (page P-15), adjust the vacuum sensor (page P-36), or see the chapter on “Troubleshooting” in the Owner’s Manual.

NOTE: In normal low-dust conditions, Vacuum Filters must be replaced every 6 months. Replacement may need to be done more frequently in dustier environments.

Replacing the Vacuum Filters



For more information, see “Covers” on page P-4.

1. Turn the power off.
2. Disconnect the RoadRunner power cord and air supply.
3. Remove the Robotics and Lower Covers.
4. Remove the square plastic housings with the Vacuum Filters by unscrewing the thumbscrews from the valve block.

NOTE: Ensure that the gasket between the housing and the valve block does not fall out during removal or installation of the housing. If it does, install the gasket into the groove on the valve block.

CAUTION: The housing has two locating pins. To prevent damage, orient the housing correctly when reinstalling.

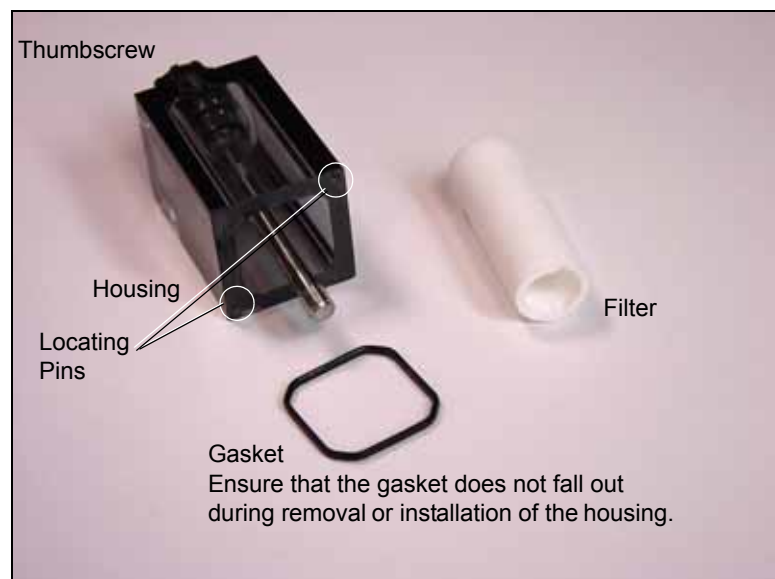

Figure P-12—Vacuum Filter Components

5. Remove the filter from the plastic housing.
6. When installing a new filter, make sure the rubber gasket is in place between the housing and the valve block.

Removing the Pneumatic Module



The RoadRunner pressurized air supply tube has a quick disconnect fitting with an automatic shut off. The line may be disconnected without shutting off the supply line air pressure.



For more information, see “Removing the Lower Cover” on page P-5.



For the location of Probe vacuum lines see Figure P-14.

1. Turn the power off.
2. Disconnect the RoadRunner power cord and air supply.
3. Pull off the Robotics Cover.
4. Remove the Lower Cover.

NOTE: The vacuum lines and air pressure lines must be reinstalled to their same locations. Do not reverse them. Ensure that each line has a label before disconnecting.

5. Disconnect the four vacuum lines on the manifold adjacent to the filters. To release the “One-touch” connector, push the connector sleeve and pull the tube simultaneously. To reconnect, simply insert the tube into the housing sleeve, pushing it all the way in.

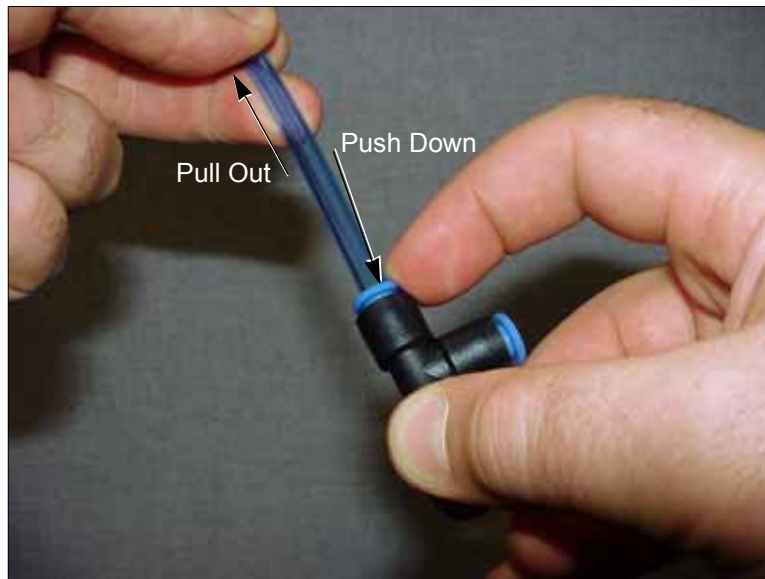

Figure P-13—Disconnecting a Pneumatic Tube from the One-touch Connector

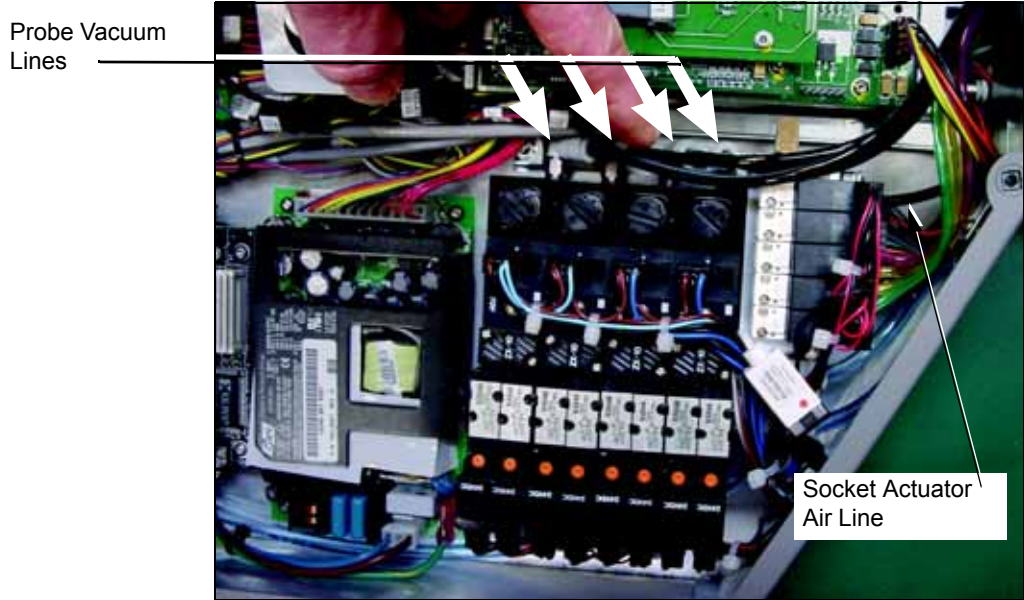

Figure P-14—Location of Vacuum and Air Lines



The Pneumatic access cover, secured with two screws, is on the back housing flange. See [Figure P-15](#).

6. Remove the Pneumatic Access Cover.
7. Disconnect the Pneumatic Manifold Supply Line at the One-touch connector on the manifold.
8. Unscrew the two screws from the 25-pin cable connector and unplug the connector from the manifold bracket.

4P

Probe Air Lines

Pneumatic Manifold Supply Line; One-touch Connector

25-Pin Connector; two 1.5mm Allen fasteners

Access hole to the other fastener

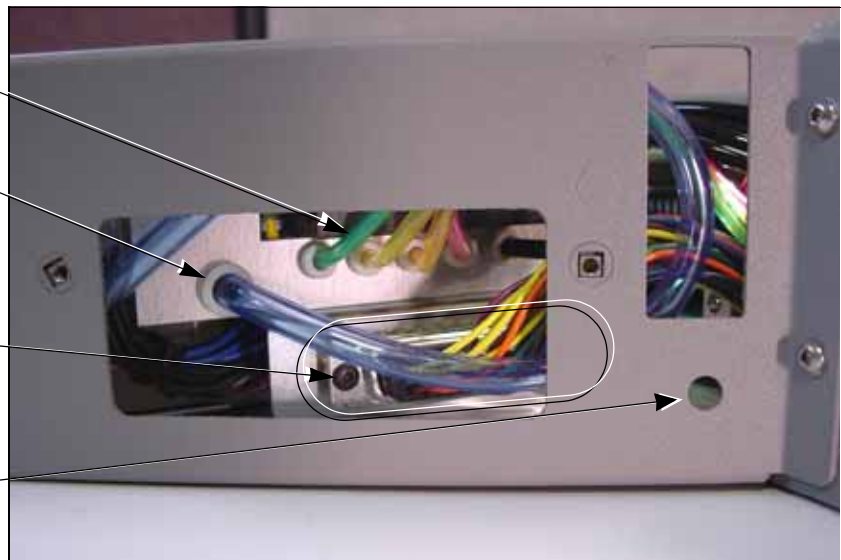

Figure P-15—Location of the Pneumatic Manifold Supply Line and Wiring Connector

P

9. Remove the three screws securing the Pneumatic Module to the RoadRunner chassis.

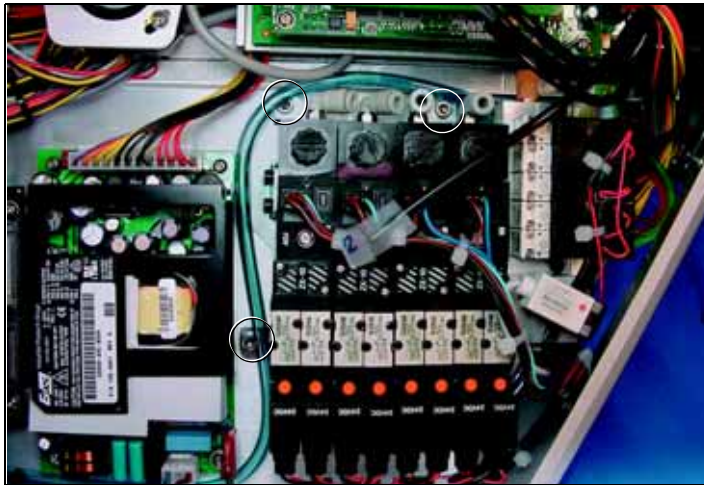

Figure P-16—Pneumatic Module fastener locations. The Probe Vacuum Tubes have been Disconnected.



To identify tubing lines see Figure P-14 and Figure P-15.

10. Lift the Pneumatic Module enough to remove the four Probe Air Tubes and the Socket Actuator Air Tube (one-touch fittings).
11. Lift the Pneumatic Module free from the RoadRunner chassis.

Reinstalling the Pneumatic Module

Installation is done in the reverse order of removal; then the following post-installation adjustments are required:

1. At the Control Panel, verify proper electrical and pneumatic connections as follows:
 - 1a. Extend and retract each probe to verify correct plumbing. *Robot Diagnostics » Probe X » Position » Arrow Up/Down.*
 - 1b. Enable vacuum to each probe to verify correct plumbing. *Robot Diagnostics » Probe X » Vac Sense » Arrow Up/Down.*
 - 1c. Enable probe “Puff” and verify correct switching of positive air pressure at the probe tips. *Robot Diagnostics » Probe 1 » Puff » Up/Down Arrow.*
2. Adjust the probe vacuum sensors.
3. Adjust probe speed.



For step 2 see “Adjusting Probe Vacuum Sensors” on page P-36.

For step 3 see “Adjusting and Balancing Probe Speed” on page P-33.

Blank page

4P

P

Cover Tape Module

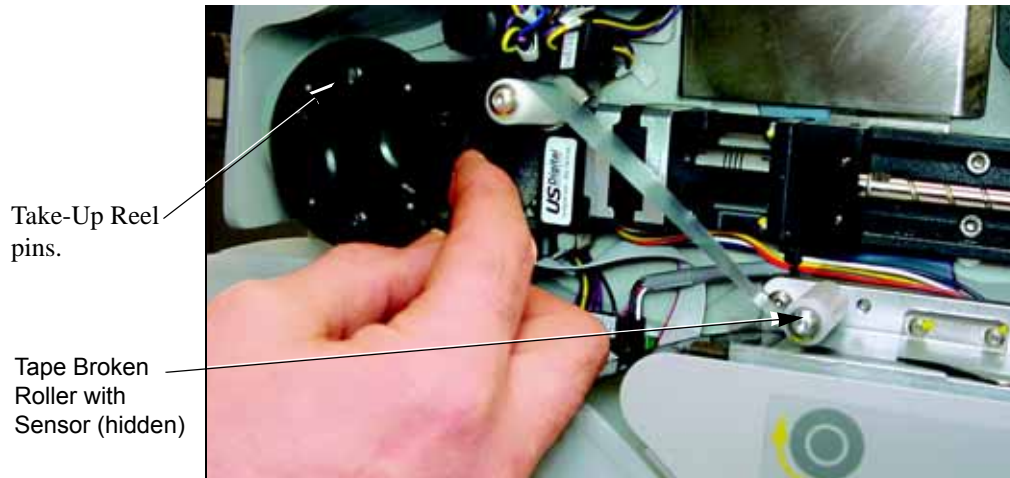

Figure P-17—Cover Tape Tensioning the Tape Broken Roller and Sensor

If the Cover Tape Module fails to wind tape onto the reel, first check to see if the reel is full. Also, check that there is tension against the Tape Broken Roller.

If the Take-Up Reel is not full but the module is not winding tape, then the Cover Tape Module is suspect. Check for these:

- loose reel not seated on the pins
- loose or broken drive belt
- malfunctioning motor,
- malfunctioning clutch assembly, or
- a motor connector that is loose or disconnected.

If the problem is the motor or drive belt, then the Cover Tape Module needs to be replaced and returned to Data I/O for repair. If your RoadRunner is past warranty period, you may elect to repair it on-site if you have a certified technician.

Data I/O Parts Ordering Information

Instructions: 1. Copy this page. 2. Fill in your RoadRunner model and serial numbers (see the label on the chassis under the Robotics Cover). 3. Fill in the quantity for the item(s) desired. 4. Call Data I/O, or visit our Web site, for part prices (optional). 5. Mail or FAX it with your purchase order to Data I/O. See the last page of this manual for contact information.

ProLINE-RoadRunner Model No. _____ Serial No. _____

Model Name	Part Description	Qty	Price Ea.	Totals
RR-COVER TAPE MOD	Cover Tape Module		\$	\$
			\$	\$
			\$	\$
			\$	\$
			\$	\$
			\$	\$

Signature: _____ Date: _____ Company: _____

Removing the Cover Tape Module

1. Turn the power off.
2. Unplug the RoadRunner power cord.
3. Remove the Robotics Cover.
4. Remove the tape reel from the Cover Tape Module.
5. Remove the three screws that mount the Cover Tape Module to the RoadRunner chassis.

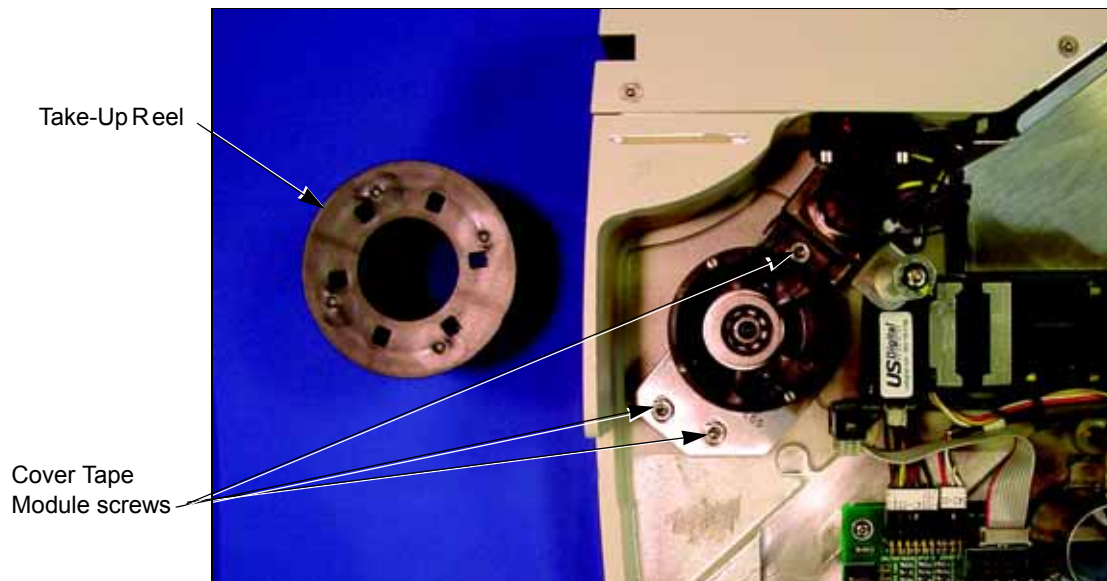

Figure P-18—Location of the Cover Tape Module Mounting Screws (with the Reel Removed)

6. Disconnect the cable from the Cover Tape Module motor.

Replacement of the Cover Tape Module is done in reverse order of removal.

NOTE: There are two styles of Take-Up Reel. One has six holes (shown) and snaps onto the hub, the other has two slots that you fit over pins on the hub and twist into place. Use only the Take-Up Reel appropriate for your hub.

Conveyor Module

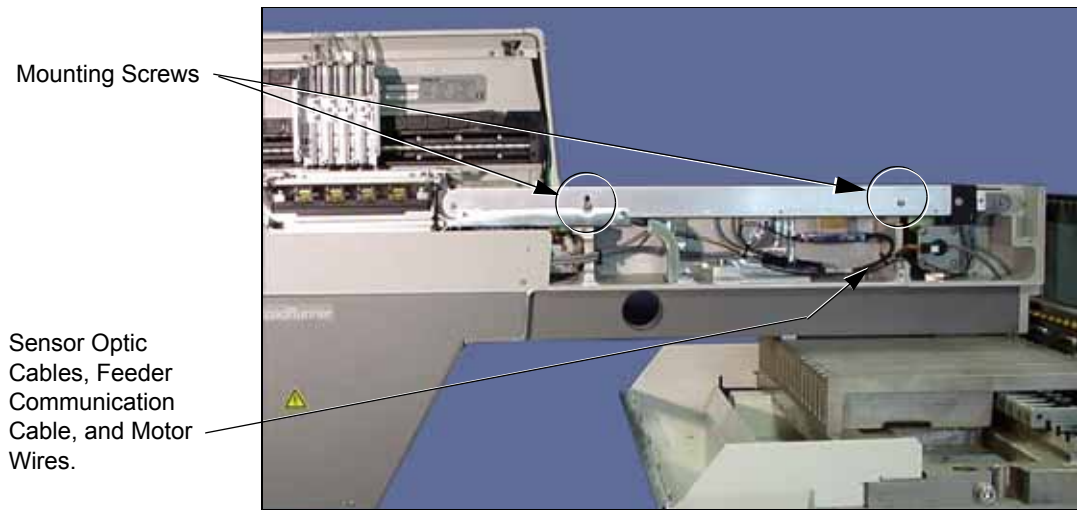

Figure P-19—Location of Wires and Screws on the Conveyor Module

The conveyor belt, the belt motor, and the End-of-Belt Sensor make up the main parts of the Conveyor Module.

If the conveyor belt becomes creased, it will cause devices placed on the crease to be mispositioned. For this reason, a Conveyor Module with a creased or damaged belt should be immediately replaced.

The entire Conveyor Module can be removed and replaced or sent to Data I/O for repair. The End-of-Belt sensor optic can be adjusted and the sensor controller retight.

Data I/O Parts Ordering Information

Instructions: 1. Copy this page. 2. Fill in your RoadRunner model and serial numbers (see the label on the chassis under the Robotics Cover). 3. Fill in the quantity for the item(s) desired. 4. Call Data I/O, or visit our Web site, for part prices (optional). 5. Mail or FAX it with your purchase order to Data I/O. See the last page of this manual for contact information.

ProLINE-RoadRunner Model No. _____ Serial No. _____

Model Name	Part Description	Qty	Price Ea.	Totals
RR-ASSY CONV, PANA	Conveyor Module		\$	\$
CABLE ASSY, COMM, PANA	Feeder Communication Cable Assy		\$	\$
ASSY,CONVEYOR 16MM,PANA-SONIC,RR-uC	Conveyor Module, Microncontroller		\$	\$
			\$	\$

Signature: _____ Date: _____ Company: _____

Removing the Communications Cable



See “Removing the Conveyor Module Cover” on page P-6.

1. Turn the power off.
2. Disconnect the RoadRunner power cord and air supply.
3. Lift off the Conveyor Dust Cover.
4. Remove the Conveyor Module Cover.
5. Remove the screw securing the Pin Block to the chassis.
6. Unplug the Feeder Communications Cable connector.

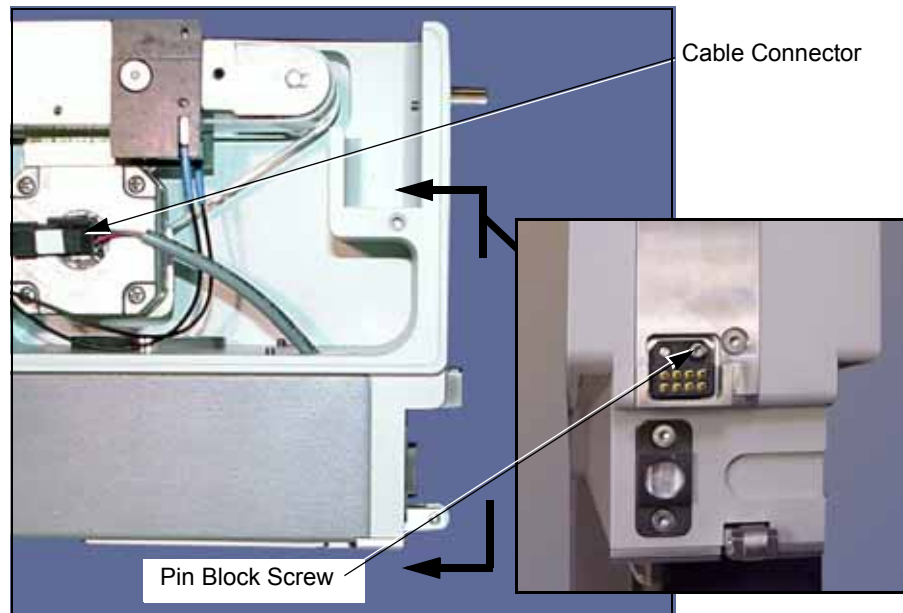

Figure P-20—Feeder Communications Cable

7. Pull the Pin Block out while carefully threading the connector through the chassis until the cable assembly is free.

4P

P

Removing the Conveyor Module



For more information, see “Removing the Conveyor Module Cover” on page P-6.

1. Turn the power off.
2. Disconnect the RoadRunner power cord and air supply.
3. Lift off the Conveyor Dust Cover.
4. Remove the Conveyor Module Cover.
5. Cut the tie wraps securing the wires for the belt motor, communications, and sensors.

CAUTION: Optic cables are fragile and may break. Do not bend radically.

6. Disconnect two connectors: belt motor wires and sensor controller wires.



Figure P-21—Conveyor Wire Connector Locations (Circled)



For Conveyor screw locations see Figure P-19.

7. Remove the two screws attaching the Conveyor Module to the chassis.
8. Lift the Conveyor Module free of the RoadRunner chassis.

Reinstalling the Conveyor Module

To reinstall the conveyor, reverse the removal steps, plus perform the following:

1. Notice the locating pin on the chassis for location.
2. Set the conveyor height as follows:
 - 2a. With the RoadRunner in its normal upright position and the conveyor fasteners in but not tightened, move the PNP Head over the conveyor belt.
 - 2b. Place your thinnest device on the belt below Probe 1.
 - 2c. Lower Probe 1 fully (pushing on the block below the spring). Adjust the conveyor height so that the probe tip just barely contacts the device on the belt, then tighten the fasteners.
 - 2d. Recheck the height after tightening the fasteners.



Push probe here with finger.

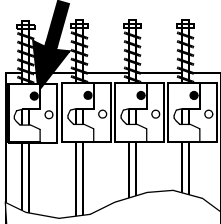

Adjusting the End-of-Belt Sensor

The End-of-Belt Sensor Optic stops the conveyor belt when parts reach the pick point. The optic functions by sending a beam across the pick point between two fiber optic sensors. When a device breaks the beam, the End-of-Belt Optic stops the belt. The most likely indication that the End-of-Belt Optic is out of adjustment or broken, is that parts fall off the end of the conveyor.

If parts are falling off the end of the conveyor, first test to make sure the sensor controller is functioning (see below). If the sensor is functioning, but parts are still passing the pick point, reattach the sensor controller.

Testing the End-of-Belt Sensor

1. From the top level menu select *Robot Diagnostics*.
2. Select *Belt*.
3. Select *Pick Sensor*.
4. Put your finger at the SMT pick point to block the sensor optic.
5. The Control Panel display will show *Pick Sensor: 1* whenever your finger is blocking the beam, and *Pick Sensor: 0* when not blocked.



Figure P-22—Testing the End-of-Belt Sensor (The Conveyor Cover need not be removed.)

6. If *Pick Sensor: 1* is not displayed when the beam is blocked, check to make sure that all the sensor wires and fiber optics are connected properly.
 - 6a. If *Pick Sensor: 1* still does not display, then the Conveyor Module needs to be replaced.
 - 6b. If *Pick Sensor: 1* does display, see “Reteaching the End-of-Belt Sensor Controller,” below.



The controller is mounted to the chassis under the Conveyor Module.

Reteaching the End-of-Belt Sensor Controller

1. Lift off the Conveyor Dust Cover.

2. Remove the Conveyor Module Cover.
3. Press the Emergency Stop button—the conveyor belt can now be rotated by hand.
4. Clean the conveyor belt. With isopropyl alcohol on a lint-free cloth, clean the exposed portion of the belt and then dry it. Rotate the belt and repeat.
5. Manually rotate the belt so that the sensor controller displays its highest value.
6. Place a device on the SMT pick point so it blocks the optic beam.
7. Push *Set* on the sensor controller.

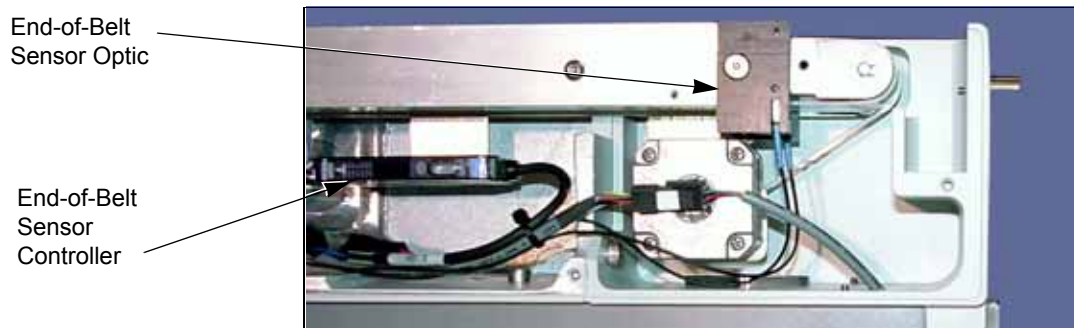

Figure P-23—Retaching the End-of-Belt Sensor

8. Remove the device from the belt and then rotate the belt until the sensor controller displays its lowest value.
9. Push *Set* on the sensor controller again.

NOTE: In general, the End-of-Belt Sensor Controller should display a number less than 21 when a device is present at the SMT pick point and greater than 90 when no device is present. If it is not possible to achieve numbers less than 21 and greater than 90 by adjusting the optic beam, the conveyor module must be replaced. (The Sensor Controller must always operate in “Turbo” mode.)



For details on setting the Sensor Controller see the label on the inside of the Conveyor Cover.

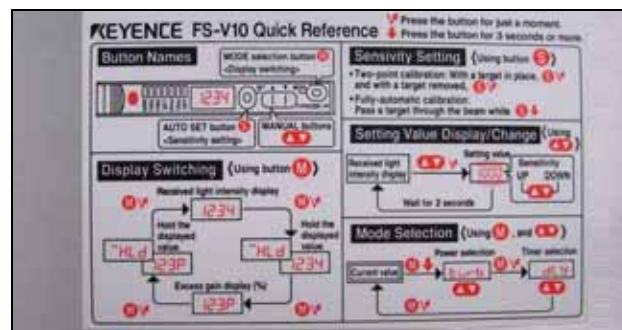

Figure P-24—End-of-Belt Sensor Controller Label on the Conveyor Cover

Blank page

4P

P

Reject Bin

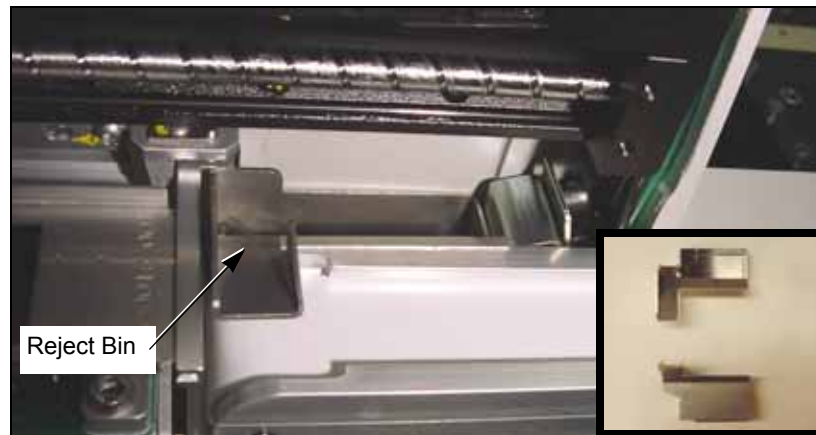

Figure P-25—The Reject Bin

The Reject Bin is not fastened in, and lifts out of the RoadRunner. Lift up and then out.

The Reject Bin-Full Sensor senses when the bin is full and requires emptying. The Reject Bin-Present sensor senses when the bin is not in place. They are attached to the reject bin bracket.

4P

Data I/O Parts Ordering Information

Instructions: 1. Copy this page. 2. Fill in your RoadRunner model and serial numbers (see the label on the chassis under the Robotics Cover). 3. Fill in the quantity for the item(s) desired. 4. Call Data I/O, or visit our Web site, for part prices (optional). 5. Mail or FAX it with your purchase order to Data I/O. See the last page of this manual for contact information.

ProLINE-RoadRunner Model No. _____ Serial No. _____

Model Name	Part Description	Qty	Price Ea.	Totals
RR-REJECT BIN	Reject Bin		\$	\$
RR-REJECT BIN SENS	Reject Bin-Full Sensor		\$	\$
RR-SLOT SENSOR CAB	Reject Bin-Present Sensor		\$	\$
ASSY,REJECT BIN,RR-uC	Reject Bin, Microncontroller		\$	\$
			\$	\$

Signature: _____ Date: _____ Company: _____

P

Removing the Reject Bin Sensors



For more information, see “Removing the Conveyor Module” on page P-24.

1. Turn the power off.
2. Disconnect the power cord and air supply.
3. Lift off the Robotics Cover.
4. Push the head away from the programmer.
5. Remove the Lower Cover.
6. Remove the Conveyor Module screws (the wires do not need to be unplugged) and lift it out of the way.
7. Lift out the Reject Bin.
8. Unplug the sensor wire connectors J1C and J1C2 from the Interconnect Panel. Cut wire ties as necessary.
9. Remove three socket head screws securing the Reject Bin Bracket to the chassis and lift it out.

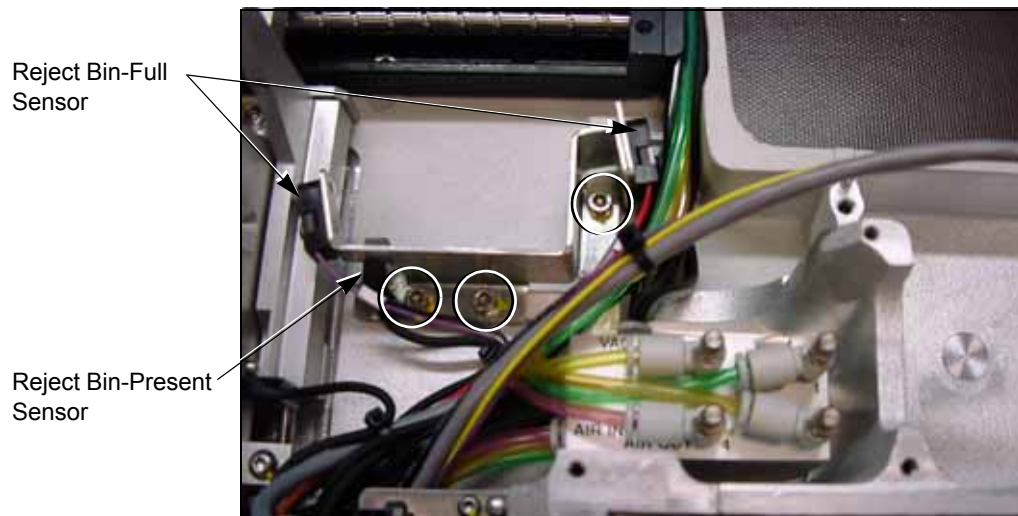

Figure P-26—Reject Bin Sensors and Bracket Screw Locations.

10. Unscrew one screw through each sensor to remove the sensor.

NOTE: The Reject Bin-Full Sensor consists of two sensors. They should be replaced as a set.

To install the Reject Bin-Full Sensor, reverse the removal procedures:

- Reinstall the Sensors, and the Reject Bin Bracket
- Reinstall the Conveyor Module. Set the Conveyor height as described in “Reinstalling the Conveyor Module.”
- Reinstall the Lower Cover.

Control Panel Module

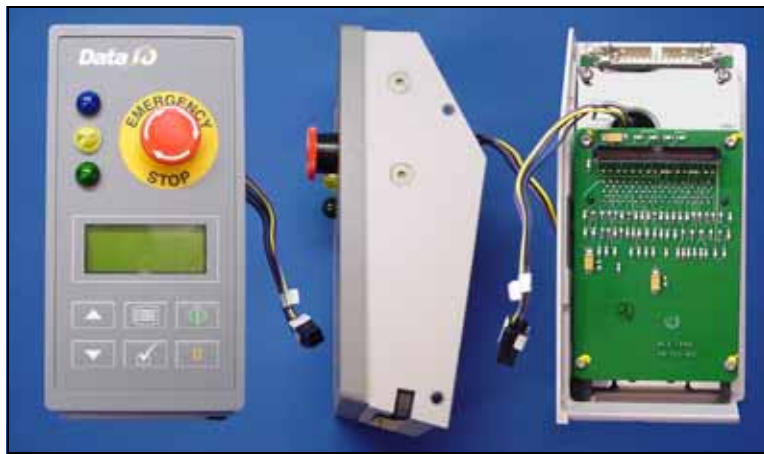

Figure P-27—Control Panel Module

The Control Panel Module consists of the PCMCIA Card Drive, the Stop button, the Indicator Lights, Control Panel buttons and LCD screen. If any of the components in the Control Panel Module are not functioning correctly, check the wiring connections and the condition of the PCMCIA card.

Test the PCMCIA Card Drive with a card that is known to function. If components are still not functioning after connections are tested, return the Control Panel Module to Data I/O for repair.

NOTE: Do not disassemble the Control Panel Module. If a component is not functioning, send the entire Control Panel Module back to Data I/O.

Data I/O Parts Ordering Information

Instructions: 1. Copy this page. 2. Fill in your RoadRunner model and serial numbers (see the label on the chassis under the Robotics Cover). 3. Fill in the quantity for the item(s) desired. 4. Call Data I/O, or visit our Web site, for part prices (optional). 5. Mail or FAX it with your purchase order to Data I/O. See the last page of this manual for contact information.

ProLINE-RoadRunner Model No. _____ Serial No. _____

Model Name	Part Description	Qty	Price Ea.	Totals
RR-CONTROL PANEL M	Control Panel Module		\$	\$
			\$	\$
			\$	\$
			\$	\$

Signature: _____ Date: _____ Company: _____

Removing the Control Panel Module



For more information, see “Removing the Robotics Cover” on page P-5.

1. Pause the RoadRunner.
2. Remove the PCMCIA card when the blue light is on.
3. Turn the power off.
4. Disconnect the RoadRunner power cord and air supply.
5. Remove the Robotics Cover.
6. Remove the PCMCIA Ribbon Cable Guard by unscrewing the two screws securing it.

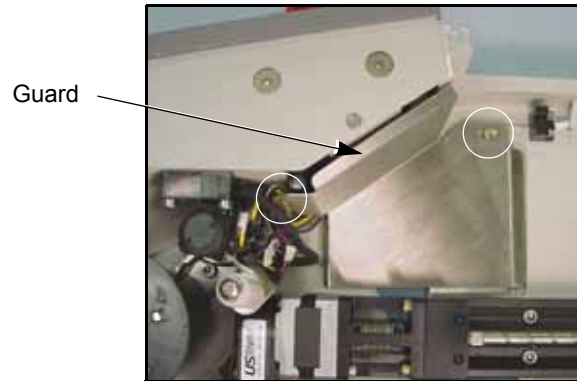

Figure P-28—Ribbon Cable Guard with Screw Locations Indicated

7. Unplug the PCMCIA Card Drive ribbon cable, the Control Panel Ribbon Cable, and the wires for the Emergency Stop button.

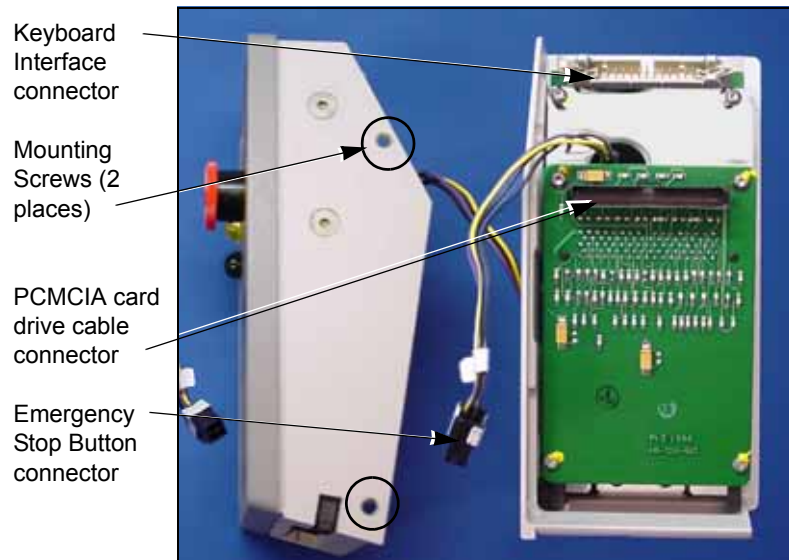

Figure P-29—Location of Connectors and Screws on the Control Panel.

8. Remove the screws securing the Control Panel Module to the RoadRunner chassis.

9. Remove the Control Panel Module.

Replacement is the in the reverse order of removal.

When reassembled, verify the proper operation of the the following:

- Card Reader and indicator lamps
- Display
- Keypad
- Emergency Stop

Pick and Place Head

The head assembly contains four probes, each with Vacuum Tips and Vacuum Chamber Blocks. Some parts can be replaced and some probe functions can be adjusted.

Aligning the PNP Head

Since device placement tolerance is small, the PNP head may need aligning when a module is replaced or repaired. The head may also need aligning if any of the following error messages are displayed:

- Device pick failure at input, with probe *n*.
- Device pick failure on probe *n*.
- Device dropped from head *n*.

For head alignment procedures see “Setting the *Tape* Parameter” and “Setting the *Skt 1* Parameter” in Operation Chapter of the Owner's Manual.

Adjusting and Balancing Probe Speed

If the probe speed is too fast, devices in the carrier tape become unsettled as a probe strikes a device during the pick routine. If the probe speed is too slow, throughput will suffer and device placement problems may occur.

Adjust the probe speed with power and pressurized air on. Ensure that vacuum to all probes is disabled before starting this procedure. The easiest way to ensure this is to cycle the power.



See “*Loading Device Tape*” on page 3-10 and “*Aligning the Device Tape*” on page 3-12.

1. Load and align the device tape without peeling off the cover tape. (The Cover Tape Peel Bar and Spool will not be used.)

WARNING

Pinch point: Moving mechanical parts. Keep hands away from moving parts. The following procedures require the Robotics Cover to be removed while mechanical parts are in motion. Use caution.

2. Scroll to and select *Robot Diagnostics*.
3. Scroll to and select *Probe 1*.
4. Scroll to and select *Speed*. The probe will move to the device pick point and cycle continuously.
5. Read the speed that is now displayed in the screen.
The speed should be 135 ± 5 .
If it needs adjustment skip to step 6.
If it does not need adjustment:
 - 5a. Press *Menu*.

- 5b. Scroll to and select the next probe.
- 5c. Repeat steps 4 and on.
6. Remove the Conveyor Module Cover.
7. Loosen the locknut ring on the Probe Speed Flow Control for Probe 1 (or current probe) on the Interface Manifold.

The Interface Manifold is mounted on the chassis below, and to the right of, the Reject Bin.

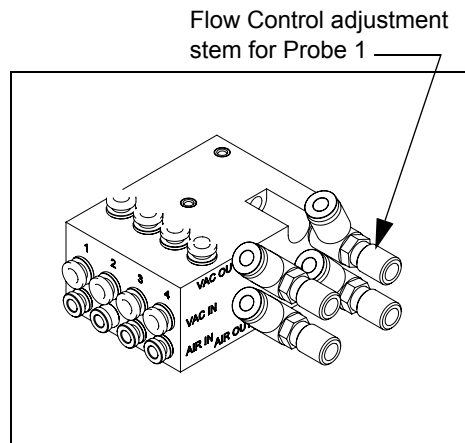

*Figure P-30—Interface Manifold
(Adjustment stems may have thumbscrews or slots for screwdriver.)*

8. Adjust the Probe Speed flow control for Probe 1 (or current probe) while watching the speed displayed at the keypad screen.
9. When the speed is within the proper range, press *Menu*—probe motion will stop.
10. Tighten the locknut ring on the Flow Control.
11. Recheck the speed. If it is outside the proper range then readjust.
12. Scroll to and select the next Probe.
13. Repeat steps 4 and on for the next probe.

Resetting the *Pick* Delay and *Travel* Delay Times

The delay times do not change and do not usually require adjustment. The factory-set values are indicated in the following flow charts.

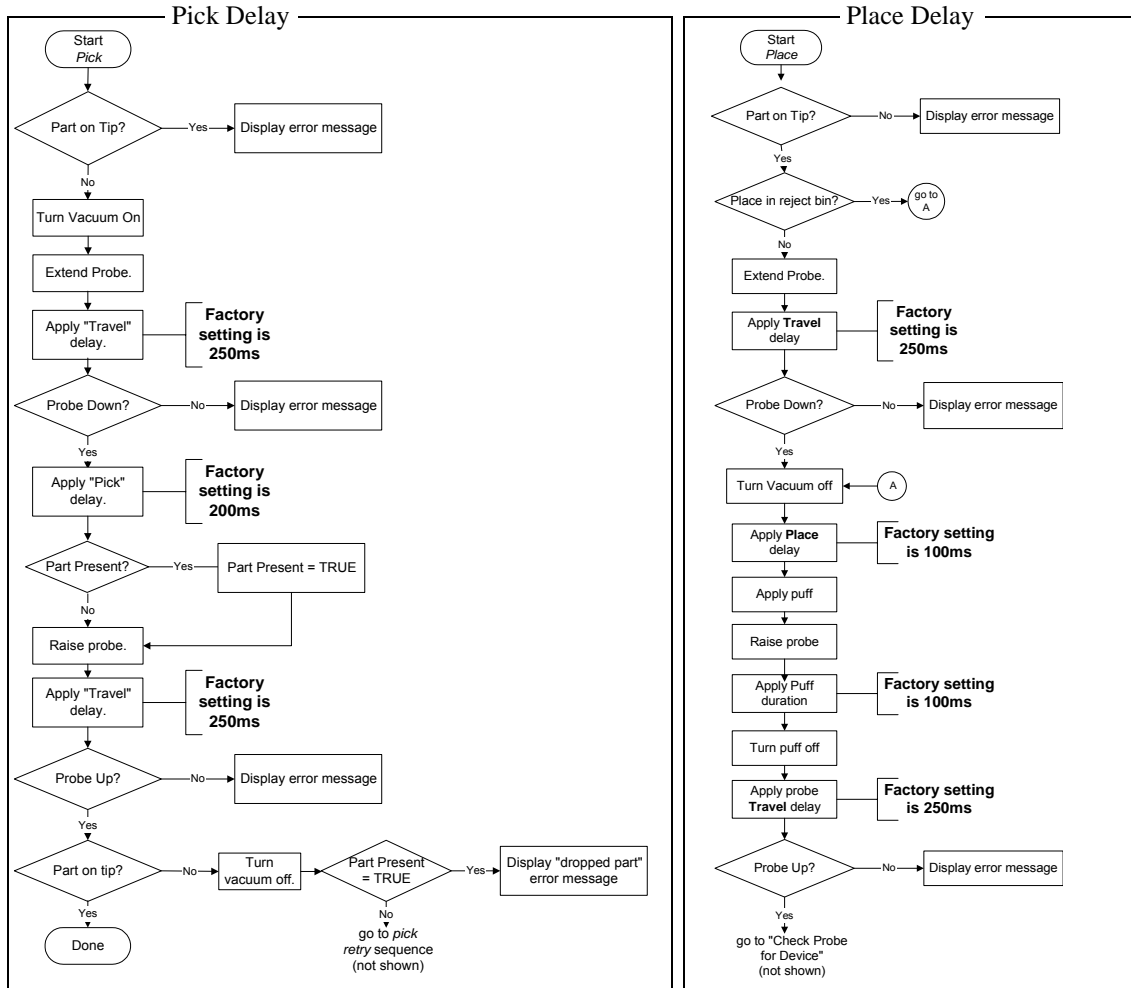

Figure P-31—Pick and Place Delay Flow Charts

These values only affect the internal verification delay time, as indicated in the flow charts.

To reset delay times:

1. From the top level menu on the display, select *Operation*.
2. Scroll to and select *Probes*.
3. Scroll to and select the setting you wish to adjust.
4. Use the *Arrow Up* and *Arrow Down* buttons to change the setting.
5. When finished, select *Menu*.

Adjusting Probe Vacuum Sensors



See “Loading Device Tape” on page 3-10.

See “Aligning the Device Tape” on page 3-12

1. Load *empty* device tape into RoadRunner.
2. Advance the tape until the hole in the center of a tape pocket is aligned within one scroll-button-increment of the scribe mark on the input tape module.
3. Push the Emergency Stop button.
4. Pushing the head with your hand, center the probe on the hole in the center of the device tape pocket.
5. Select *Menu* until you reach the top menu level and select *Robot Diagnostics*.
 - 5a. Scroll to and select *Probe 1*.
 - 5b. Scroll to and select *Vacuum*.
 - 5c. Press the *Up Arrow* to enable the probe.
6. Remove the Lower Cover.
7. Press Probe 1 down by hand until it contacts the tape pocket and hold it.
 - 7a. Turn the vacuum sensor adjust screw for Probe 1 (the first adjustment block) counter-clockwise until the red LED adjacent to the adjustment screw illuminates.

If the vacuum for Probe 1 is enabled, the two small LEDs on the solenoids for Probe 1 will be unlit.

Adjustment LED for Probe #1 (typical)

Vacuum Sensor Adjustment Screw for Probe #1 (typical)

Solenoid switches for Probe #1 (typical)

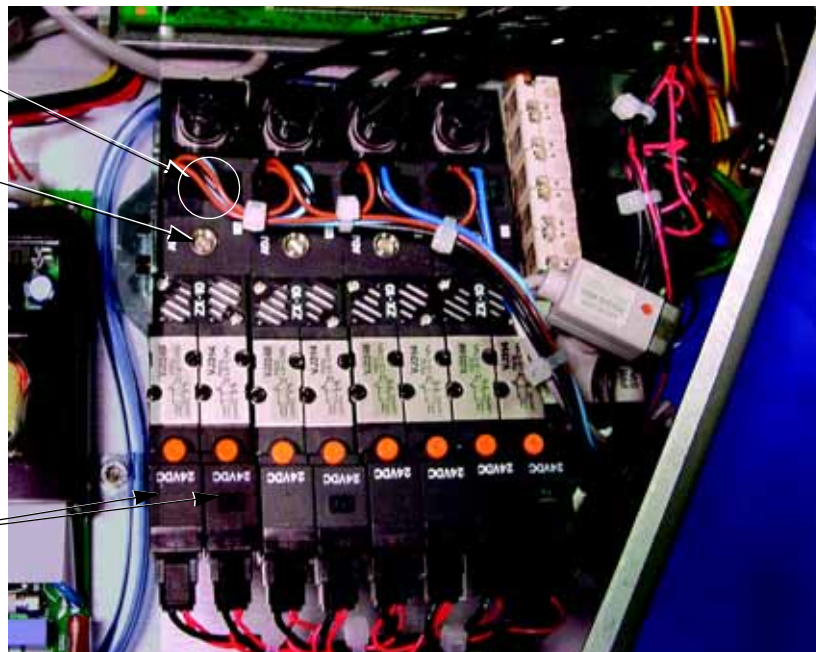

Figure P-32—Pneumatic Valve Block

- 7b. Turn the vacuum sensor adjust screw for Probe 1 clockwise until the red LED goes out. Continue turning the screw 1 revolution clockwise. Release the probe allowing it to resume the up position.
8. Select *Menu* until you reach the top menu level again and select *Robot Diagnostics*.
 - 8a. Scroll to and select *Probe 1*.
 - 8b. Scroll to and select *Vacuum*.
 - 8c. Press the *Down Arrow* to disable the probe.
9. Manually position probes 2, 3 and 4 over the hole in the tape pocket and repeat steps 5 through 7 for each.
10. Re-install the Lower Cover when finished.

Removing the PNP Head

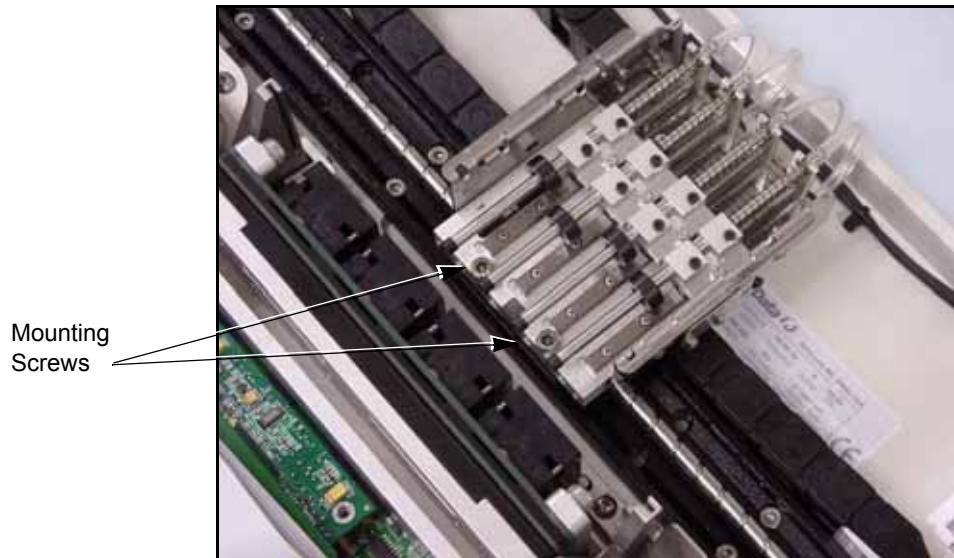

Figure P-33—Removing the PNP Head

If you receive error messages relating to the Pick and Place function, refer to the troubleshooting chart in chapter 9.

If you experience trouble with the Pick and Place Head that is not covered in this manual, remove the head and send it to Data I/O Customer Service for repair or replacement.

Removal procedures are on the following page.

Data I/O Parts Ordering Information

Instructions: 1. Copy this page. 2. Fill in your RoadRunner model and serial numbers (see the label on the chassis under the Robotics Cover). 3. Fill in the quantity for the item(s) desired. 4. Call Data I/O, or visit our Web site, for part prices (optional). 5. Mail or FAX it with your purchase order to Data I/O. See the last page of this manual for contact information.

ProLINE-RoadRunner Model No. _____ Serial No. _____

Model Name	Part Description	Qty	Price Ea.	Totals
PNP HEAD	Pick and Place Head		\$	\$
RR-VAC TIP	Probe Tip		\$	\$
BRACKET PNP	PNP Head Bracket		\$	\$
RR-CHAMBER FLOATING BLOCK	Vacuum Chamber Block		\$	\$

Signature: _____ Date: _____ Company: _____



For screw locations see
Figure P-33 on page P-38.

To remove the Pick and Place Head:

1. Turn the power off.
2. Disconnect the RoadRunner power cord and air supply.
3. Remove the Robotics Cover.
4. Remove the PNP Head Cover.
5. Disconnect the tube from the top of each probe.
6. Remove two socket head cap screws attaching the head to the ball screw carriage.
7. Lightly pull the head a couple of centimeters away from the carriage.
8. Remove four pneumatic tubes with fittings from the back of the head with a straight screwdriver. Note that each has a washer.



Figure P-34—The PNP Head Partially Removed



Tube Fitting and Gasket.

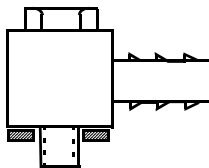

For more information, see
the “*Linear Stage Installation Verification*” on page
P-48.

9. Remove two Head Bracket screws from each side of the head.

To reinstall a PNP Head, reverse the steps for removal *and* perform the following:

1. Install the four fittings onto the new head—the tubes are still attached. Ensure that each has a gasket.
2. Install the head Bracket onto the head.
3. Plug in the electric connector and tie wrap to the tie wrap block.
4. Attach the tubes to the probes.
5. Install the head to the Linear stage with the two socket screws. Use Loctite.
6. Perform the “Linear Stage Reinstallation Verification” procedure.

Programmer Module

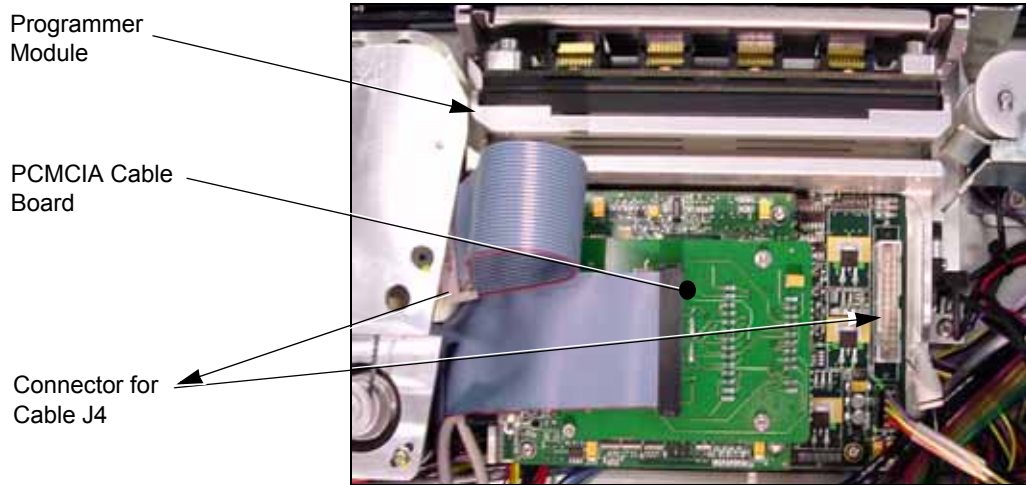

Figure P-35—Programmer Module. Cable J4 has been Unplugged.

The Programmer Module consists of the WaveForm Board, Main Controller Board, BackPlane Board, the Socket Adapter, and the Socket Actuator that opens and closes the programmer sockets.

If Programmer Module sockets become worn, the Socket Adapter needs attention. The Socket Adapter needs cleaning when yield drops, and needs replacing when cleaning fails to boost yield.

If replacing the Socket Adapter does not solve problems in the Programmer Module, see “Diagnosing with the Adapter Board” in Chapter 5 of the Owner’s Manual, or contact Data I/O for Programmer Module replacement or repair. Programmer Module removal directions start on page P-41.

4P



For more information, see “Changing the Socket Adapter” in Chapter 3 of the Owner’s Manual.

Data I/O Parts Ordering Information

Instructions: 1. Copy this page. 2. Fill in your RoadRunner model and serial numbers (see the label on the chassis under the Robotics Cover). 3. Fill in the quantity for the item(s) desired. 4. Call Data I/O, or visit our Web site, for part prices (optional). 5. Mail or FAX it with your purchase order to Data I/O. See the last page of this manual for contact information.

ProLINE-RoadRunner Model No. _____ Serial No. _____

Model Name	Part Description	Qty	Price Ea.	Totals
RR-PROGRAMMER MOD	Programmer Module		\$	\$
PROGRAMMER ALIGNMENT TOOL	Programmer Alignment Tool		\$	\$
ASSY,PROGRAMMER W/GUIDE.RR-uC	Programmer Module, Microcontroller		\$	\$
			\$	\$

Signature: _____ Date: _____ Company: _____

P

Removing the Programmer Module

NOTE: Only technicians who have taken the ProLINE-RoadRunner Service training course should attempt to remove the Programmer Module.

A special alignment tool is required from Data I/O to reinstall the Programmer Module.

1. Switch the power off.
2. Disconnect the RoadRunner power cord and air supply.
3. Lift off the Robotics Cover.
4. Push the head away from the programmer.
5. Remove the Lower Cover.
6. Remove the Actuator Plate by sliding it out of the bracket.
7. Optional: Remove the Socket Adapter.
8. Remove the Conveyor Module Cover.
9. Lift out the Reject Bin.
10. Remove screws from the Conveyor Module and set it aside—wires are still attached.
11. Remove the Reject Bin Bracket. Sensors do not need to be removed. Wires do not need to be unplugged. Move it out of the way.



See “Changing the Socket Adapter” on page 3-5.

See “Removing the Conveyor Module” on page P-24

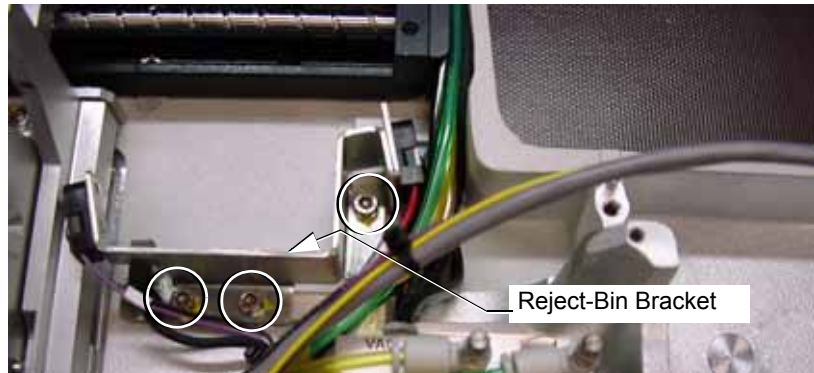

Figure P-36—Reject Bin Bracket Screw Locations

CAUTION: Ribbon Cables might get damaged if pulled or pinched. Cable damage is often not visible. Pull cables by the connector only.



Cables are identified in Figure P-37 below.

12. Unplug the Ribbon Cable J4 from the Programmer Module.

13. Unplug the Cable J3 from the Programmer Module.
14. Remove the PCMCIA Cable PCB by removing four socket-head cap screws and lifting up on the PCB. Set it aside—the cable is still attached.
15. Unplug the Motion Controller Cable (709-0560) from the left side of the Programmer Module.
16. If equipped, unplug the Ethernet Cable (701-3215) from the left side of the Programmer Module, adjacent to the Motion Controller Cable.

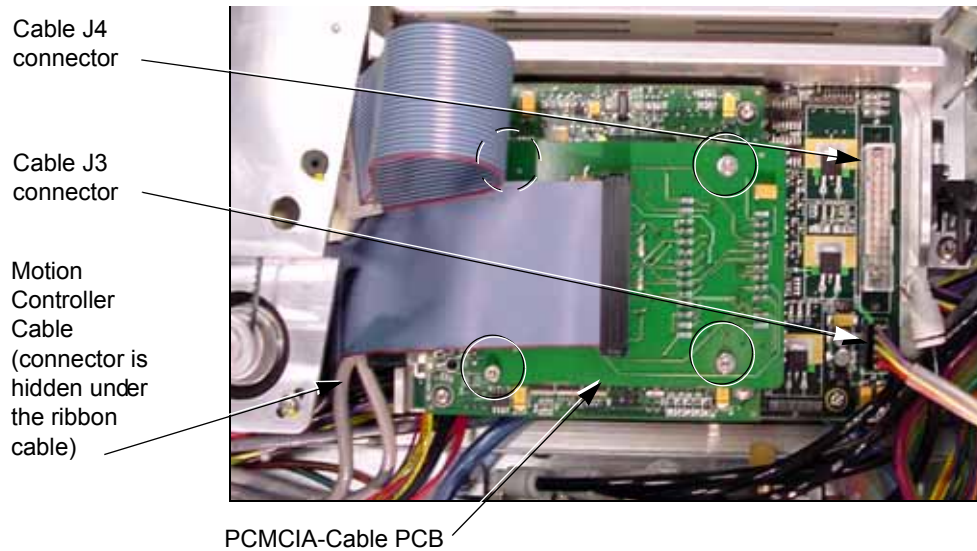

Figure P-37— Cable Connectors and PCMCIA-Cable PCB Fasteners (circles)

17. Disconnect the air tube from the Programmer Module. It is a one-touch fitting.
18. Disconnect the Programmer Module's Actuator Position Sensor Cable, J5C, from the Cable Interconnect Panel. Cut the cable ties.



See Cable J5C in Figure P-38 below.

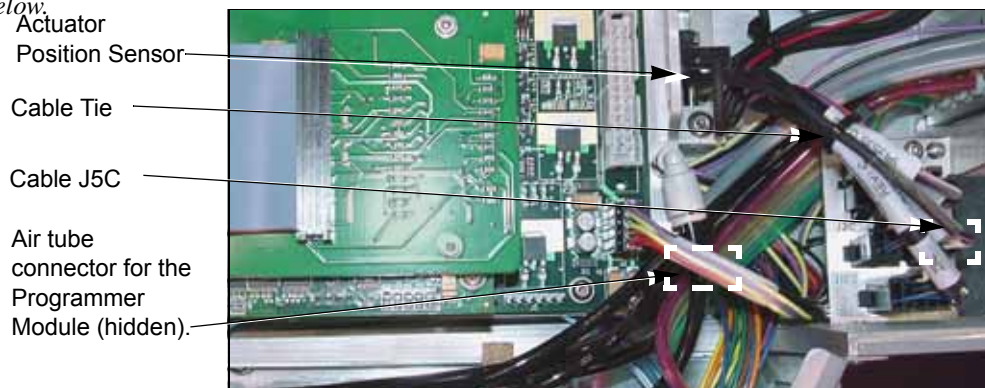

Figure P-38—Cable Interconnect Panel

4P

P

19. Remove four button head socket screws attaching the Programmer Module to the chassis.



Figure P-39—Location of Programmer Screws

20. Lift the Programmer Module out from the chassis.

NOTE: If you see shims under the Programmer Module it is an old model. Discard the shims when installing a new Module.

Reinstalling the Programmer Module

To reinstall a Programmer Module perform the following steps:

1. Reinstall a Programmer Module ensuring that no wires or hoses are pinched, and tighten the four screws.
2. Reinstall the air tube.
3. Reinstall all cable connectors.
4. Plug in the PCMCIA Cable PCB and install the four screws.

Align the Programmer Module as described below before completing reinstallation.

Aligning the Programmer Module

Align the Programmer Module as follows:



Figure P-40—The Programmer Module Alignment Tool Installed on the Programmer

CAUTION: *Chassis might get damaged. Loosen the Programmer Module mounting screws (two upper screws) before each attempt to adjust the Programmer Alignment Screws.*

1. Install the Programmer Alignment Tool (model name PROGRAMMER ALIGNMENT TOOL) onto the Programmer Module in place of a socket adapter.
2. Loosen the upper two Programmer Module mounting screws two revolutions.
3. Remove the rubber tip from Probe 1 and extend Probe 1 into the alignment fixture hole for socket #1. If the probe **passes** through the hole easily, then the left side of the programmer is properly aligned—skip to step 4.
 - 3a. If Probe 1 **does not pass** through easily, adjust the left Position Adjustment set screw so that the probe does pass through easily. Turn the screw clockwise to move the module away from the chassis.

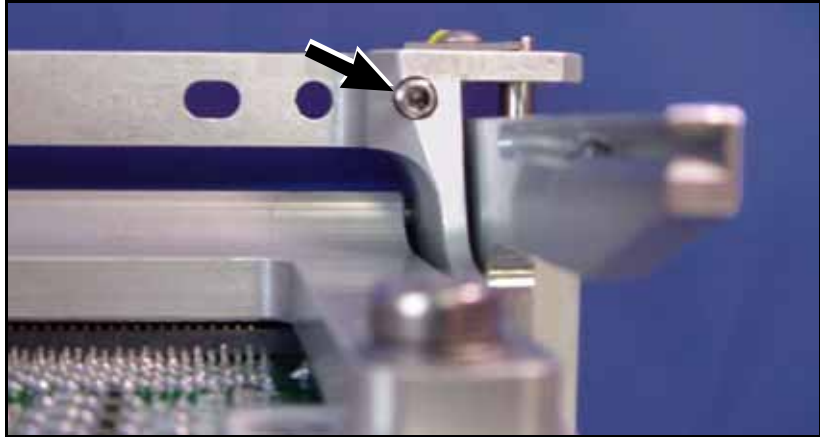

Figure P-41—Programmer Module Alignment Screws (the Left Hand Screw is not shown)

4. Without the rubber tip on, extend Probe 4 into the alignment fixture hole for socket #4. If the probe **passes** through the hole easily, then the right side of the programmer is properly aligned—skip to step 5.
 - 4a. If probe 4 **does not pass** through easily, adjust the right Position Adjustment set screw accordingly.
5. Tighten the upper two Programmer Module screws and **retest**. If the module requires further adjustment, be sure to loosen the upper two mounting screws first.
6. Remove the Alignment Tool.

Complete the Programmer Module installation by installing the Reject Bin Bracket, the Conveyor Module, the Reject Bin, and the Lower Cover.

Linear Stage Module

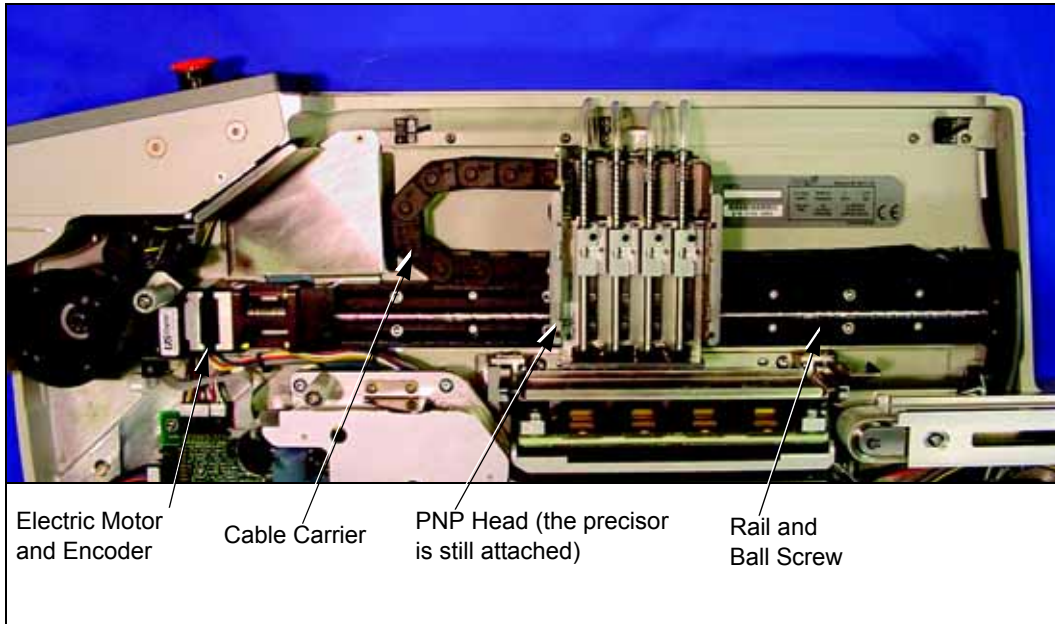

Figure P-42—The Linear Stage Module

4P



To remove the PNP Head only, see “Removing the PNP Head” on page P-38.

The Linear Stage, part of the Robotic System, consists of a rail and ball screw, a stepper motor with encoder, and a cable carrier. The Linear Stage is removed as a module with the PNP Head.

Data I/O Parts Ordering Information

Instructions: 1. Copy this page. 2. Fill in your RoadRunner model and serial numbers (see the label on the chassis under the Robotics Cover). 3. Fill in the quantity for the item(s) desired. 4. Call Data I/O, or visit our Web site, for part prices (optional). 5. Mail or FAX it with your purchase order to Data I/O. See the last page of this manual for contact information.

ProLINE-RoadRunner Model No. _____ Serial No. _____

Model Name	Part Description	Qty	Price Ea.	Totals
RR-LINEAR MODULE	Linear Stage Module		\$	\$
			\$	\$
			\$	\$

Signature: _____ Date: _____ Company: _____

P

Removing the Linear Stage Module



See “Removing the Lower Cover” on page P-5.



See “Removing the Conveyor Module” on page P-24.

1. Switch the power off.
2. Disconnect the RoadRunner power cord and air supply.
3. Lift off the Robotics Cover.
4. Pull off the PNP Head Cover. It is magnetically attached to the head.
5. Remove the Lower Cover.
6. Remove the Conveyor Module Cover.
7. Remove the Conveyor Module screws (the wires do not need to be unplugged) and lift it out of the way.
8. Lift out the Reject Bin.
9. (Label if necessary and) disconnect four *black* Linear Stage air hoses from the Interface Manifold’s upper surface. The Interface Manifold is located below the Reject Bin Bracket.
10. (Label if necessary and) disconnect four *colored* air hoses from the Interface Manifold.
11. Unplug electrical connector J8B from the extension cable connector. It goes to the linear stage motor. The cable is tucked beneath the Tape-In Module and pulls out far enough for connector access. See figure below.

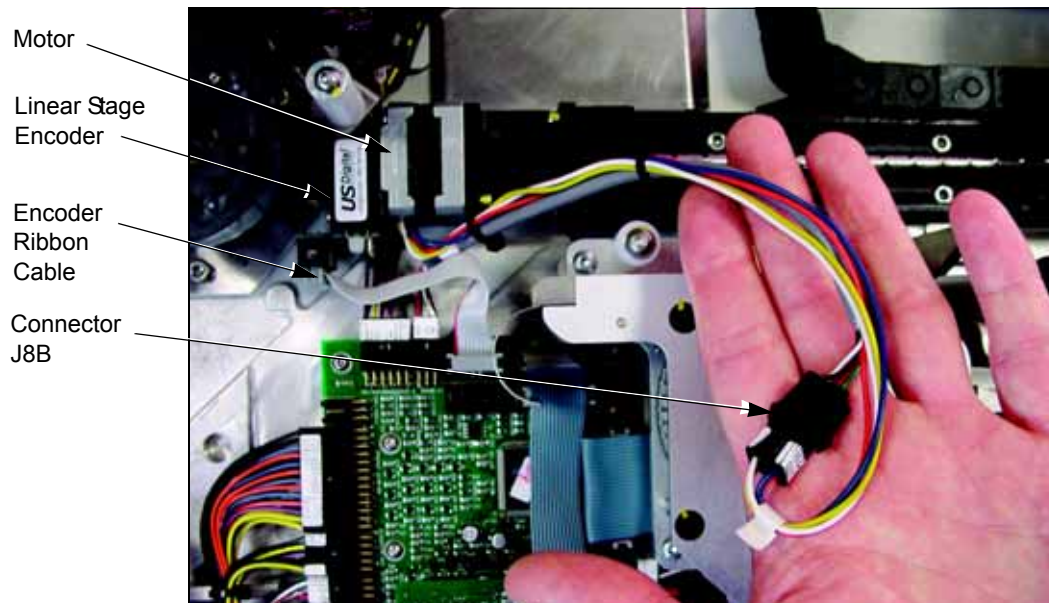

Figure P-43—Wires from the Linear Stage Motor terminate at intermediate connector J8B beneath the Tape-In Module

12. Unplug the ribbon cable at the Linear Stage Encoder.
13. Remove eight screws securing the linear stage to the chassis. (Slide the head out of the way.) See the figure below.



Figure P-44—Linear Stage Screw Locations. (Two are hidden by the head.)

Linear Stage Installation Verification

To replace the Linear Stage Module, reverse the steps for removal *and* perform the following:

1. With the power off, cycle the PNP Head along the entire length of the Linear Stage. Check that the Head Flag clears all three position sensors.
2. Verify electrical and pneumatic connections as follows:
 - 2a. Connect the air hose and turn the power on.
 - 2b. Verify that the head homes.
 - 2c. Verify that the *Position* field at the keypad display toggles when each probe is lowered by hand. *Robot Diagnostics » Probe X » Position*.
 - 2d. Extend and retract each probe to verify correct plumbing. *Robot Diagnostics » Probe X » Position » Arrow Up/Down*.
 - 2e. Enable vacuum to each probe to verify correct plumbing. *Robot Diagnostics » Probe X » Vac Sense » Arrow Up/Down*.
3. Adjust the Probe Vacuum Sensors.
4. Verify correct Probe Speed.
5. Perform the “Aligning the Programmer Module” procedure.
6. Reteach the robot the four operation parameters: Tape, Socket1, Reject and Belt.



For probe vacuum settings see “Adjusting Probe Vacuum Sensors” on page P-36.

For probe speed information see “Adjusting and Balancing Probe Speed” on page P-33.

For Programmer alignment see “Aligning the Programmer Module” on page P-44.

For reteaching the robot see “Setting Operational Parameters” on page 3-19.

Blank page.

4P

P

Basic Spares Kit, Memory RoadRunner

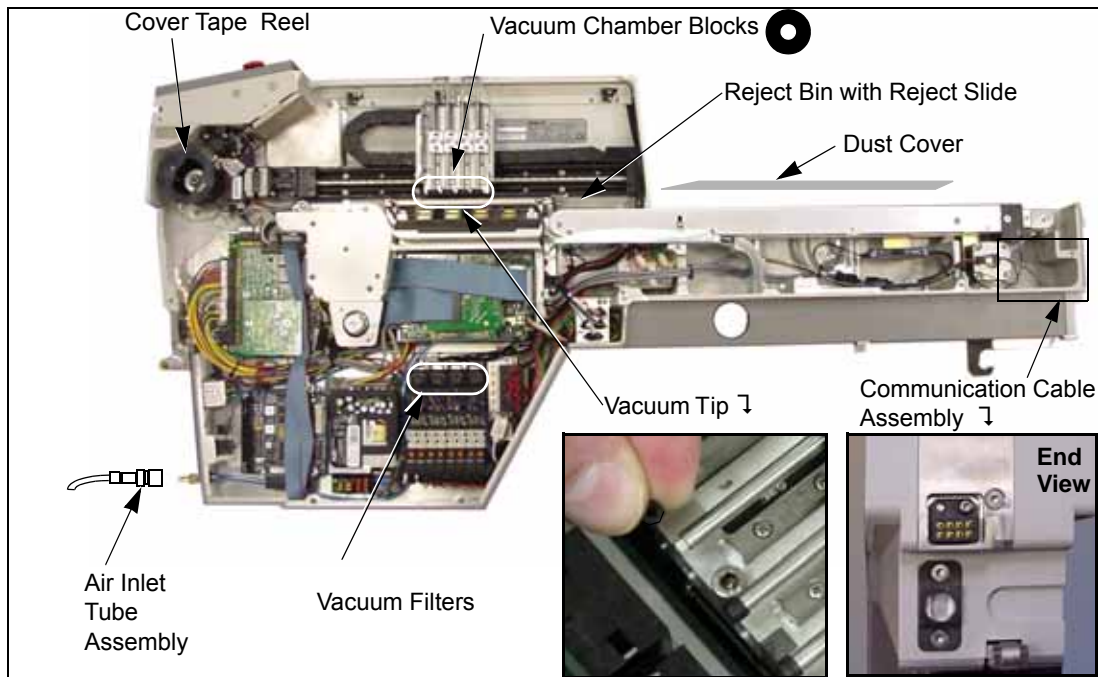

Figure P-45—Parts in the Basic Spares Kit; Memory RoadRunner

Two spare parts kits are available for the Memory RoadRunner. Parts in the Basic Spares Kit are listed below. For the larger kit, “Self-Service Spares Kit,” see [page P-52](#).

Data I/O Parts Ordering Information

Instructions: 1. Copy this page. 2. Fill in your RoadRunner model and serial numbers (see the label on the chassis under the Robotics Cover). 3. Fill in the quantity for the item(s) desired. 4. Call Data I/O, or visit our Web site, for part prices (optional). 5. Mail or FAX it with your purchase order to Data I/O. See the last page of this manual for contact information.

ProLINE-RoadRunner Model No. _____ Serial No. _____

Model Name	Part Description	Qty	Price Ea.	Totals
RR-VAC TIP	Probe Tip		\$	\$
RR-VAC FILTER	Vacuum Filter		\$	\$
RR-COVER DUST-S	Conveyor Dust Cover		\$	\$
RR-ASSY AIR TUBE	Air Inlet Tube Assembly		\$	\$
RR-REJECT BIN	Reject Bin		\$	\$
RR-SLEEVE TAKE UP WHEEL SLTD	Cover Tape Take-Up Reel, Slotted		\$	\$
RR-SLEEVE TAKE UP WHEEL 6 HL	Cover Tape Take-Up Reel, 6 Holes		\$	\$
RR-CHAMBER FLOATING BLOCK	Vacuum Chamber Block		\$	\$
CABLE ASSY, COMM, PANA	Feeder Communications Cable Assy		\$	\$
RR-FILTER AIR 1/4-3/8	Filter, Air, 1/4 - 3/8		\$	\$
RR-FILTER MIST SEP 1/4-3/8	Filter, Mist		\$	\$
RR-BASIC SPARES KIT - P	Basic Spares Kit (all the above)		\$	\$

Signature: _____ Date: _____ Company: _____

Replacing the Probe Tips

The rubber tip pulls straight off. Hold a new tip with the square hole oriented to the square end of the probe and work it onto the probe on.

Replacing the Air Inlet Tube Assembly

To remove the Air Inlet Tube Assembly at the RoadRunner air connector:

1. Stop or pause the job if one is running.
2. If there are any devices currently on the probes, remove them; they will fall off when air is removed.
3. Pull the collar on the quick release fitting back as you pull the tube assembly off the connector. (The quick release fitting has a safety shut off feature—the compressed air need not be turned off.)

To connect an Air Inlet Tube Assembly, push it onto the RoadRunner connector.

Self-Service Spares Kit, Memory RoadRunner

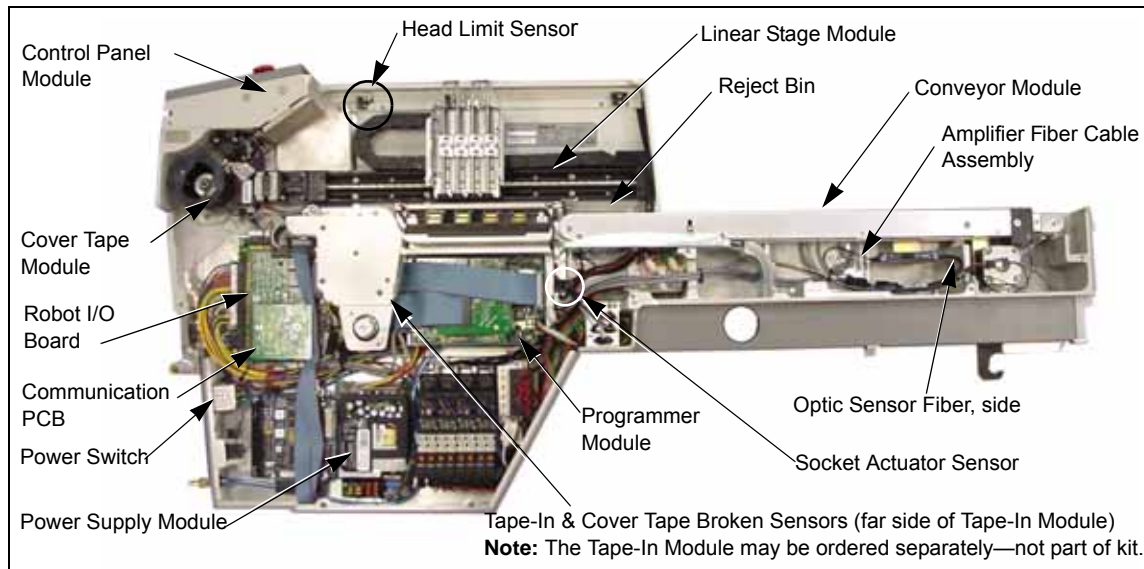

Figure P-46—Parts in the Self-Service Spares Kit; Memory RoadRunner

4P

Data I/O Parts Ordering Information

Instructions: 1. Copy this page. 2. Fill in your RoadRunner model and serial numbers (see the label on the chassis under the Robotics Cover). 3. Fill in the quantity for the item(s) desired. 4. Call Data I/O, or visit our Web site, for part prices (optional). 5. Mail or FAX it with your purchase order to Data I/O. See the last page of this manual for contact information.

ProLINE-RoadRunner Model No. _____ Serial No. _____

Model Name	Part Description	Qty	Price Ea.	Totals
RR-PWR SWITCH	Power Switch, Rocker		\$	\$
RR-PWR SUPPLY	Power Supply Module		\$	\$
RR-REJECT BIN SENS	Reject Bin Sensor (Cable Assy)		\$	\$
RR-LIMIT SENSOR CA	Head Limit Sensor (Cable Assy)		\$	\$
RR-SLOT SENSOR CAB	Slot Sensor Cable Assembly (Tape)		\$	\$
RR- OPTIC SENSOR	Optical Sensor Fiber, side		\$	\$
RR-LINEAR MODULE	Linear Stage Module		\$	\$
RR-ASSY CONV, PANA	Conveyor Module		\$	\$
RR-PROGRAMMER MOD	Programmer Module		\$	\$
RR-CTRL PNL MODULE	Control Panel Module		\$	\$
RR-PCMCIA CABLE	Control Panel Cable		\$	\$
RR-COVER TAPE MOD	Cover Tape Module		\$	\$
RR-ROBOT I/O COMM	Robot I/O Board Module		\$	\$
RR-FIBER OPTIC CA	Amplifier Fiber Cable Assembly		\$	\$
RR-SMT COMM PORT	Communications PCB		\$	\$
RR-PNEUMATIC MODULE	Pneumatic Module		\$	\$
RR-DIAGNOSTICS BOARD	Diagnostics Adapter Board (DAB)		\$	\$
PROGRAMMER ALIGNMENT TOOL	Programmer Alignment Tool		\$	\$

Signature: _____ Date: _____ Company: _____

P

The Self-Service Spares Kit for Memory RoadRunner (RR-SELFSV SPARES KIT-P) contains parts listed on page P-52. It is available to those who have attended an Advanced RoadRunner Service course.

Customer Training

For information about advanced training, contact the Data I/O Customer Service Center. A training course may be ordered when purchasing a RoadRunner or at a later time.

NOTE: This manual does not list replacement instructions for all the parts in the Self-Service Spares Kit. For additional information, contact Data I/O or your nearest authorized representative. To find your nearest representative, see the instructions on the last page of this manual.

Basic Spares Kit, Microcontroller RoadRunner

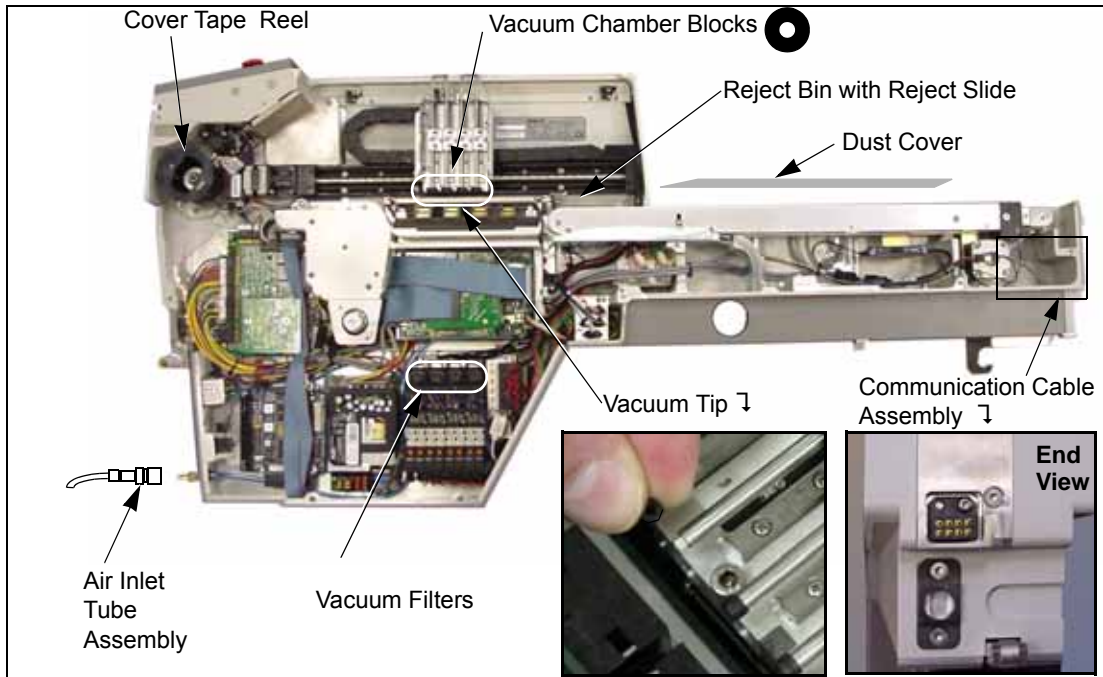

Figure P-47—Parts in the Basic Spares Kit; Microcontroller RoadRunner

Two spare parts kits are available for the Microcontroller RoadRunner. Parts in the Basic Spares Kit are listed below. For the larger kit, “Self-Service Spares Kit,” see [page P-56](#).

Data I/O Parts Ordering Information

Instructions: 1. Copy this page. 2. Fill in your RoadRunner model and serial numbers (see the label on the chassis under the Robotics Cover). 3. Fill in the quantity for the item(s) desired. 4. Call Data I/O, or visit our Web site, for part prices (optional). 5. Mail or FAX it with your purchase order to Data I/O. See the last page of this manual for contact information.

ProLINE-RoadRunner Model No. _____ Serial No. _____

Model Name	Part Description	Qty	Price Ea.	Totals
RR-VAC TIP	Probe Tip		\$	\$
RR-VAC FILTER	Vacuum Filter		\$	\$
RR-COVER DUST-S	Conveyor Dust Cover		\$	\$
RR-ASSY AIR TUBE	Air Inlet Tube Assembly		\$	\$
ASSY,REJECT BIN,RR-uC	Reject Bin, Microcontroller		\$	\$
RR-SLEEVE TAKE UP WHEEL SLTD	Cover Tape Take-Up Reel, Slotted		\$	\$
RR-SLEEVE TAKE UP WHEEL 6 HL	Cover Tape Take-Up Reel, 6 Holes		\$	\$
RR-CHAMBER FLOATING BLOCK	Vacuum Chamber Block		\$	\$
CABLE ASSY, COMM, PANA	Feeder Communications Cable Assy		\$	\$
RR-FILTER AIR 1/4-3/8	Filter, Air, 1/4 - 3/8		\$	\$
RR-FILTER MIST SEP 1/4-3/8	Filter, Mist		\$	\$
RR-MICRO-BASIC SPARES KIT-P	Basic Spares Kit -uC (all the above)		\$	\$

Signature: _____ Date: _____ Company: _____

Replacing the Probe Tips

The rubber tip pulls straight off. Hold a new tip with the square hole oriented to the square end of the probe and work it onto the probe on.

Replacing the Air Inlet Tube Assembly

To remove the Air Inlet Tube Assembly at the RoadRunner air connector:

1. Stop or pause the job if one is running.
2. If there are any devices currently on the probes, remove them; they will fall off when air is removed.
3. Pull the collar on the quick release fitting back as you pull the tube assembly off the connector. (The quick release fitting has a safety shut off feature—the compressed air need not be turned off.)

To connect an Air Inlet Tube Assembly, push it onto the RoadRunner connector.

Self-Service Spares Kit, Microcontroller RoadRunner

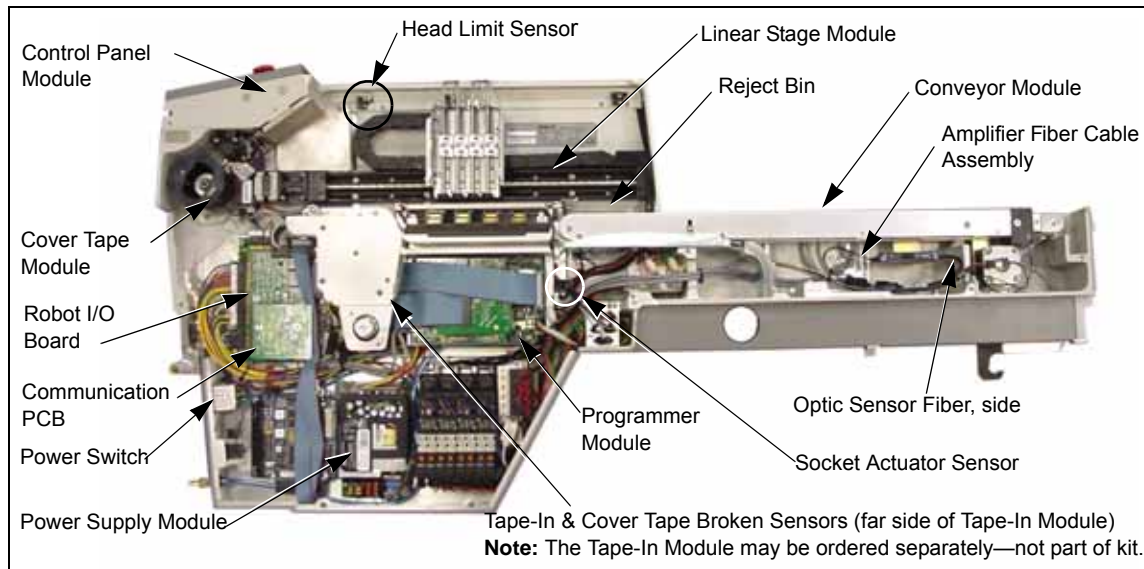

Figure P-48—Self-Service Spares Kit; Microcontroller RoadRunner

4P

Data I/O Parts Ordering Information

Instructions: 1. Copy this page. 2. Fill in your RoadRunner model and serial numbers (see the label on the chassis under the Robotics Cover). 3. Fill in the quantity for the item(s) desired. 4. Call Data I/O, or visit our Web site, for part prices (optional). 5. Mail or FAX it with your purchase order to Data I/O. See the last page of this manual for contact information.

ProLINE-RoadRunner Model No. _____ Serial No. _____

Model Name	Part Description	Qty	Price Ea.	Totals
RR-PWR SWITCH	Power Switch, Rocker		\$	\$
RR-PWR SUPPLY	Power Supply Module		\$	\$
RR-REJECT BIN SENS	Reject Bin Sensor (Cable Assy)		\$	\$
RR-LIMIT SENSOR CA	Head Limit Sensor (Cable Assy)		\$	\$
RR-SLOT SENSOR CAB	Slot Sensor Cable Assembly (Tape)		\$	\$
RR- OPTIC SENSOR	Optical Sensor Fiber, side		\$	\$
RR-LINEAR MODULE	Linear Stage Module		\$	\$
ASSY,CONVEYOR 16MM,PANA-SONIC,RR0uC	Conveyor Module, Microcontroller		\$	\$
ASSY,PROGRAMMER W/GUIDE,RR-uC	Programmer Module, µcontroller		\$	\$
RR-CTRL PNL MODULE	Control Panel Module		\$	\$
RR-PCMCIA CABLE	Control Panel Cable		\$	\$
RR-COVER TAPE MOD	Cover Tape Module		\$	\$
RR-ROBOT I/O COMM	Robot I/O Board Module		\$	\$
RR-FIBER OPTIC CA	Amplifier Fiber Cable Assembly		\$	\$
RR-SMT COMM PORT	Communications PCB		\$	\$
RR-PNEUMATIC MODULE	Pneumatic Module		\$	\$
RR-DIAGNOSTICS BOARD	Diagnostics Adapter Board (DAB)		\$	\$
PROGRAMMER ALIGNMENT TOOL	Programmer Alignment Tool		\$	\$

Signature: _____ Date: _____ Company: _____

P

The Self-Service Spares Kit for Microcontroller RoadRunner (RR-MICRO-SELFSV SPARES KIT-P) contains parts listed on [page P-56](#). It is available to those who have attended an Advanced RoadRunner Service course.

Customer Training

For information about advanced training, contact the Data I/O Customer Service Center. A training course may be ordered when purchasing a RoadRunner or at a later time.

NOTE: This manual does not list replacement instructions for all the parts in the Self-Service Spares Kit. For additional information, contact Data I/O or your nearest authorized representative. To find your nearest representative, see the instructions on the last page of this manual.

Socket Adapter, Actuator, and Precisor



Figure P-49—Precisor, Actuator, and Socket Adapter Locations

A precisor is a plate that assists in aligning devices on the probes before they are placed into the programming sockets.

The Actuator Plate opens the sockets on the Socket Adapter (assisted by air cylinders).

The Socket Adapter is the interface between the specific device and the programmer. Socket manufacturers' specifications are used for expected socket life.

Since these three parts—Precisor Plate, Actuator Plate and Socket Adapter—are determined by the device package, they may need to be replaced for each new device type you wish to program. Call Data I/O Customer Service, or contact your nearest authorized Data I/O representative, for parts or device programming kits. Contact information are on the last page of this manual.

See the ProLINE-RoadRunner *Owner's Manual* for the following:

- To remove the **Precisor** see “Changing the Precisor” in Chapter 3.
- To remove the **Actuator Plate** see “Changing the Actuator Plate” in Chapter 3.
- To remove the **Socket Adapter** see “Changing the Socket Adapter” in Chapter 3.

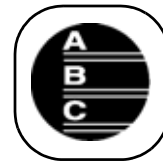

Index

A

- Adjustable Tape-In Module
 - aligning P-10
 - removing P-9
- Air Filters
 - description P-14
 - ordering P-14
 - replacing P-15
- Air Paths, keeping clean P-14

B

- Basic Spares Kit
 - Memory P-50
 - Microcontroller P-54
 - ordering P-50, P-54
- Broken tape sensor P-12

C

- Communications Cable
 - removing P-23
- Communications Cable, removing P-23
- Components, listed P-2
- Contact Information. See inside back cover.
- Control Panel Module
 - ordering P-30
 - removing P-31
- Conveyor Belt Cover, removing P-6

- Conveyor Dust Cover, removing P-6
- Conveyor Module P-22, P-26, P-52, P-56
 - drop height P-24
 - reinstalling P-24
 - removing P-24
- Cover Tape Module
 - ordering P-20
 - removing P-21
- Cover Tape-broken sensor P-12
- Covers, ordering P-4
- Customer Training P-53, P-57

D

- Delay Times, resetting P-35

E

- Electrostatic Discharge iii
- End-of-Belt Sensor
 - adjusting P-25
 - reteaching P-25
 - testing P-25
- ESD. See Electrostatic Discharge

F

- Front Cover, removing P-5

G

Grounding iii

I

I/O Board P-52, P-56
Interconnect Panel P-42
Interface Manifold P-34

P

Pick and Place Head
 aligning P-33
 ordering P-38
 removing P-38 to P-39
Pick and Place Head Cover, removing P-5
Pick delay time P-35
Pick Sensor. See End-of-Belt Sensor
Pneumatic Module
 adjusting. See Probe, vacuum sensor.
 reinstalling P-18
 removing P-16

"I don't see Jabberwocky in here. It should be here."

Let us know about the items you can't find by e-mailing:
userdocs@dataio.com.

L

Lower Cover, removing P-5

M

Manifold, pneumatic P-14
Modules
 pictured P-2
 replaceable P-1
Motion Controller PCB P-3

Probe

 balancing speed P-33
 speed specification P-34
 speed, adjusting P-33
 vacuum sensor, adjusting P-36
Probe Tip, replacing P-51, P-55
Programmer Module
 alignment P-44
 alignment tool P-43
 description P-40
 reinstalling P-43
 removing P-41
Puff duration P-35

O

Order Form
 Basic Spares Kit/parts P-50, P-54
 Control Panel Module P-30
 Conveyor Belt Module P-22
 Cover Tape Module P-20
 Covers P-4
 Linear Stage Module P-46
 Pneumatic Module P-14
 PNP head P-38
 Programmer Module P-40
 Reject Bin P-28
 Self-Service Spares Kit/parts P-52, P-56
 Tape-In Module P-8
 Vacuum Filters P-14
Overview of Components P-2

R

Reject Bin
 bracket P-29
 full sensor P-28
 sensor removal P-29
Robot I/O Board P-52, P-56

S

Safety
 grounding iii
 precautions iii
Self-Service Spares Kit
 Memory, locations P-52
 Microcontroller, locations P-56

- ordering parts P-52, P-56
- Serial Number, location P-3
- Service
 - component overview (figure) P-2
 - replacing assemblies P-1
- Socket Adapter, wear P-40
- Spare parts P-52, P-56
 - Memory, locating P-50
 - Microcontroller, locating P-54
 - ordering P-50, P-54
- Standard Tape-In Module. See Tape-In Module.

T

- Tape-In Module
 - aligning P-12
 - jamming P-8
 - ordering parts P-8
 - removing P-11
- Tape-In Module. Also see Adjustable Tape-In Module.
- Throughput P-33
- Training P-53, P-57
- Travel* delay time P-35
- Tube fittings P-16

U

- Communications Cable P-22

V

- Vacuum Sensor (Probe), adjusting P-36

W

- Warning
 - electrical shock P-5

Sales and Technical Support

World Wide

Data I/O Corporation
6464 185th Avenue N.E., Suite 101
Redmond, WA USA 98052



Telephone: 425-881-6444
 inside US 1-800-332-8246
Fax: 425-867-6972
E-mail: support@dataio.com

Contact Data I/O World Wide Support or your local representative. To find your local representative on our Web site, go to <http://www.dataio.com> and click **Contact Us** (upper right), then click **Representative Search** (left side). Then follow the instructions.



When calling or writing, please provide the following information:

- RoadRunner Serial number
- Software Version displayed on the keyboard screen at start-up (turn the power off and then on again)
- Detailed description of the problem you are experiencing (if any)
- Error messages (if any)
- Device manufacturer, part number, package style and number of pins (if device-related)
- Name, telephone number and address